

# Sonnar® T\* 4/150 CFi

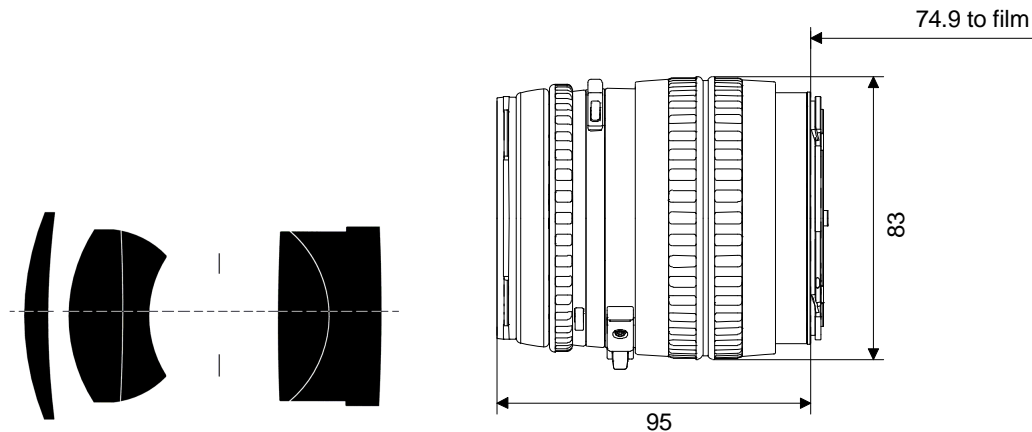

H A S S E L B L A D

The Sonnar® T\* 4/150 CFi lens has been the classical portrait lens in the Hasselblad system. With a focal length approximately twice the image frame diagonal the Sonnar® T\* 4/150 CFi lens delivers the ideal perspective for classic head and shoulder portraits. The built-in Prontor shutter allows for flash synchronisation up to 1/500 s providing the photographer with the freedom to balance flash and ambient light very creatively.

The Sonnar® T\* 4/150 CFi lens is very compact and, together with a Hasselblad camera body, it makes for a unit that can be easily used for handheld photography. On the other hand the Sonnar® T\* 4/150 CFi lens offers an optical performance so high, that its sharpness can be fully exploited only with a very good tripod.

**Preferred use:** portraits of all kinds, fashion, scenic landscapes

<b>Cat. No. of lens</b>	<b>10 11 36 - 9901</b>		
Number of elements	5	Close limit field size	389 mm x 389 mm
Number of groups	3	Max. scale	1 : 7.1
Max. aperture	f/4	Entrance pupil*	
Focal length	151.5 mm	Position	67.4 mm behind the first lens vertex
Negative size	55 x 55 mm	Diameter	37.8 mm
Angular field 2w*	width 21°, height 21°, diagonal 29°	Exit pupil*	
Min. aperture	32	Position	30.2 mm in front of the last lens vertex
Camera mount	CFi	Diameter	27.7 mm
Shutter	Prontor CFi	Position of principal planes*	
Filter connection	bayonet series 60	H	11.7 mm behind the first lens vertex
Focussing range	infinity to 1.4 m	H'	70.9 mm in front of the last lens vertex
Working distance (between mechanical front end of lens and subject)	1.2 m	Back focal distance	80.5 mm
		Distance between first and last lens vertex	83.4 mm
		Weight	850 g

\*at infinity



Performance data:

**Sonnar® T\* 4/150 CFi**  
 Cat. No. 10 11 36 - 9901

**1. MTF Diagrams**

The image height  $u$  - calculated from the image center - is entered in mm on the horizontal axis of the graph. The modulation transfer  $T$  (MTF = Modulation Transfer Factor) is entered on the vertical axis. Parameters of the graph are the spatial frequencies  $R$  in cycles (line pairs) per mm given at the top of this page.

The lowest spatial frequency corresponds to the upper pair of curves, the highest spatial frequency to the lower pair. Above each graph, the f-number  $k$  is given for which the measurement was made. "White" light means that the measurement was made with a subject illumination having the approximate spectral distribution of daylight.

Unless otherwise indicated, the performance data refer to large object distances, for which normal photographic lenses are primarily used.

**2. Relative illuminance**

In this diagram the horizontal axis gives the image height  $u$  in mm and the vertical axis the relative illuminance  $E$ , both for full aperture and a moderately stopped-down lens. The values for  $E$  are determined taking into account vignetting and natural light decrease.

**3. Distortion**

Here again the image height  $u$  is entered on the horizontal axis in mm. The vertical axis gives the distortion  $V$  in % of the relevant image height. A positive value for  $V$  means that the actual image point is further from the image center than with perfectly distortion-free imaging (pincushion distortion); a negative  $V$  indicates barrel distortion.

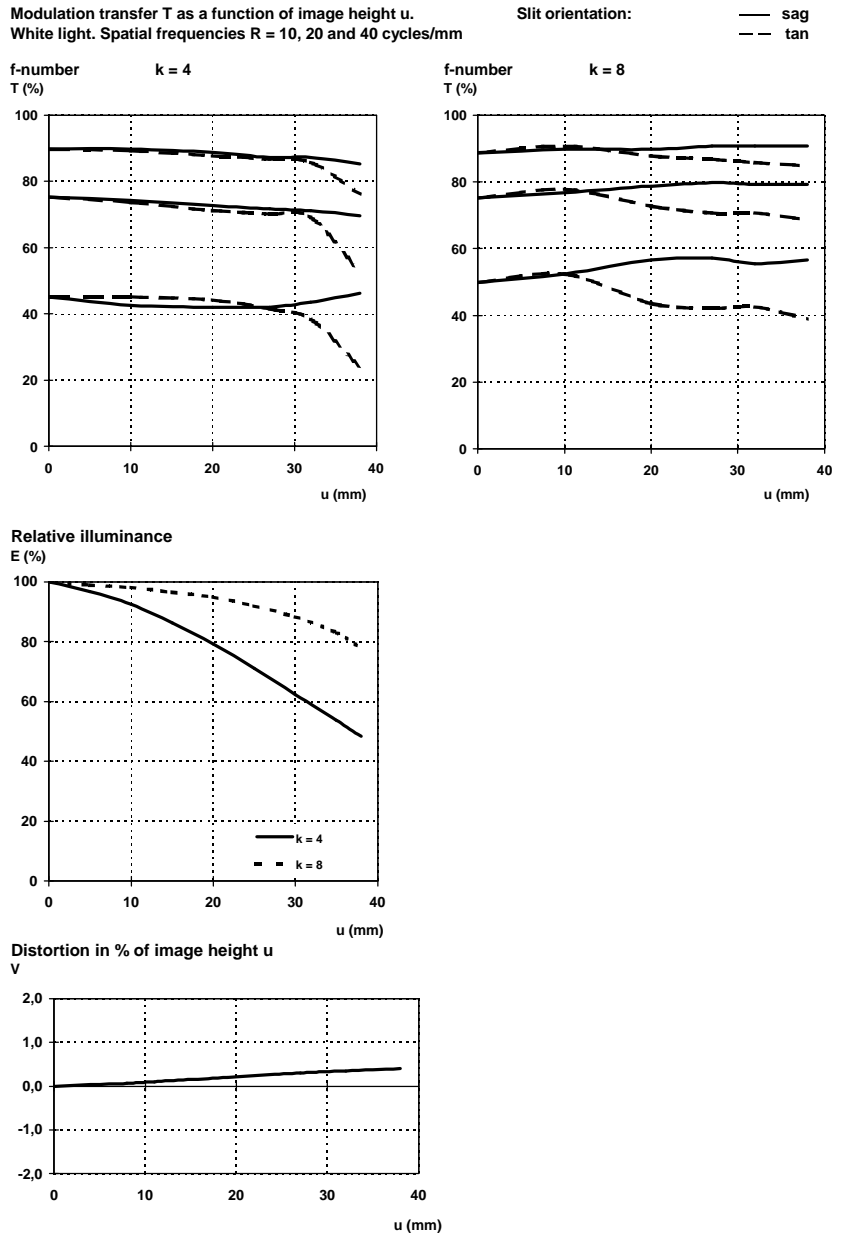

Subject to change.  
 Printed in Germany 20.06.2002



**Carl Zeiss**  
 Camera Lens Division  
 73446 Oberkochen  
 Germany  
 Telephone ++49-7364-20-6175  
 Fax ++49-7364-20-4045  
 eMail: photo@zeiss.de  
 http://www.zeiss.de/photo