

Sonnar T*
f/2.8–150 mm
Cat. No. 101085

H A S S E L B L A D



ZEISS

Carl Zeiss
D-7082 Oberkochen
West Germany

The **Sonnar T*** f/2.8–150 mm lens is a fast high-performance lens of medium focal length for the Hasselblad 2000 FC with focal-plane shutter.

If, at a relatively high speed, the focal length is to be twice or three times as long as the diagonal of the film format, this type of lens is especially suited for achieving a high imaging performance. Zeiss were the first to come up with lenses of this type and have given priority to their further development. The **Sonnar T*** f/2.8–150 mm lens fully utilizes the potential of extremely good and balanced correction inherent in this lens type.

Apart from the high imaging performance this lens is distinguished by further features which are important for single-lens reflex cameras in particular: at infinity setting the distance of the exit pupil from the film

is by 30% shorter than the focal length. This ensures that rays leaving the lens are not vignetted anywhere in the space between optics, film and image corners and that the finder area is fully illuminated. At infinity setting, the distance of the front lens vertex from the film plane is only as long as the focal length which permits a remarkably compact lens design.

The **Sonnar T*** f/2.8–150 mm lens is a first-class lens of extraordinary versatility. It is suited for sports and portrait photography and allows – thanks to its relatively high speed – hand-held exposures under unfavourable lighting conditions. In portrait photography this lens guarantees a correct perspective and permits the elimination of unsteady and thus disturbing background by using full aperture.

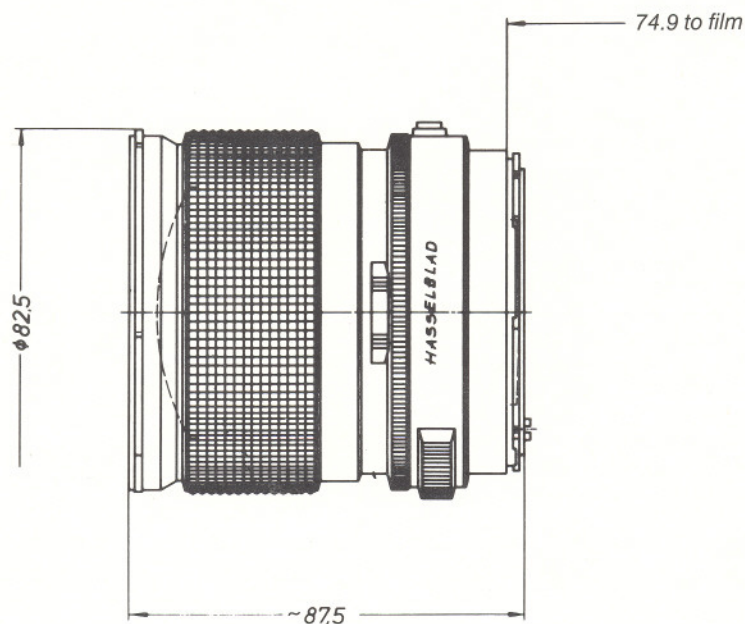

Number of lens elements: 5
 Number of components: 4
 f-number: 2.8
 Focal length: 151.1 mm
 Negative size: 56.5 x 56.5 mm
 Angular field 2 w: diagonal 29.5°, side 21°
 Spectral range: visible spectrum
 f-stop scale: 2.8–4–5.6–8–11–16–22
 Mount: focusing mount with bayonet; coupling system for automatic diaphragm function
 Filter mount: bayonet, size B 77
 Weight: approx. 680 g

Distance range: ∞ to 1.4 m (4.5 ft)
 Smallest object field: 400 mm x 400 mm (15.8" x 15.8")
 Position of entrance pupil: 58.9 mm behind the first lens vertex
 Diameter of entrance pupil: 52.5 mm
 Position of exit pupil: 37.1 mm in front of the last lens vertex
 Diameter of exit pupil: 38.2 mm
 Position of principal plane H: 0.8 mm in front of the first lens vertex
 Position of principal plane H': 79.7 mm in front of the last lens vertex
 Distance between first and last lens vertex: 80.1 mm

Modulation transfer T as a function of image height u

Slit orientation tangential ———
sagittal ———

White light

Spatial frequencies R = 10, 20 and 40 cycles/mm

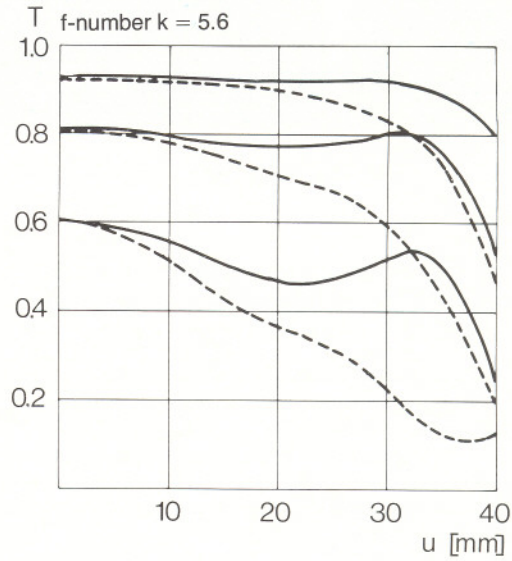
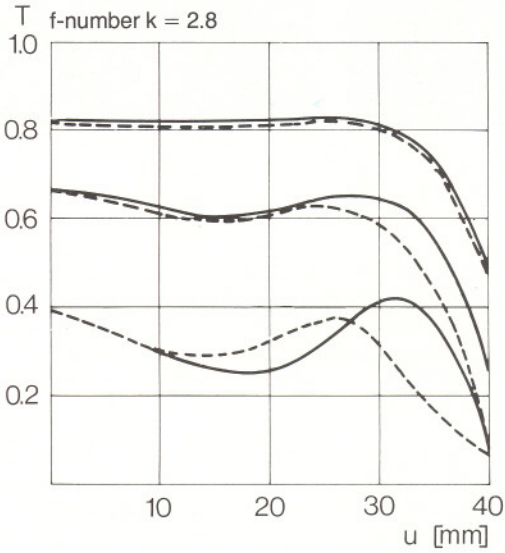

1. MTF Diagrams

The image height u – reckoned from the image center – is entered in mm on the horizontal axis of the graph. The modulation transfer T (MTF = **M**odulation **T**ransfer **F**actor) is entered on the vertical axis. Parameters of the graph are the spatial frequencies R in cycles (line pairs) per mm given at the top right hand above the diagrams.

The lowest spatial frequency corresponds to the upper pair of curves, the highest spatial frequency to the lower pair. Above each graph the f-number k is given for which the measurement was made. "White" light means that the measurement was made with a subject illumination having the approximate spectral distribution of daylight.

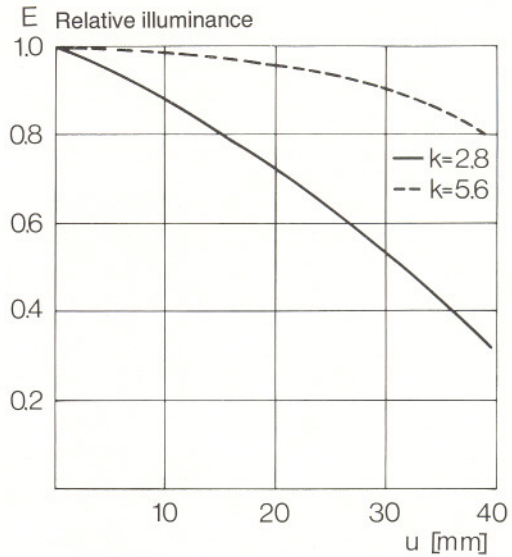

Unless otherwise indicated, the performance data refer to large object distances, for which normal photographic lenses are primarily used.

2. Relative illuminance

In this diagram the horizontal axis gives the image height u in mm and the vertical axis the relative illuminance E, both for full aperture and a moderately stopped-down lens. The values for E are determined taking into account vignetting and natural light decrease.

3. Distortion

Here again the image height u is entered on the horizontal axis in mm. The vertical axis gives the distortion V in % of the relevant image height. A positive value for V means that the actual image point is further from the image center than with perfectly distortion-free imaging (pincushion distortion); a negative V indicates barrel distortion.

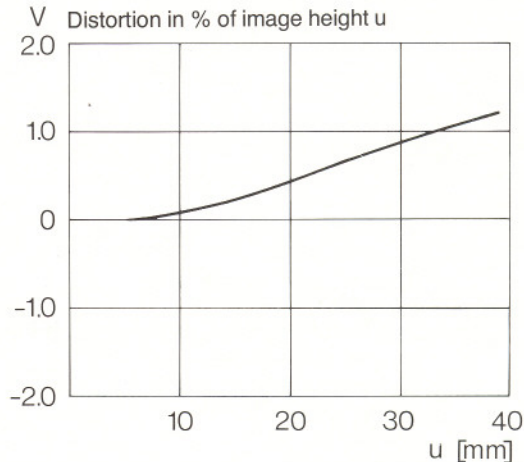

Subject to technical amendment