

Planar T*
f/2.8–80 mm
Cat.-No. 102076

H A S S E L B L A D



ZEISS

Carl Zeiss
D-7082 Oberkochen
West Germany

This Planar lens is characterized by an extremely uniform edge-to-edge sharpness at full aperture, owing to the excellent correction of all lens aberrations. As indicated by its name, the anastigmatic flatness of the image field is outstanding.

Apart from the Planar f/3.5–100 mm this lens is standard outfit of the Hasselblad 500 C and 500 EL cameras.

The lens is suited for almost any task in general photography.

The focal length corresponds approximately to the diagonal of the 6 x 6 cm format.

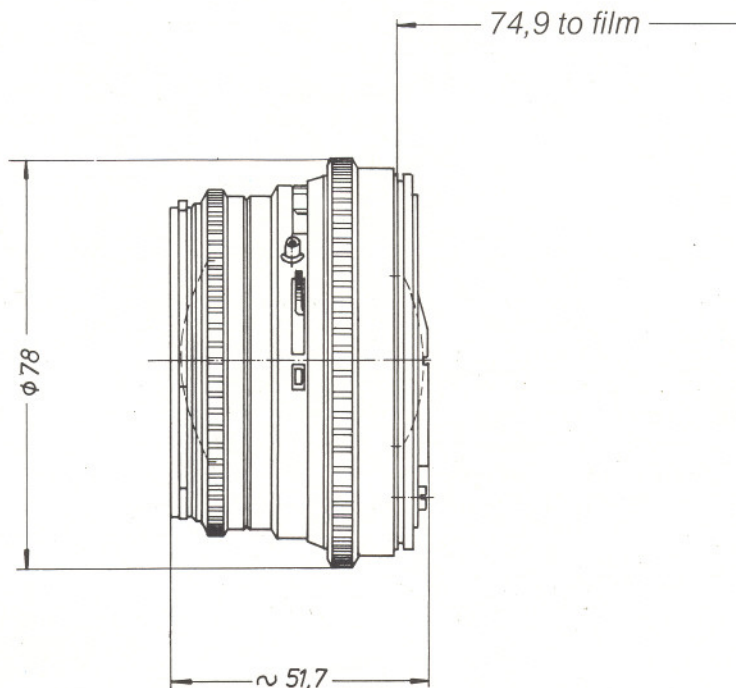

Number of lens elements: 7
 Number of components: 5
 f-number: 2.8
 Focal length: 80.5 mm
 Negative size: 56.5 x 56.5 mm
 Angular field 2 w: diagonal 52°, side 38°
 Spectral range: visible spectrum
 f-stop scale: 2.8 - 4 - 5.6 - 8 - 11 - 16 - 22
 Mount: Compur interchangeable reflex shutter size 0 with automatic iris diaphragm bayonet for Hasselblad series 50
 Filter mounting:
 Weight: 465 g

Distance range: ∞ to 0.9 m
 Automatic depth-of-field indication for $z = 0.06$ mm *)
 Position of entrance pupil: 26.6 mm behind the first lens vertex
 Diameter of entrance pupil: 28.8 mm
 Position of exit pupil: 25.7 mm in front of the last lens vertex
 Diameter of exit pupil: 34.5 mm
 Position of principal plane H: 39.0 mm behind the first lens vertex
 Position of principal plane H': 10.8 mm in front of the last lens vertex
 Distance between first and last lens vertex: 46.4 mm
 *) z = circle-of-confusion diameter

Modulation transfer T as a function of image height u

Slit orientation tangential — — — —
sagittal —————

White light

Spatial frequencies R = 10, 20 and 40 cycles/mm

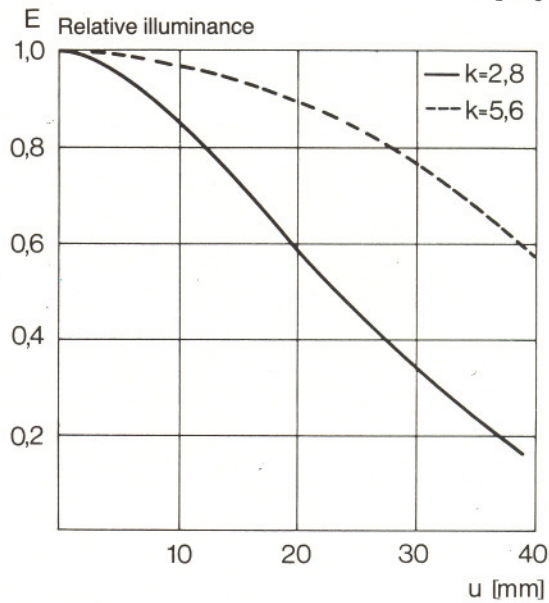
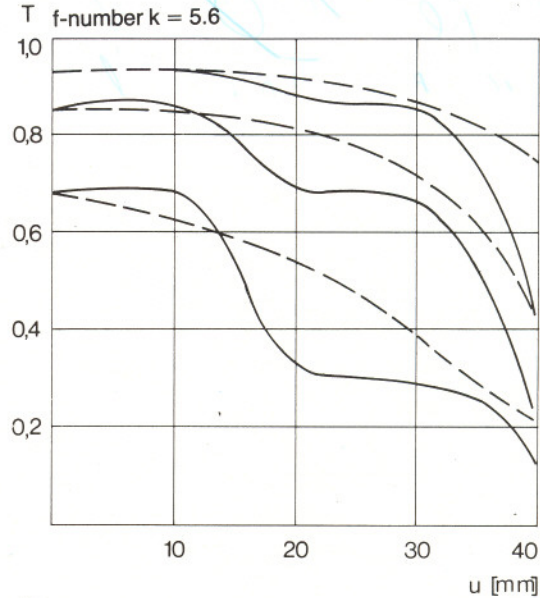
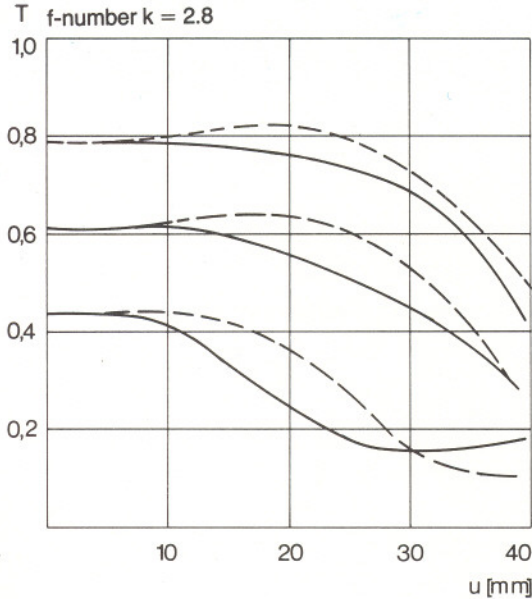

1. MTF Diagrams

The image height u – reckoned from the image center – is entered in mm on the horizontal axis of the graph. The modulation transfer T (MTF = Modulation Transfer Factor) is entered on the vertical axis. Parameters of the graph are the spatial frequencies R in cycles (line pairs) per mm given at the top right hand above the diagrams. The lowest spatial frequency corresponds to the upper pair of curves, the highest spatial frequency to the lower pair. Above each graph the f-number k is given for which the measurement was made. "White" light means that the measurement was made with a subject illumination having the approximate spectral distribution of daylight.

Unless otherwise indicated, the performance data refer to large object distances, for which normal photographic lenses are primarily used.

2. Relative illuminance

In this diagram the horizontal axis gives the image height u in mm and the vertical axis the relative illuminance E , both for full aperture and a moderately stopped-down lens. The values for E are determined taking into account vignetting and natural light decrease.

3. Distortion

Here again the image height u is entered on the horizontal axis in mm. The vertical axis gives the distortion V in % of the relevant image height. A positive value for V means that the actual image point is further from the image center than with perfectly distortion-free imaging (pincushion distortion); a negative V indicates barrel distortion.

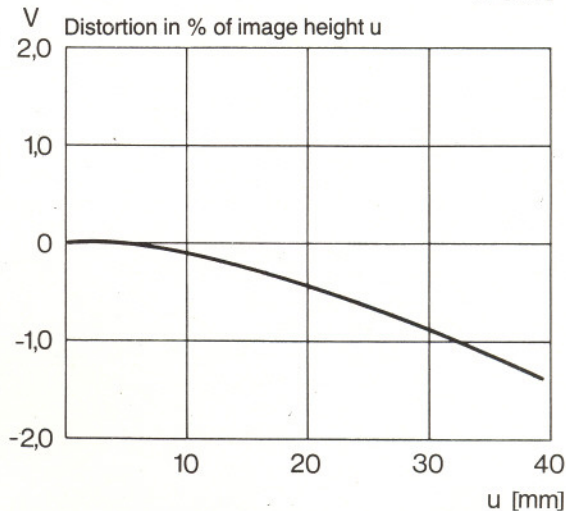

Subject to technical amendment