

Zeuxa
BRONICA
BELLOWS ATTACHMENT

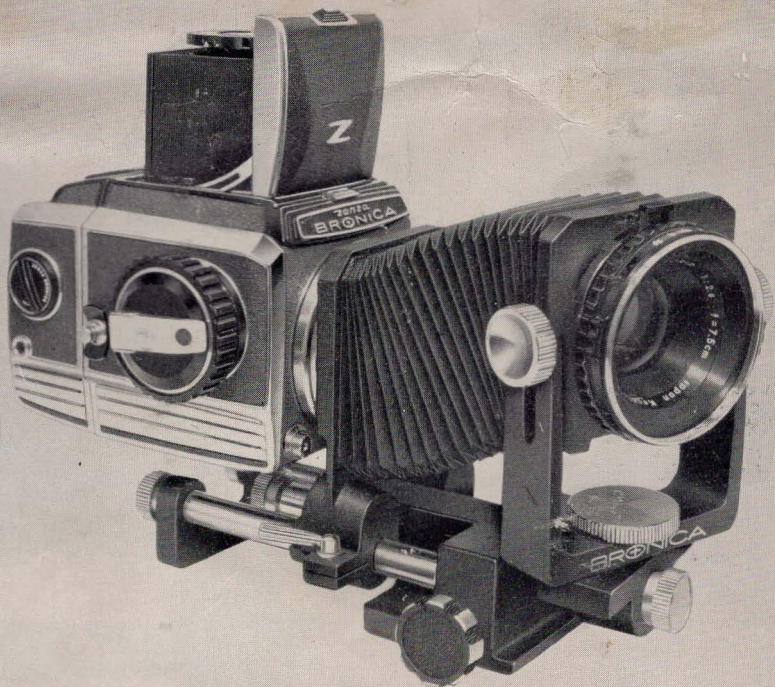

BRONICA BELLOWS ATTACHMENT

The Bronica Bellows Attachment, inserted between the camera body and the lens, allows extending the lens-to-film distance continuously, so as to take macro, micro, close-up and copy photographs. A wide range of unusual photography can be enjoyed with this attachment, which fits either the Zenza Bronica or the Zenza Bronica-S.

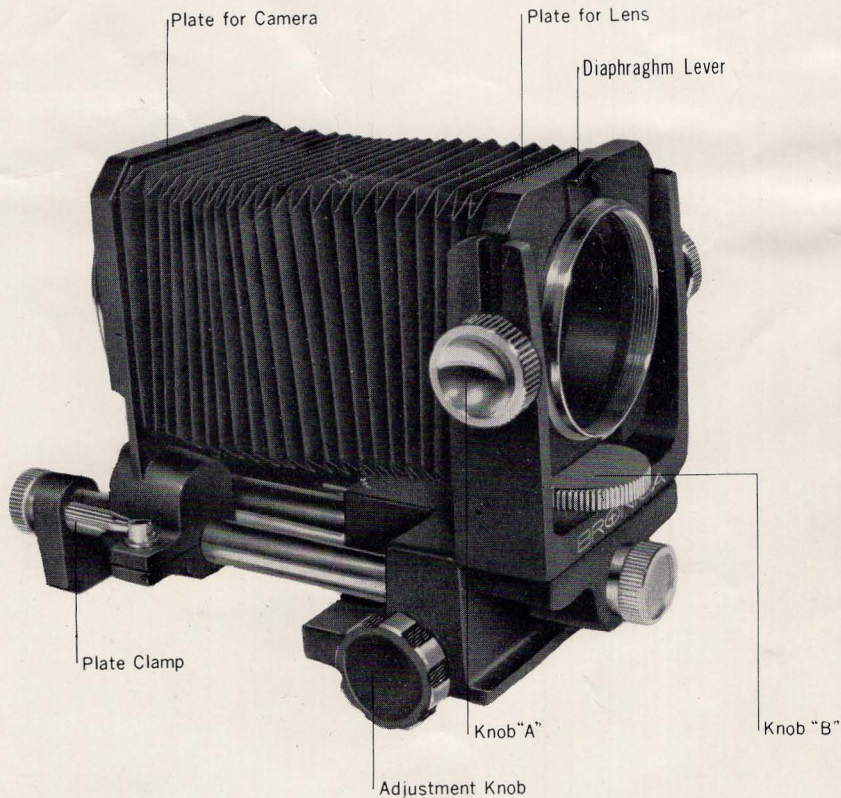

Lens Reversing for Close-ups

A standard lens, if used for extreme close-up pictures, may give a curved image and sometimes an out-of-focus image of the complete picture. Good results can be obtained in such cases by reversing the lens and using the lens reversing ring and tube "A"

First remove the lens from the Bellows Attachment and screw the lens reversing ring into the Bellows Attachment; then screw in the reversed lens. Next attach tube "A" to the rear of the lens. (Without tube "A", the aperture of the reversed lens is always wide open.)

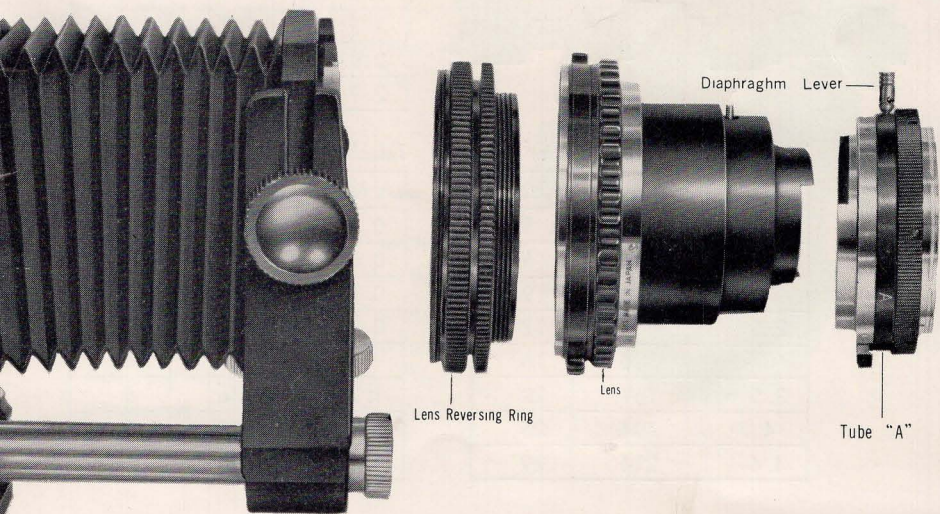

Magnification and Exposure Increase Rate

The following lists show the relation between the length of the Bellows and the photographic magnification obtained. The actual size of the image on the ground glass can be measured by removing the viewfinder hood.

For extreme close-up pictures, more exposure time is necessary than for ordinary photography (i.e. more than what the exposure meter indicates). This proportion is called the Exposure Increase Rate.

Suppose we call the degree of magnification "M" then

$$\text{Exposure Increase Rate} = (1 + M)^2$$

For example, a 1× (i.e., life size) magnification with the normal lens involves a 71mm bellows extension, and a 4× increase in exposure.

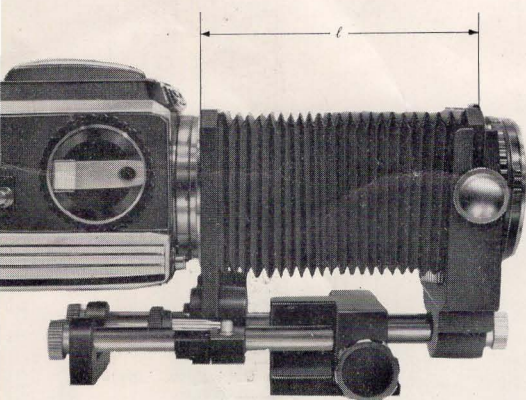

Standard Lens $f=75\text{mm}$ $f/2.8$

M	Length(m/m)	E.I.R.
0.9×	63.2	3.6×
1	71	4
1.2	87	5
1.5	110	6
1.8	133	8
2	148	9
2.2	164	10
2.5	187	12
2.8	210	14
2.9	214	15

Wide Angle Lens $f=50\text{mm}$ $f/3.5$

M	Length(m/m)	E.I.R.
1.3×	60	5×
1.5	69	6
2	94	9
2.5	119	12
3	144	16
3.5	169	20
4	194	25
4.4	214	29

Telephoto Lens $f=135\text{mm}$ $f/3.5$

M	Length(m/m)	E.I.R.
0.5×	60	2.3×
0.6	75	2.6
0.7	88	2.9
0.8	102	3
1	129	4
1.2	156	5
1.4	183	6
1.6	210	7

How to Attach Bellows to Camera

Loosen the plate clamp and fully extend the Bellows. Align the red dot on the mounting ring of the Bellows and the red dot on the camera body and turn the camera body clockwise 1/8th turn. Use the same method of aligning the red dots for attaching the lens to the Bellows.

To remove the lens, depress the lens lock button on the lens and turn the lens counterclockwise. To remove the Bellows, depress the Bellows lock button and turn the Bellows counter-clockwise.

Focusing Adjustment

Loosen the plate clamp on the Bellows and adjust the focus by moving the plate. Tighten the clamp at the selected position. Turn the adjustment knob for finer focus.

Opening of Diaphragm for Viewing

Move the diaphragm lever to the left. The diaphragm aperture will then be wide open for viewing. After viewing, move the lever to the right. The diaphragm aperture will close down to the aperture opening preselected.

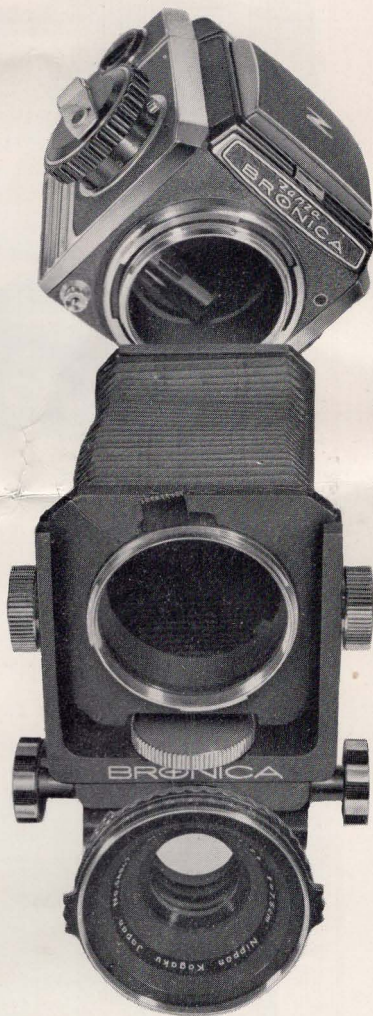

Changing the Light Axis of the Lens

By changing the light axis of the lens ("swings and tilts") the normal condition between the surface of the film and the light axis of the lens is altered in order to obtain various corrections and special effects.

Correction up: Loosen the knobs "A" and lift the lens to the desired position selected in the viewfinder. Tighten the knobs to lock in position.

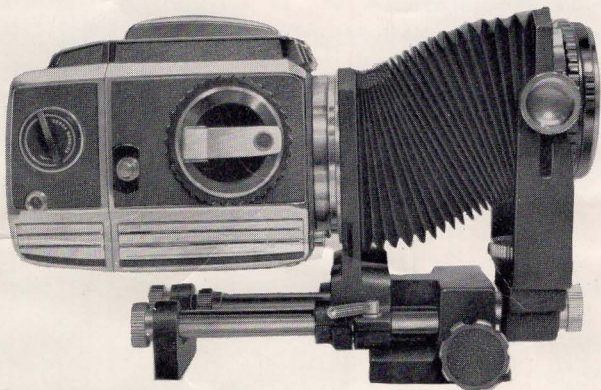

Right or Left: Loosen the knob "B" and rotate the lens to the right or left, to the desired position selected in the viewfinder. Tighten the knob to lock in position.

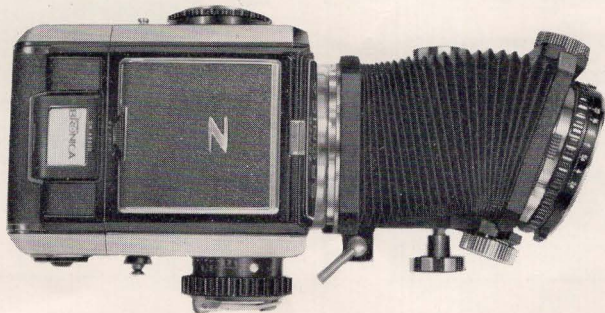

Mechanical Back

The following are the shortest and longest dimensions obtainable with the Bellows attached to the Zenza Bronica or the Zenza Bronica-S.

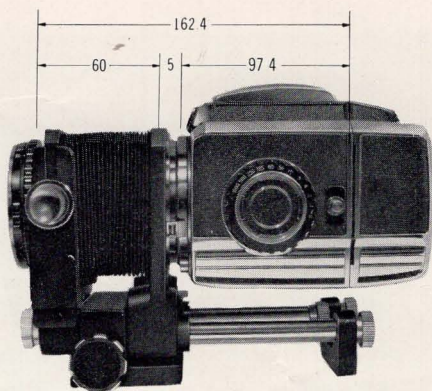

Film Surface

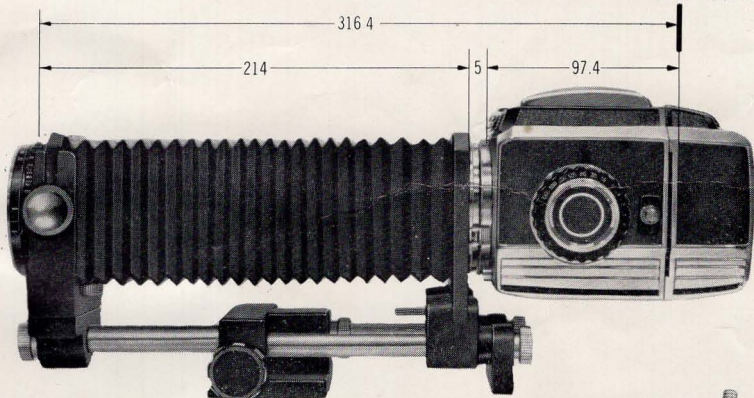

Extension Tube Set

This provides semi-automatic diaphragm control when used with Automatic Nikkor lenses, and consists of four extension tubes: one A-tube, one B-tube, and two C-tubes.

The A-tube may be used independently, or together with the B-tube.

C-tubes further increase the extension, but must be used in connection with both an A-tube and a B-tube.

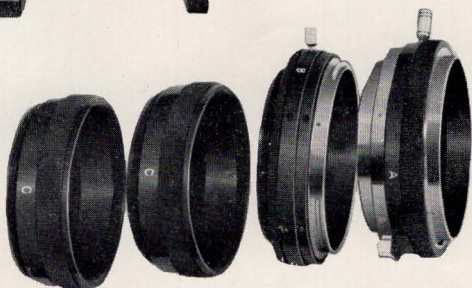

The reproduction ratio is determined by the focal length of the lens being used and by the combination of extension tubes.

- ▶ The Bellows Attachment can be fastened to a tripod or to copying stands by using the interior screw thread provided beneath the attachment plate
- ▶ For even greater magnification, the Bronica Extension Tubes can be added to the Bellows.
- ▶ For close-up pictures with the Bronica-S, the mirror lock-down button may be used to completely eliminate mirror shock.
- ▶ If lenses of studio or other large cameras are used on the Bronica, the Bellows Attachment may be utilized to achieve the proper lens distance.

Bellows lens mount screw thread is:

57m/m diameter \times 1m/m pitch.

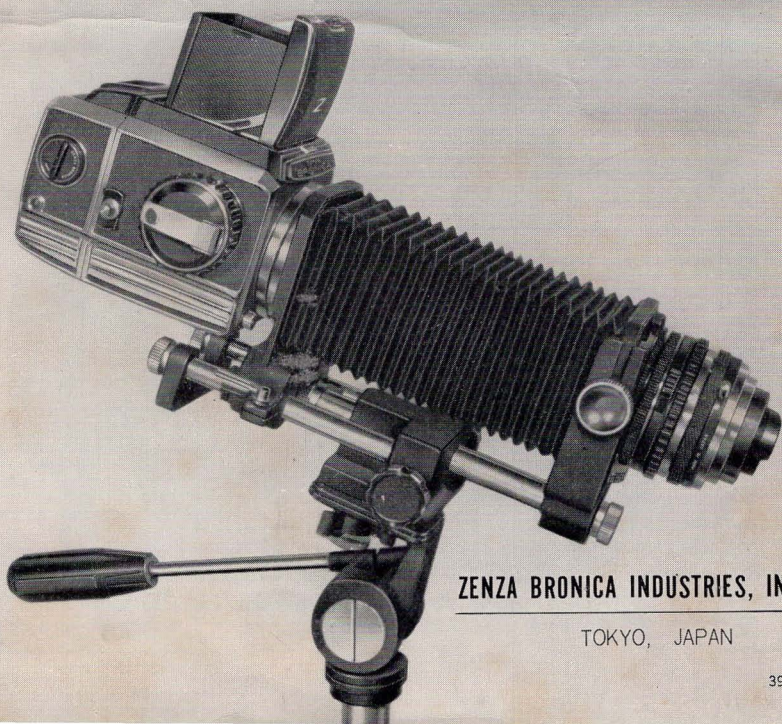

ZENZA BRONICA INDUSTRIES, INC.

TOKYO, JAPAN