



Zenza
BRONICA Model **C**

2 1/4-square single-lens reflex

**Features
of the
Zenza Bronica Model C
& Instructions**

**ZENZA BRONICA INDUSTRIES, INC.
Tokyo, Japan.**



lenza
BRONICA

Contents

Special features	3
Nomenclature	4-5
Film loading	6-8
Removing exposed film	8
Taking photographs	9-10
Shutter	11
Cable release	12
Shutter speed device	12
Safety lock	13
Flash	13
Bronica neck strap	13
Multiple exposure device	14
Interchanging lenses	15
Nikkor interchangeable lenses	16
Using Helicoid	17
Close-up photographs	18-19
Focusing hood	20
Filters	21
Specifications	24



SPECIAL FEATURES FOR THE ZENZA BRONICA MODEL - C CAMERA

The Zenza Bronica Model - C Camera is a sister camera to the S type, which is the supreme single lens reflex camera of 6×6 size.

This camera has the efficiency of the S type, and is mechanically improved. The shutter sound and mirror shock are reduced as the result of experience with the S type, and constant research over a long period.

■ Instant Return Automatic Mirror:

The reflex mirror of Bronica Model - C is an exclusive and original mechanism. It is very different from that of other single lens reflex cameras. Usually mirrors move upward, but the Bronica instant return automatic mirror moves forward and down. After the exposure, it instantly and automatically returns to viewing position.

Thus, it is possible to use wide-angle and large caliber lenses, and a bright image remains on the ground glass except while the shutter is in motion.

■ Exclusive Nikkor Lenses and Automatic Diaphragm:

Nikkor lenses are especially designed for Bronica Cameras and can be used on both C type and S type. You can speedily adjust the focus of the

bright image; These lenses (50mm, 75mm, 135mm and 200mm) have an instant reopening automatic diaphragm.

■ Depth - of - Field Preview Button:

By pressing this depth - of - field preview button, you can check the depth-of-field before exposing.

■ Multiple Exposure Device:

This is a special mechanism you can easily use for commercial or artistic photo techniques.

■ Switch Lever for 24 Exposures:

Ordinary 120 film gives 12 exposures. 24 exposures are possible on the 220 the new size film. The Bronica Model - C has an entirely new system permitting either length to be used.

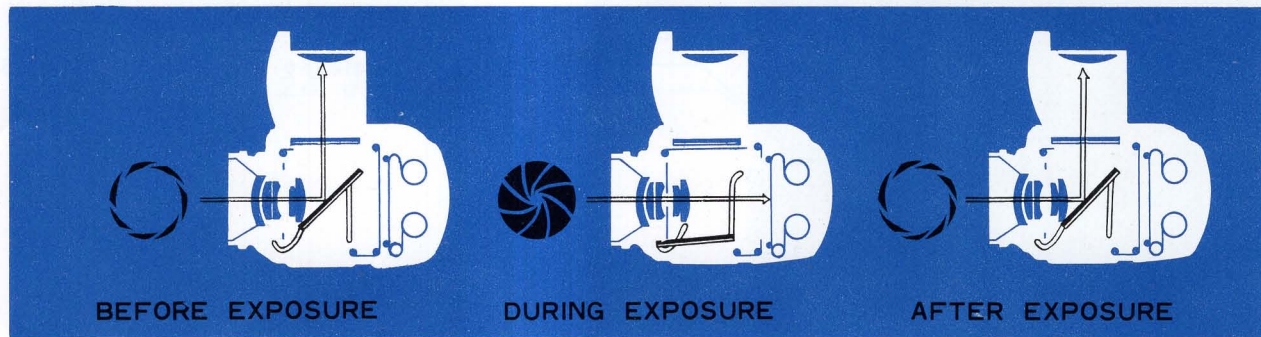

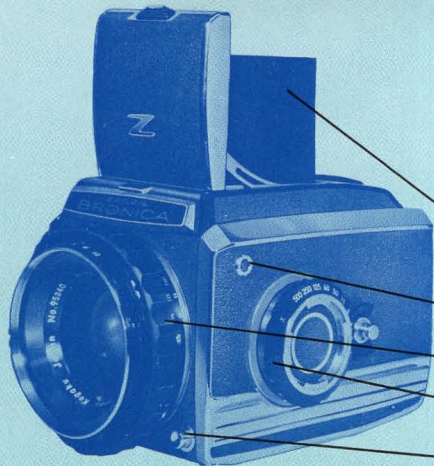

Focusing hood

Synchro terminal

Helicoid (Focusing adjusting ring)

Shutter dial

Depth-of-field preview button

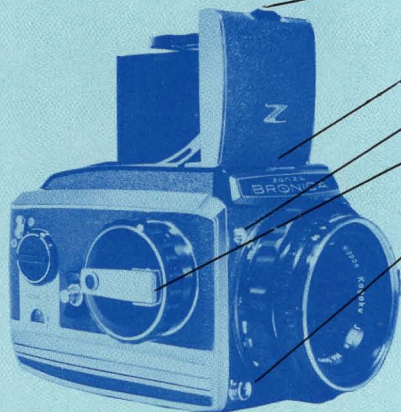

Focusing hood lock

Focusing hood retaining lock

Helicoid retaining lock

Film winding knob

Shutter release with cable release socket

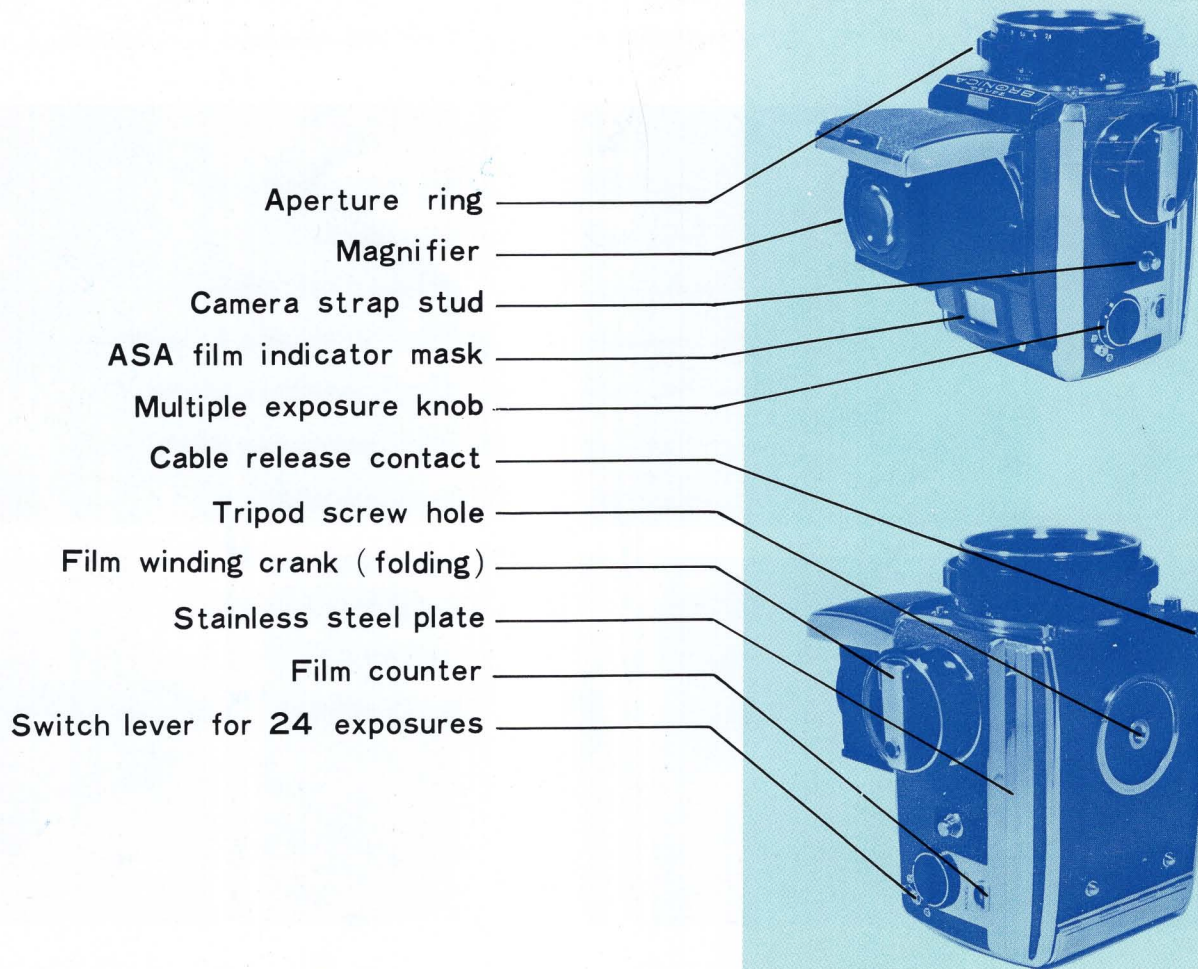

FILM LOADING

The ZENZA BRONICA-C use 120 and 220 (Brownie) size roll films

1. Lift Film Indicator Mask and Press hood lock to right. Back will spring open.



2. Remove Film holder. (Press two knobs shown)



3. Insert Take-up Spool and Fresh Film spool



4. Draw Leader pater across pressure plate

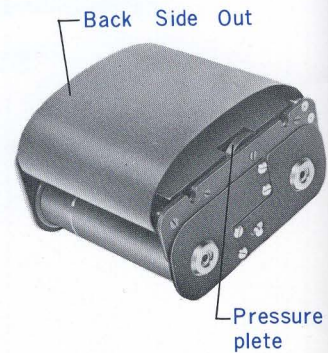

Avoid direct light on film while loading

5. Insert paper end in
Take-up spool.

6. Replace Film holder
in camera. Nipple "B"
will fit in hole of stud
"A"

7. Before closing back,
Turn film forward so
that film start mark
matches Red dot on
holder

8. Close back

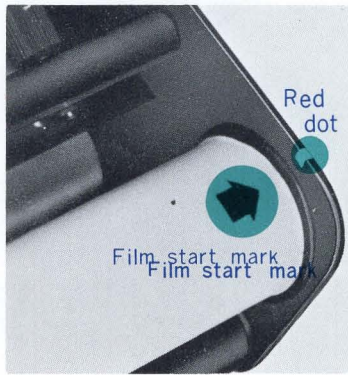
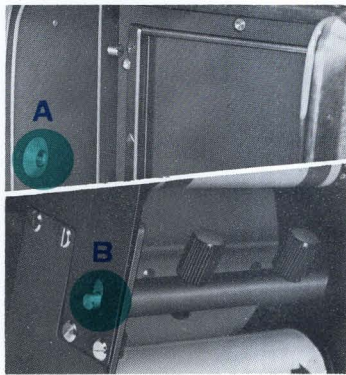
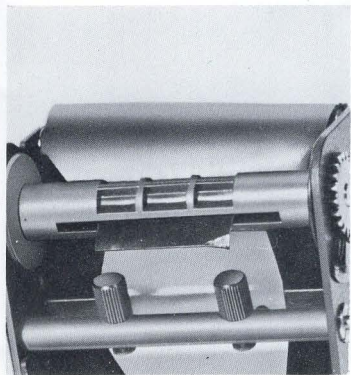

REMOVING EXPOSED FILM

9. As a reminder of what type of film has been loaded, Put an end of the film box in the indicator mask.

10. The number of the next exposure is shown in the film counter window. After #8, even numbers only are shown; Odd numbers are indicated by a line.

1. After taking last exposure, wind forward until film counter window does not move.

2. Open back cover remove film holder by pressing knobs together. And pulling out gently.

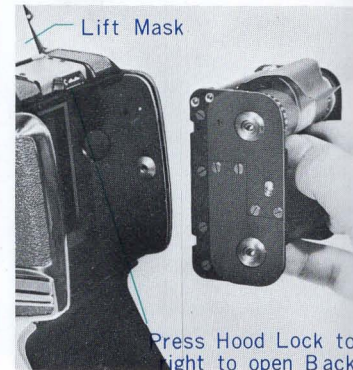
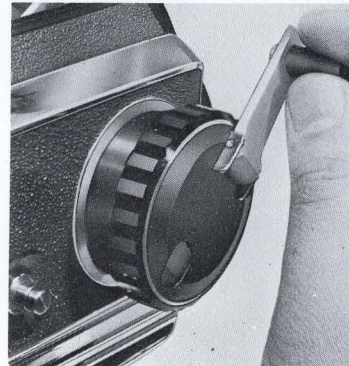

TAKING PHOTOGRAPHS

1. To cock shutter and advance film, wind clockwise as shown below.

2. Turn desired aperture ("Stop") to white dot, (Intermediate apertures may be used, between the "Click" stops.)

3. To open focusing hood, slide hood lock to right. To close, press down sides, then back, then the cover.

4. Magnifier rises when cover is pressed toward cover. Press magnifier back into place before closing hood.

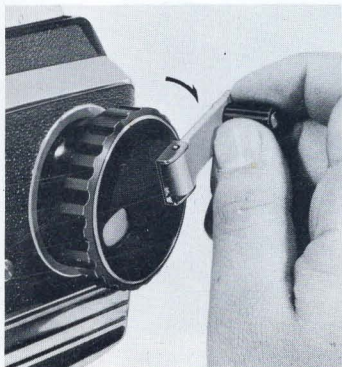

5. Observing image on ground glass, focus by rotating helicoid as shown.

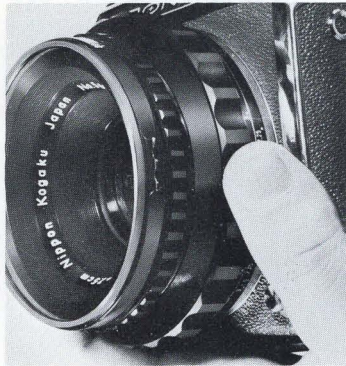

6. Focusing scales for standard 75mm lens and telephoto 200mm lens are shown in white. Telephoto 135mm and Wideangle 50mm are shown in red. Four red dots to right of infinity mark (∞) show the infinity points, when using infra-red film.



7. Depth of field scale for all lenses is shown below. Line between f8 and f4 represents f5.6. Also shown is the preview button which permits.

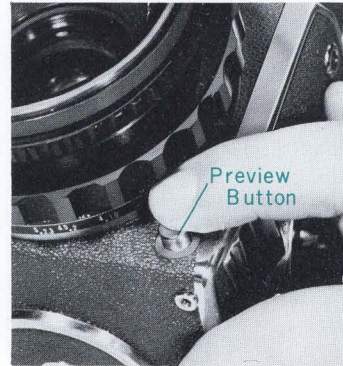

Seeing the depth of field (Range of sharp focus) by closing down the diaphragm to the preselected aperture. (Critical focussing and viewing is done with full aperture)

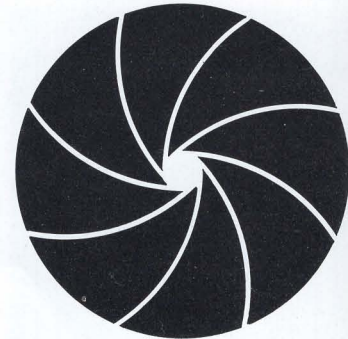

SHUTTER



The Vertical focalplane shutter has rubber-coated curtains and speeds are set by a single non-rotating knob.

Furthermore, through a special stabilizing device, there is evenly balanced exposure across the large film area even at high shutter speeds.

High quality miniature ball bearings are used. The shutter curtain travels across the 55mm film gate in 15~16 milliseconds. Intermediate shutter speeds can be selected. The X setting for electronic flash (strobe) represents 1/40 second.

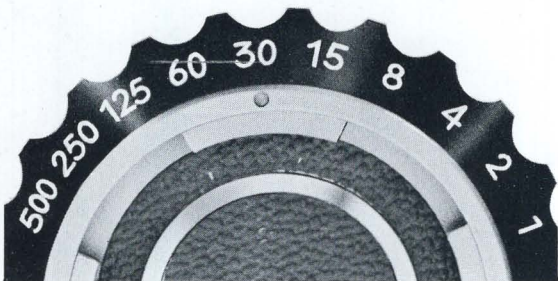

(1) SHUTTER DIAL :

“B” stands for “Bulb”: press to open, release to close shutter. “1” is one second; “2” is $\frac{1}{2}$ second; “500” is $1/500$ second, etc.

“X” represents $1/40$ second and is the fastest shutter speed with which electronic flash can be used. Any faster settings will result in partial non-exposure. (See “Flash”, page 14)

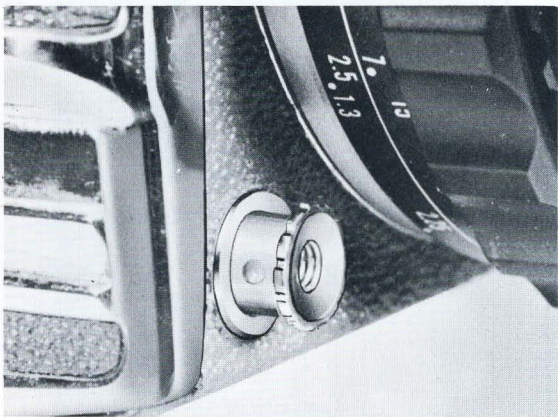

(2) SELECTING THE SHUTTER SPEED :

The shutter dial turns either right or left. The dial may be set for intermediate shutter speeds. Settings may be selected either before or after the shutter is wound.

(3) COLORS DEVIDES OF SHUTTER DIAL :

The red, white, green and yellow colors of shutter dial numbers are color codes for flash synchro photography. (See “Flash”, page 14)

CABLE RELEASE :



Having selected the shutter and diaphragm aperture, advance the film by turning the film winding knob clockwise to a film stop. Focus the lens and you are now ready to make the exposure.

To avoid camera move-

ment, it is desirable to use a cable release when a slow shutter speed is used. Cable release sockets are provided both on the body release button and below the depth-of-field preview button. The latter is easier to use.

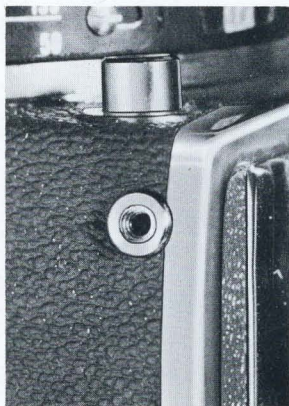

TIME EXPOSURE DEVICE AND

Time Exposure Device
When "T"(Time) exposure is desired, set the shutter speed dial at "B", depress the body release button and turn the tip of the button counter-clockwise to hold it in place.

This will lock the shutter open. To close the shutter and to return the mirror, turn the tip of the button clockwise.

SAFETY LOCK :

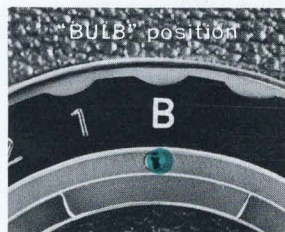

SAFTY LOCK :

The body release button has a safety lock. When the camera is carried with shutter cocked, it is best to set the safety lock. To set the safety lock, rotate the tip of the release button clockwise.

When the red dot is inside position, shutter is locked.

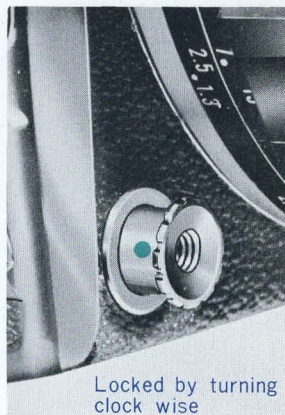

■ FLASH

The Bronica flash terminal accepts a standard connecting cord. (German Type)

USING NECK STRAP :

The shoulder strap has coupling connectors at each end. Place these coupling connectors over the camera strap studs on each side of the camera and press in, then adjust strap length.

To remove, lift or raise the metal wings on camera strap stud and simultaneously lift off the coupling connector.

Shutter Speed Flash Bulb	B.	1	2	4	8	15	30	60	125	250	500	X
F Bulb	[Hatched bar from B. to 15]											
M Bulb	[Hatched bar from B. to 125]											
X (Strobe)	[Hatched bar from B. to 15]											(1/40) [Hatched box]
FP Bulb	[Hatched bar from B. to 500]											
Shutter dial Color indication	red	green				white					yellow	



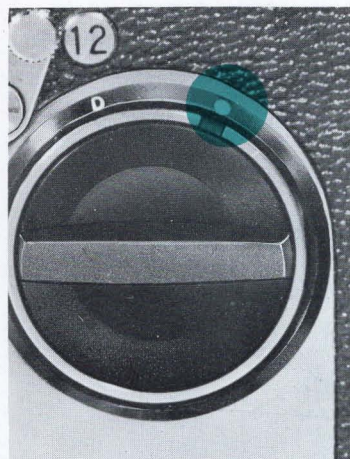

MULTIPLE EXPOSURE DEVICE :

Modern commercial photographers often employ the technique of double and triple exposures. The Zenza Bronica Model-C has an original system to stop the advancing of film and to wind the shutter only.

(1) Make one ordinary exposure. It is necessary to consider the position and construction of the first exposure and the second exposures.

(2) For double or triple exposures turn the multiple exposure knob to "D" and then wind the shutter. You can now make a second and third exposure on the same film without advancing the film.

Note :

Be sure to return the multiple exposure knob to its "Off" position without fail after taking the multiple exposures.

When loading film, please check the multiple exposure knob position before advancing the film



EXPOSURES SETTING DEVICE :

The ordinary Brownie size roll film (120Type) allows twelve 6x6 exposures, but the new 220 Type roll film takes 24 exposures.

—(Using)—

(1) The upper right picture shows the lever position when using the twelve exposure film (120 Type). In this case, after the 12 exposures are made, the film advance crank will wind sufficiently until there is no resistance.

(2) The lower right picture shows the lever position when using the 24 exposures roll film. (220 Type).

When using 24 exposure roll film, the lever should be in this position.

Wind sufficiently until 24 exposures are made and the film advancing free,

(Remarks)

(1) Switch lever may be moved to the 24 exposure position at any time, if you have forgotten to do so before loading.

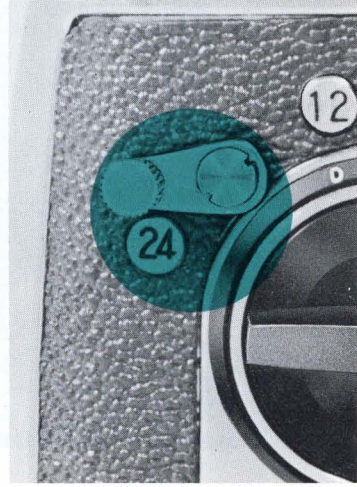

■ INTERCHANGING LENSES



To Remove Lens :

1. Extend lens by turning helicoid to closest focus position.
2. Press bayonet lock with thumb, and twist to left. (counter clock wise), Remove lens by pulling straight out.

To Mount Lens :

1. Line up red dots on lens and mount. Insert gently to full stop. Twist to right (clockwise) until bayonet lock snaps closed.

The interchangeable lens system of the Zenza Bronica Model-C can be used with earlier model bayonet type Bronica cameras, The screw thread (diameter 57mm, pitch 1mm) shown at lower right is new with Model C, and permits extension tube sets and certain very long telephoto lens to be mounted

Bayonet lock

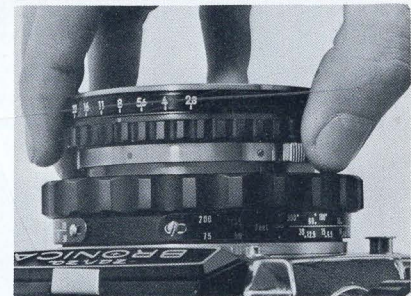

Thread for Telelenses and Extension tube set.

NIKKOR INTERCHANGEABLE LENSES

■ Nikkor 50mm F: 3.5

Lens construction:
6 groups; 6 elements
Minimum aperture: F: 22
Angle of view: 77°
Auto Diaphragm
Closest Distance: 33cm
Filter size:
82mm serew type
Weight: 460g.



■ Nikkor 75mm F: 2.8

Lens construction:
4 groups; 5 elements
Minimum aperture: F: 22
Angle of view: 55°
Auto Diaphragm
Closest Distance: 60cm
Filter size: 67mm screw
type or series VIII
Weight: 230g.



■ Nikkor 135mm F: 3.5

Lens construction:
3 groups; 4 elements
Minimum aperture: F: 22
Angle of view: 33°
Auto Diaphragm
Closest Distance: 1.6m
Filter size: 67mm
screw type or series VIII
Weight: 410g.

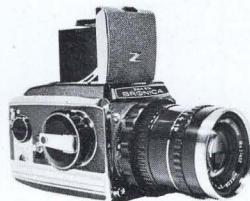

■ Nikkor 200mm F: 4 (with

hood and close-up lens)
Lens construction:
5 groups; 5 elements.
Minimum Aperture: F: 32
Angle of view: 21°
Auto Diaphragm
Closest Distance: 2.8m
Focussing range with
close-up lens: 1.53m - 3m
Filter size: 67mm screw
type or series VIII
Weight: 750g.



■ HELICOID LENS MOUNT

When using the bellows attachment for close-up photographs or a large caliber interchangeable lens (400mm) and over fitted with helicoid focussing, remove the Camera helicoid mount and attach the bayonet adapter to the front of body mount as shown in lower right picture

(1) Press the Helicoid retaining lock button and twist the helicoid lens mount to the left (counter-clockwise) and then remove the Helicoid.

(2) To return the Helicoid, insert in to body mount, lining up the red dots on Helicoid mount and body mount. Twist the Helicoid mount to right (clockwise) until Helicoid retaining lock snaps closed.

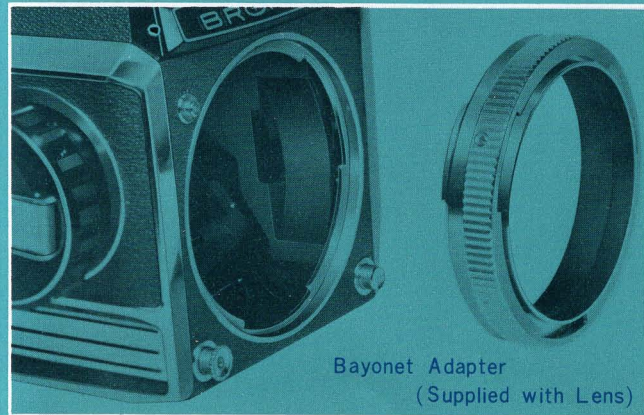
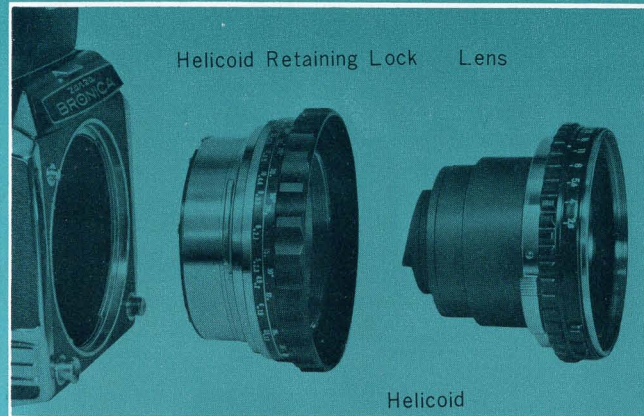

■ USING FOCUSING HOOD :

The focusing hood of the Zenza Bronica Model-C can easily be removed and inserted. It is possible to use both the prism finder for eye-level focusing and the outdoors magnifying hood which is adjustable for individual eyes.

(1) Press upward the focusing hood retaining lock on the front of camera body name plate and then remove.

(2) When inserting the focusing hood, match the two tips on the back side of the focusing hood frame and the two holes on the back side of the focusing hood.

Press down and lock the front side of the focusing hood.



Penta prismfinder Model A

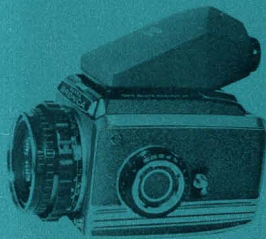

Magnifying Hood

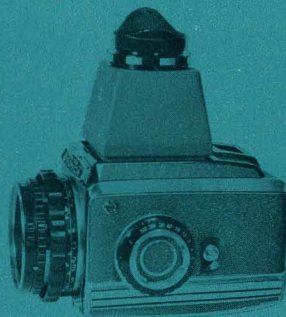

CLOSE-UP PHOTOGRAPHS

With the Zenza Bronica Model-C 75mm standard lens, you are able to approach up to 60cm from the subject to the surface of the film with full extension of the Helicoid, The 50mm wideangle lens goes to 33cm; the 135mm telephoto lens to 1.6m; and the 200mm telephoto lens to 3.4m. (With the close-up lens on the 200mm, you can take photographs as close 1.53m)

If you wish to photograph the subject even closer, use the special Bronica extension ring set or bellows attachment.

■ SPECIAL EXTENSION RINGS SET FOR MODEL C.

Insert the desired extension ring between the Helicoid and the lens.

(CA Ring)

The CA closeup ring has an aperture preview lever. Press this lever to open the aperture; when this lever is released, the aperture will close down.

(CB Ring)

For closer pictures, use an additional CB ring on top of the CA ring.

(CC.CD Ring)

The CD ring is twice as deep as the CC ring, see chart at right for various combinations.

■ BELLOWS ATTACHMENT MODEL C.

If you wish to take a wide range of close-up photographs, rather than using the extension ring set, this attachment is most convenient. The Bronica bellows attachment model C is used with the bayonet adaptor on the camera body mount. When using at the shortest extension with the standard 75mm lens, the magnification of picture is 0.9 times.

When using at the longest extension with 75mm standard lens, the magnification of picture is 2.9 times.

This attachment is equipped with the vertical and horizontal "Swing and tilt" device.

■ CA Ring



Preview Lever

■ CB Ring



■ CC Ring



■ CD Ring

Lenses No. of Tube	Stroke (mm)	NIKKOR 50mm F 3.5		NIKKOR 75mm F 2.8		NIKKOR 135mm F 3.5		NIKKOR 200mm F 4	
		Magnification Rate	Exposure Multiple Rate	M. R.	E. M. R.	M. R.	E. M. R.	M. R.	E. M. R.
CA Ring	14~48	0.56	2.4	0.36	1.9	0.21	1.5	0.14	1.3
CA+CA	28~42	0.84	3.4	0.54	2.4	0.31	1.7	0.21	1.5
CA+CB+CC	42~56	1.12	4.5	0.72	3.0	0.41	2.0	0.28	1.6
CA+CB+CD	56~70	1.40	5.8	0.90	3.6	0.52	2.3	0.35	1.8
(A+CB+CC+CD)	70~84	1.68	7.2	1.08	4.3	0.62	2.6	0.42	2.1

★Magnification Rate and Exposure Multiple Rate mentioned above shown in the Lenses closest position.

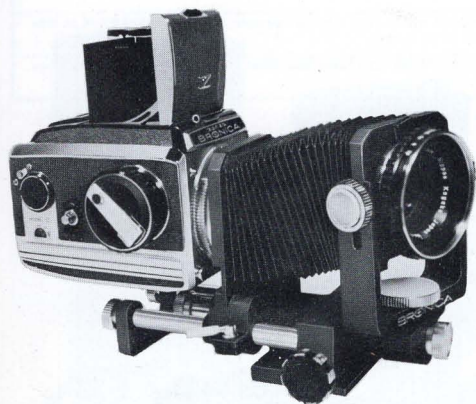

■ Fixed by the Lens reversing Ring

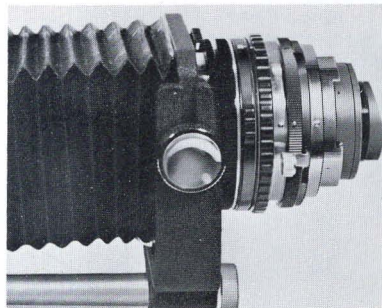

■ Shortest 60mm

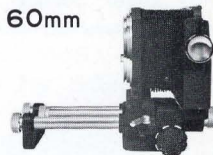

■ Longest 214mm

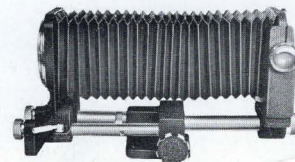

FILTERS:

Bronica filters are high grade filters having a special finish with superior surfaces.

The 50mm wide-angle lens requires 82mm, screwtype filters. The other lenses (75mm~200 mm lenses) can be used either with 67mm screwtype filter or Series VIII filters together with filter retaining ring as shown in left lower corner picture.

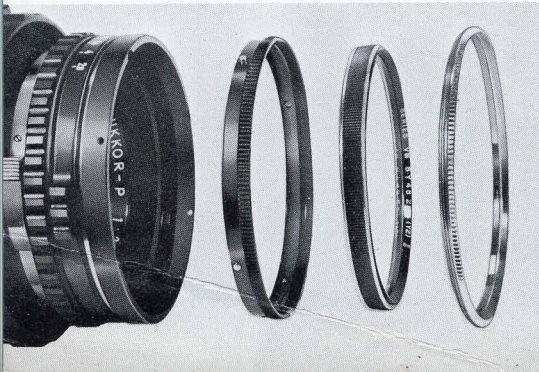

FOR MONOCHROME	Color Number	Color	Exposure Magnification				Effect of Filters
			*B type panchromatic film		*C type panchromatic film		
			Daylight	Art. Light	Daylight	Art. Light	
SL-39	UV	Transparent	1	1	1	1	Absorbs ultra-violet rays which results in a clear image.
SY-44	Y1	Light Yellow	1.5	1.3	1.5	1.2	Gives a clear image of sky and background in natural contrast.
SY-48	Y2	Yellow	2.0	1.5	2.0	1.5	Shades down reds and yellows. Good contrast. For general use.
SO-56	YA3	Amber	4.0	3.0	4.0	2.0	Brings out cloud effect. Strong contrast
SR-60	R1	Red	8.0	4.0	6.0	3.0	Gives greater contrast. For perfect infra-red photography with infra-red film
G-55	P00	Yellowish Green	2.5	2.0	4.0	3.0	Gives natural contrast with panchromatic film.

*B type panchromatic films: Konipan S, SS, Neopan S, SS, Plus X, Double X and Veri-Chrome. *C type panchromatic films: SSS class films and Tri-X.

FOR COLOR	Color	Conversion ratio for color temperature *Dekamired value	Exposure Magnification	Classification of color film	Effect of Filter
L-1A	Light Violet	0	1	Daylight type of Tungsten	Absorbs ultra-violet rays to prevent bluish appearance on background. Adjusts natural color balance. Used for lens protection.
O-85A	Orange	+1.2	2	Tungsten type	Conversion filter for tungsten type color film in daylight.
O-80A	Dark Blue	-1.2	2.5	Daylight type	Conversion filter for daylight type color film under artificial light.
B-82C	Bue	-4.0	1.5	Daylight type	Absorbs reddish color when photographs are taken before 9 A.M. or after 3 P.M. in daylight.
O-81B	Amber	+4.0	1.5	Daylight type	Absorbs bluish color when photographs are taken in cloudy or shadowy conditions.

* (+) Reduction of color temperature. (-) Increase of color temperature

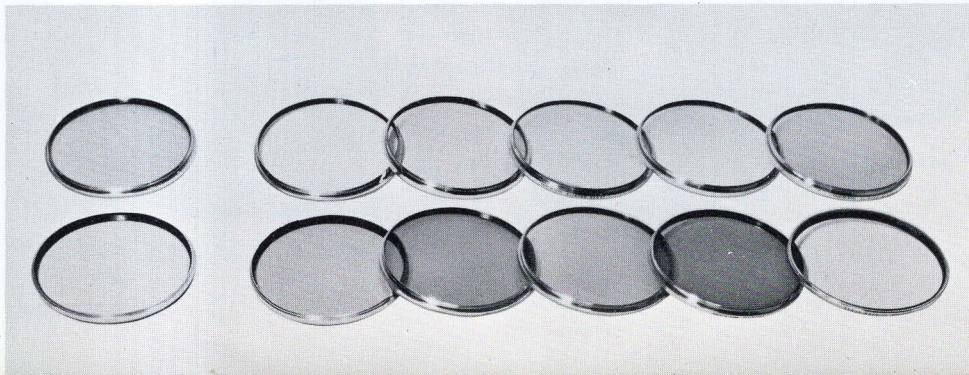



▲ Pentaprism Finder Model A



▲ Magnifying Hood

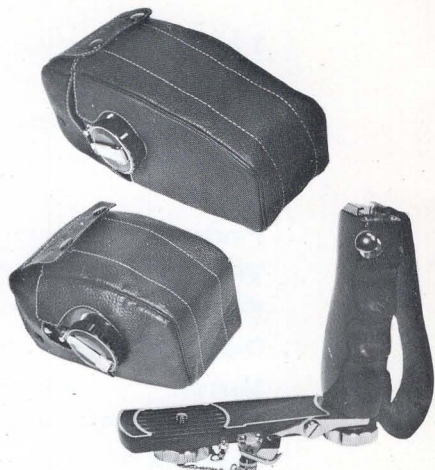

▲ Hand Grip



◀ Leather case for 200mm lens



◀ Leather case for 135mm lens



◀ Leather case for 50mm lens

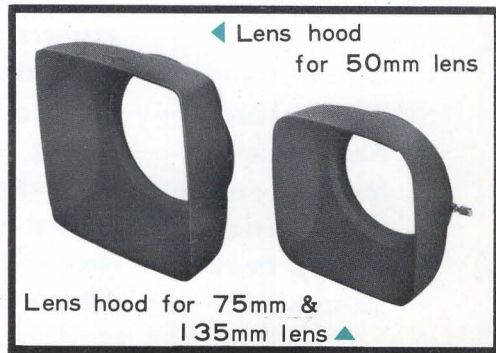

◀ Lens hood
for 50mm lens

Lens hood for 75mm &
135mm lens ▲

SPECIFICATIONS

- Type** $2\frac{1}{4}'' \times 2\frac{1}{4}''$ (6cm \times 6cm) Single lens reflex camera.
- Film** 120 roll film, 12 exposures and 220 roll film, 24 exposures.
- Standard lens** Nikkor 75mm F2.8 fully automatic preset diaphragm, 4 group 5 element.
- Lens mount** Bayonet type (BRONICA mount), also equipped with screw mount (57mm \times 1mm pitch), Large bayonet mount for long telephoto lenses.
- Finder** Fresnel lens and large magnifier.
- Viewfinder Hood** Interchangeable with pentaprism finder or magnifying hood.
- Focusing** Helicoid type, stroke 14mm, rotating angle of focussing ring 250°
- Distance Scale** For 75mm, 50mm, 135mm and 200mm lenses.
- Mirror** Flip down, instant return, automatic mirror system.
- Diaphragm** Fully automatic diaphragm - 75mm, 50mm, 135mm and 200mm lens.
- Depth-of-Field** Depth-of-field can be checked by pressing preview button.
- Shutter** Vertically operating focal plane shutter, non-rotating single shutter dial, B, 1, 1/2, 1/4, 1/8, 1/15, 1/30, 1/60, 1/125, 1/250, 1/500 and "X" (1/40), "T" (Time) exposure by using shutter release lock device. Intermediate shutter speeds.
- Synchro** Automatic switch-over synchronization system.
- Film Loading** Separate film holder, automatic film winding system by matching with film start mark.
- Film Winding** Winding crank or knob,.
- Multiple exposure**... By turning the Multiple exposure knob.
- Film Counter** Automatically returns to "0".
- Camera Body** Made of 18-8 Stainless Steel, bright polished finish.
- Demensions** 100mm \times 100mm \times 140mm.

ZENZA BRONICA INDUSTRIES, INC.

25, 2-chome, Minami-Tokiwadai,
Itabashi-ku, Tokyo, Japan.

Phone: 956-3101