

MINOLTA AF 50mm F1.7 (2550-100)

MINOLTA MAXXUM AF 50mm F1.7 (2550-600)

LENS

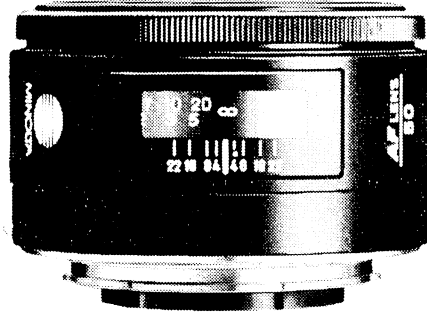
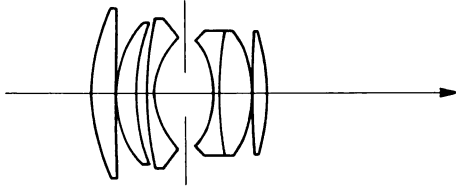

Construction : 6 elements in 5 groups
Type : Modified-Gauss type
Coating : Minolta Achromatic
Angle of view : 47°
Lens mount : Minolta A mount
Lens signal contact : 5 contacts
Diaphragm : Automatic preset diaphragm
f No. : Maximum··1.7
Minimum··22
Full-stop setting··7.5 stops
Diaphragm blade : 7 blades

DIMENSIONS & WEIGHT

Dimensions : ϕ 65.5 (max. diameter) ×
38.5mm (max. length)
Weight : 195 g
Filter-thread diameter : ϕ 49mm (P=0.75)
Lens hood : Built-in

FOCUSING

Focusing : AF, FA, M
Type : Double helicoid system
Minimum focusing distance : 0.45m

ACCESSORIES

Lens case (LH-1011)

Distance scale : $\frac{1.5 \quad 1.7 \quad 2 \quad 2.5 \quad 3 \quad 4 \quad 5 \quad 7 \quad 10 \quad 20}{0.45 \quad 0.5 \quad 0.55 \quad 0.6 \quad 0.7 \quad 0.8 \quad 1 \quad 1.2 \quad 1.5 \quad 2 \quad 3 \quad 5}$ (ft)
(m)

Infrared correction index : Yes

Depth-of-field scale : 4 8 16 22

I N D E X

Part No.	Page	Part No.	Page	Part No.	Page
2550-0020-----	1				
2550-0030-----	3	2550-1402-----	2	Washer	
2550-0040-----	3	2550-1420-----	2	9793-1736-50-----	1
2550-0113-----	2	2550-1422-----	2		
2550-0232-----	2	2550-1424-----	1		
2550-0240-----	2	2550-1431-----	1		
2550-0371-----	2	2550-1444-----	1		
2550-0430-----	1	2550-1445-----	1,2		
2550-0501-----	1	2550-1446-----	2		
		2513-1449-----	2		
2550-1112-----	2				
		2550-1641-----	1		
2550-1230-----	1				
2550-1236-----	1	Screw			
2550-1241-----	1	9611-1422-07-----	1		
2550-1242-----	1	9611-1625-07-----	2		
		9611-1635-07-----	1,2		
2550-1372-----	2	9611-1640-07-----	1		
2550-1374-----	2	9611-2040-04-----	2		
2550-1375-----	2				
2550-1379-----	1	9612-1655-07-----	1		
2550-1381-----	2				
2550-1382-----	1	9763-1740-07-----	1		

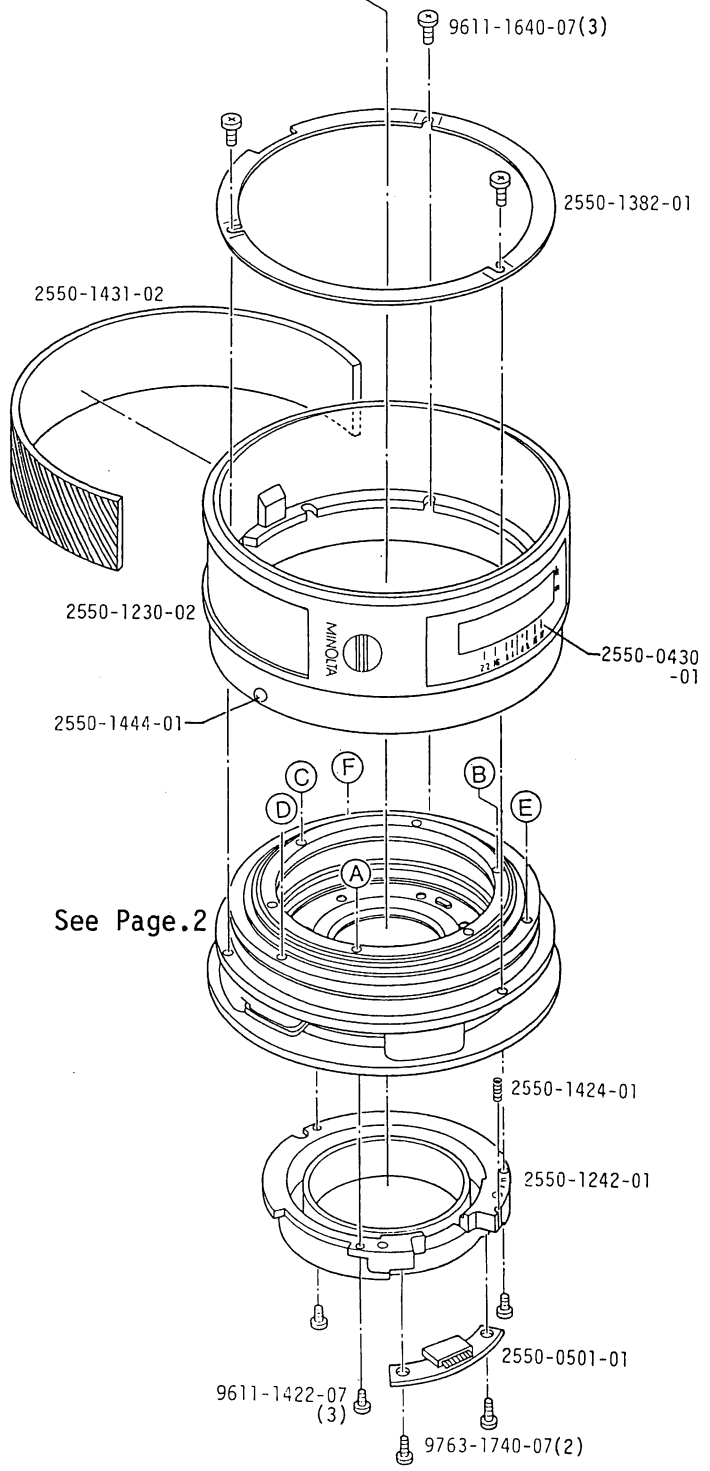
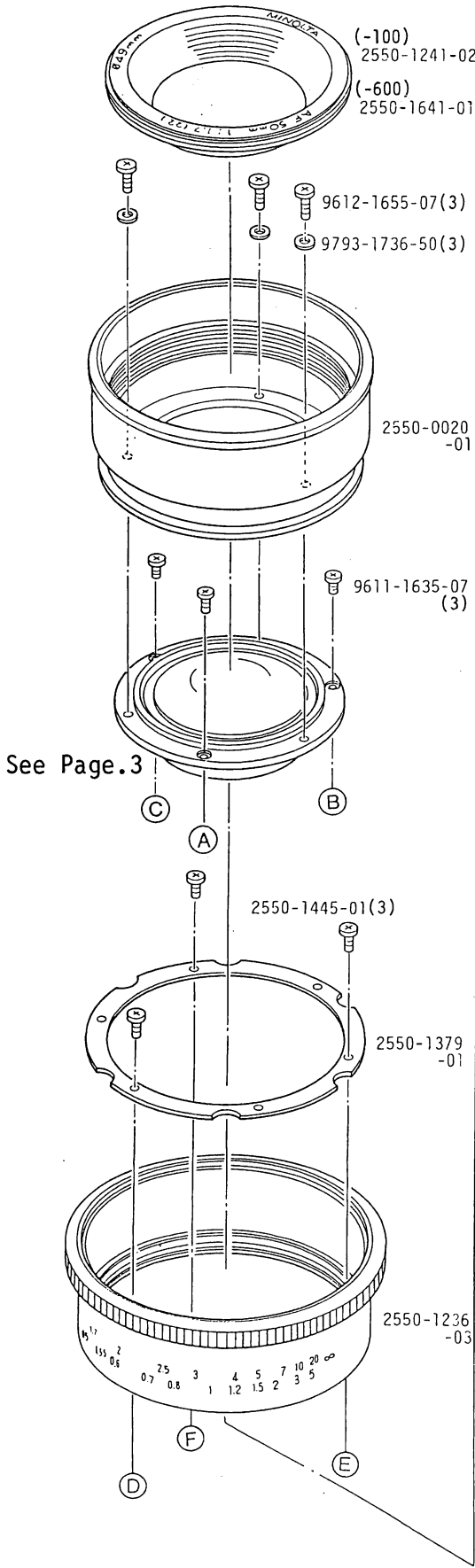

Part No.	Part Name		Qty.
2550-0020-01	Hood set	フードセット	1
2550-0430-01	Distance scale window set	距離表示窓セット	1
2550-0501-01	Lens contact board set	信号基板セット	1
2550-1230-02	Outer ring	固定保持環	1
2550-1236-03	Focusing ring	距離リング	1
2550-1241-02	Name plate (-100)	飾り環	1
2550-1242-01	Rear light shield ring	後遮光筒	1
2550-1379-01	Focusing ring set plate	距離リング縮付板	1
2550-1382-01	Outer ring set plate	固定保持環縮付板	1
2550-1424-01	Spring	アーススプリング	1
2550-1431-02	Leather	貼皮	1
2550-1444-01	Bayonet point	バヨネット標点	1
2550-1445-01	Screw	止めねじ	3
2550-1641-01	Name plate (-600)	飾り環	1
9611-1422-07	Phillips type screw	十字穴付なべ頭小ねじ	3
9611-1635-07	Phillips type screw	十字穴付なべ頭小ねじ	3
9611-1640-07	Phillips type screw	十字穴付なべ頭小ねじ	3
9612-1655-07	Phillips type screw	十字穴付なべ頭小ねじ	3
9763-1740-07	Tap tite screw	十字穴付半丸頭タップタイトねじ	2
9793-1736-50	Washer	薄ワッシャー	3

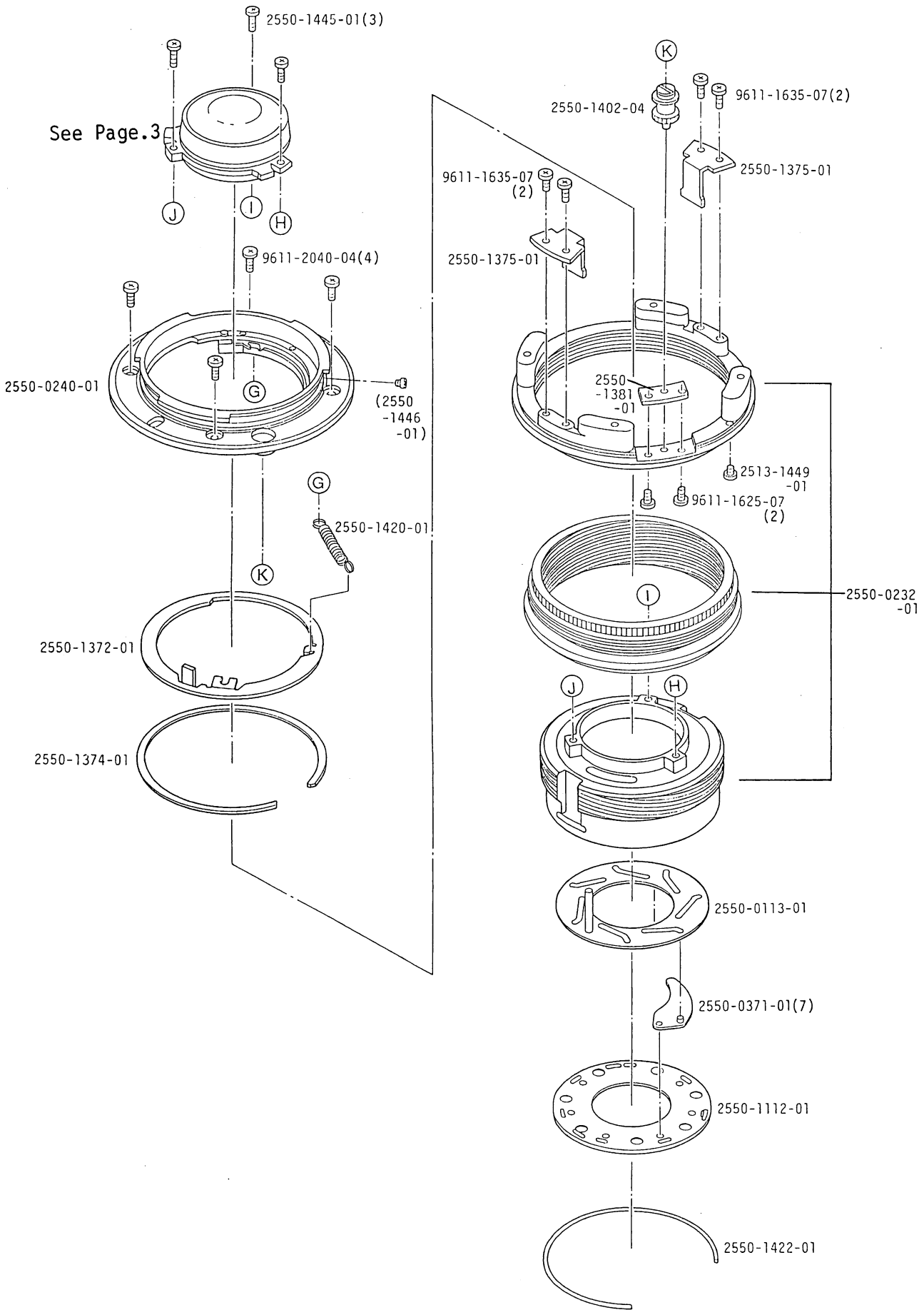

Part No.	Part Name		Qty.
2550-0113-01	Diaphragm operation plate set	絞り操作板セット	1
2550-0232-01	Helicoid set	ヘリコイドセット	1
2550-0240-01	Bayonet mount set	バヨネットマウントセット	1
(2550-1446-01)	Screw	ストッパービス	1
2550-0371-01	Diaphragm blade set	絞り羽根セット	7
2550-1112-01	Diaphragm pressure ring	絞り押え環	1
2550-1372-01	Preset ring	プリセットリング	1
2550-1374-01	Preset ring pressure	プリセットリング押え	1
2550-1375-01	Helicoid key	直進キー	2
2550-1381-01	Axis receiver-B	軸受B	1
2550-1402-04	Coupler	カプラー	1
2550-1420-01	Main spring	メインスプリング	1
2550-1422-01	Diaphragm pressure ring spring	絞り押え環スプリング	1
2550-1445-01	Screw	止めねじ	3
2513-1449-01	Screw	止めねじ	1
9611-1625-07	Phillips type screw	十字穴付なべ頭小ねじ	2
9611-1635-07	Phillips type screw	十字穴付なべ頭小ねじ	4
9611-2040-04	Phillips type screw	十字穴付なべ頭小ねじ	4

AF 50mm F1.7(22) Code No.2550-100
 MAXXUM AF 50mm F1.7(22) Code No.2550-600

■ When repairing following parts, must be checked resolving power by projection.

■ 下記部品を修理した場合は、必ず投影解像力を確認して下さい。

①: The influential lens element in the lens performance. (Number shows in order.)

①: レンズ性能によく影響するレンズ。(数字は順位を示す)

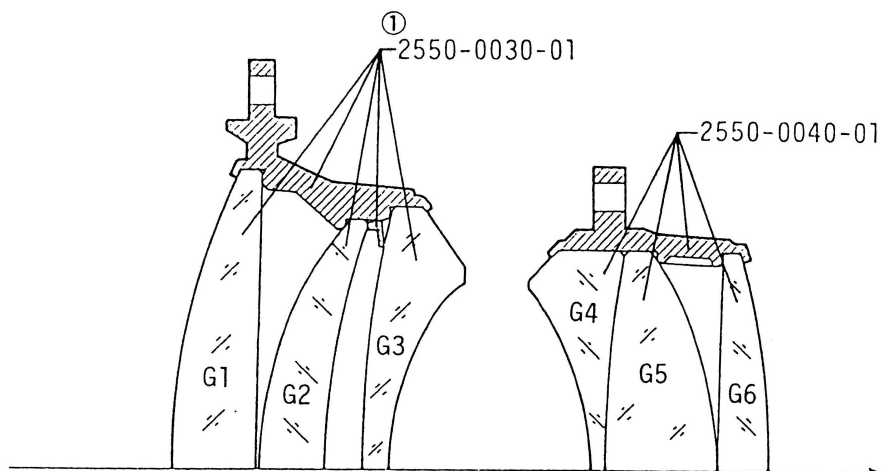

Part No.	Part Name		Qty.
2550-0030-01	Front lens group set	前玉群セット	1
2550-0040-01	Rear lens group set	後玉群セット	1

REPAIR GUIDE

■ The contents of this manual are in accordance with the assembling procedure. Therefore, follow the reverse procedure when disassembling.

— Description of marks used —

- **B** : Adhesive
- **S** : Solvent
- **A** : Anti-diffusion compound
- **G** : Lubricant
- **T** : Tool
- : Point of assembling and general caution

■ Assembling and adjusting procedure

	Page
1 Outer helicoid, Middle helicoid, Inner helicoid assembling	1
■ Helicoid position, level adjusting	1
2 Diaphragm blade, Coupler, Bayonet mount, Rear lens group assembling	2
3 Outer ring, Focusing ring, Rear light shield ring, Lens contact board set assembling	3
■ Aperture diameter adjusting (including pre-check)	3
4 Front lens group, Hood set, Name ring assembling	4
■ Flange back adjusting	4
■ Projection resolving power checking	4
■ Aperture diameter checking	4
■ General function checking	4
■ Description of focusing	5
■ Wiring schematic diagram and Printed wiring diagram	5

■ Precautions

- Since this lens uses many resin parts, keep the following in mind when assembling and adjusting.
 - Use Flonsolve or alcohol when cleaning. Never use the thinner, ketone or ether.
- Since MOS-IC is used in this lens, it is necessary to take special precautions about static electricity. When performing repairs, use the conductive mat without fail, as shown.

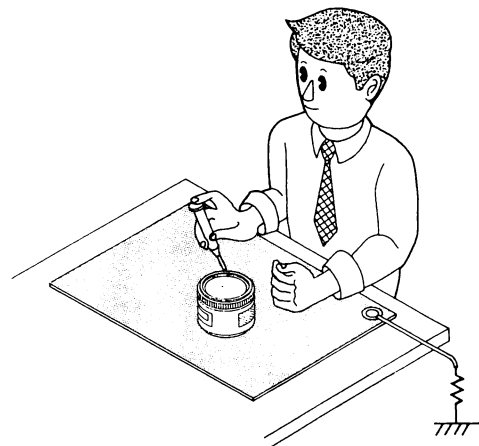

1 Outer helicoid, Middle helicoid, Inner helicoid

- Assemble the parts in the order of ①→⑦. After assembling, wipe off overflowed grease.
- While assembling parts ①→④, perform the adjustments of helicoid position and level. (See Fig. 1)

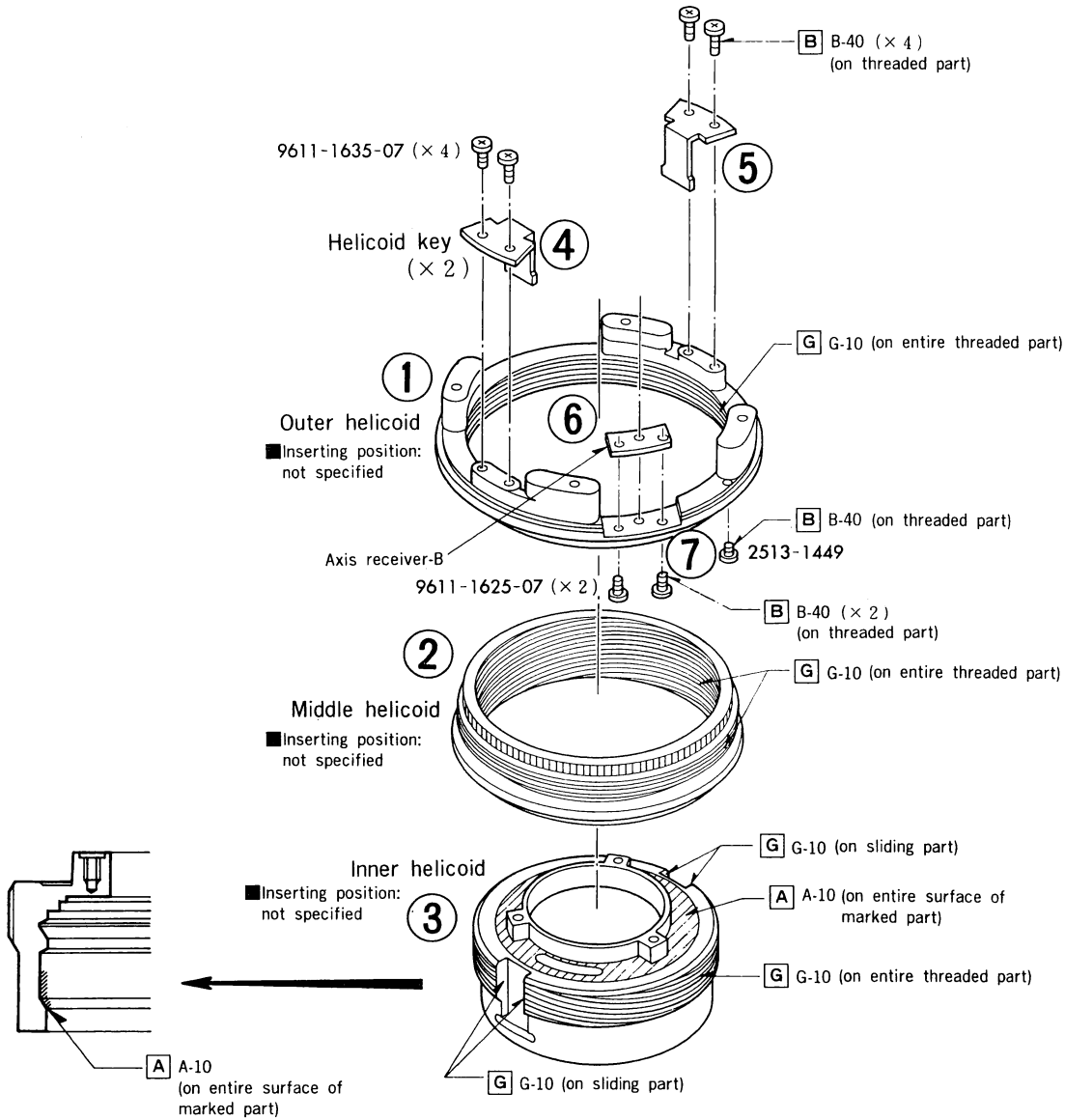

■ After assembling, check the helicoid functioning (stiffness, smoothness, catching).

■ Fig. 1 Helicoid position, level adjusting.

● Set the helicoid lever as shown, at infinity (∞) setting.

● Axis receiver-B position and diaphragm connecting pin groove should be in position as shown when installing helicoid key.

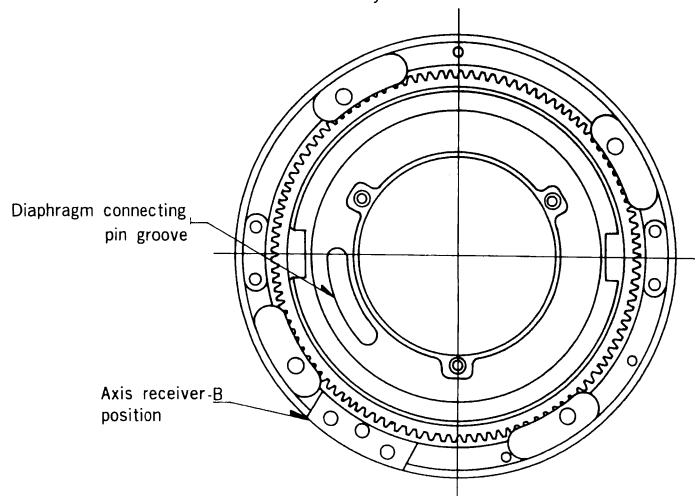
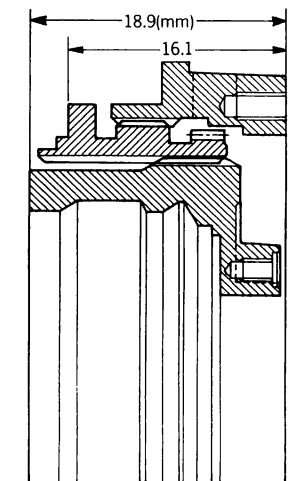

2 Diaphragm blade, Coupler, Bayonet mount, Rear lens group

Assemble the parts in the order of ① → ⑦.

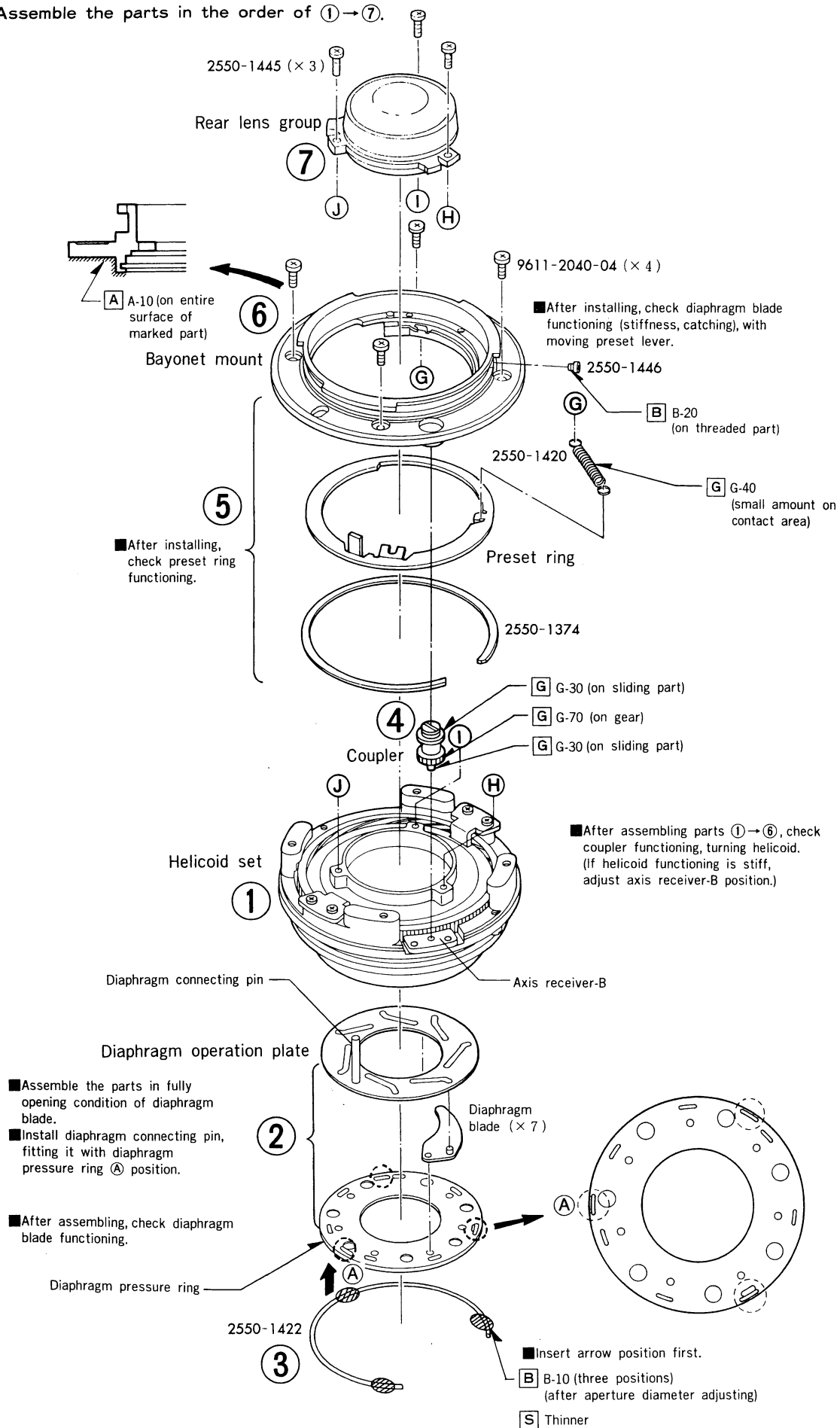

3 Outer ring, Focusing ring, Rear light shield ring, Lens contact board set

■ Assemble the parts in the order of ① → ⑧. After assembling, perform aperture diameter adjusting (including pre-check, referring to General checking/adjusting procedure on p. 8, 9).

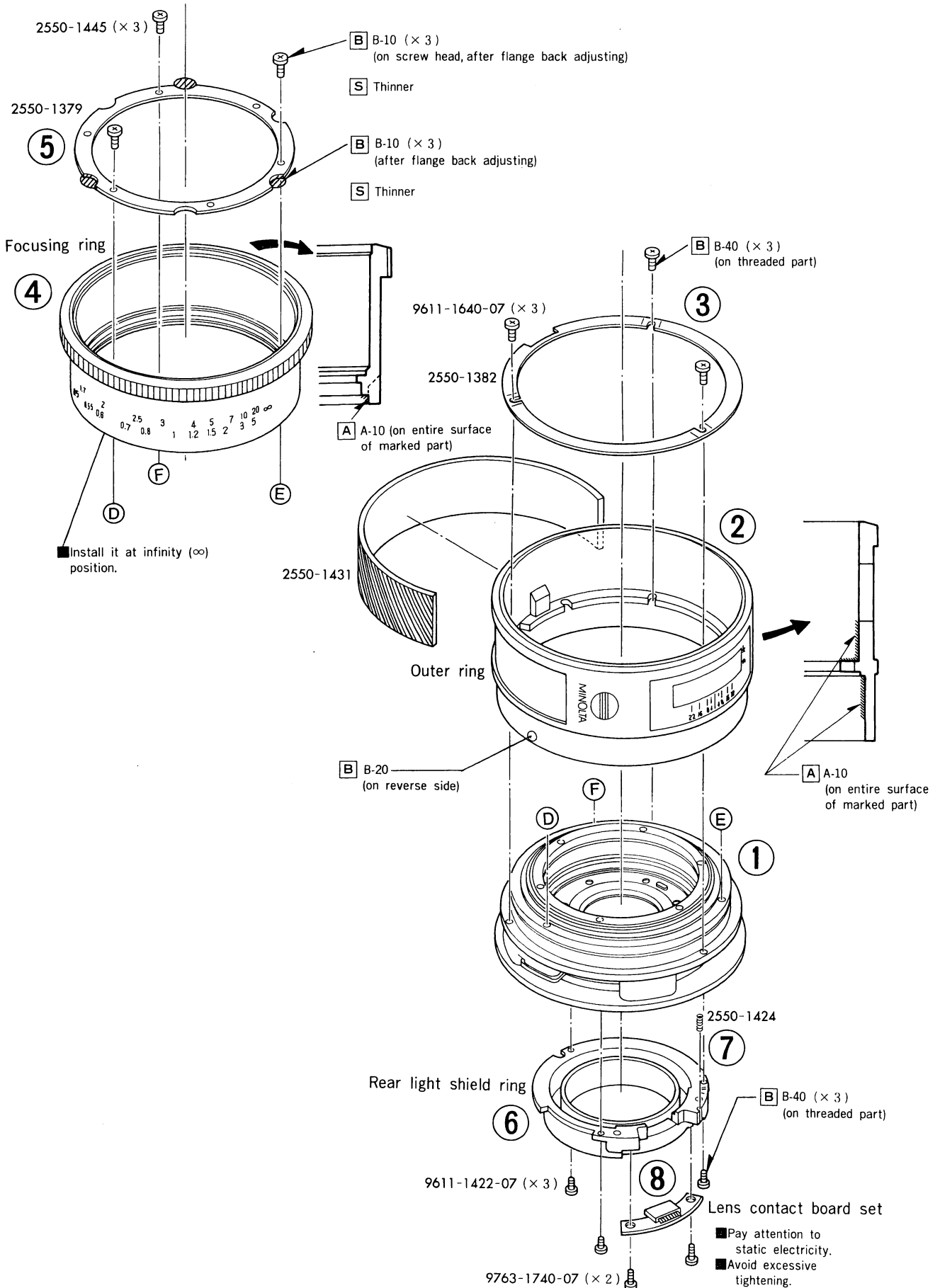

4 Front lens group, Hood set, Name ring

■ Assemble the parts in the order of ①→③.

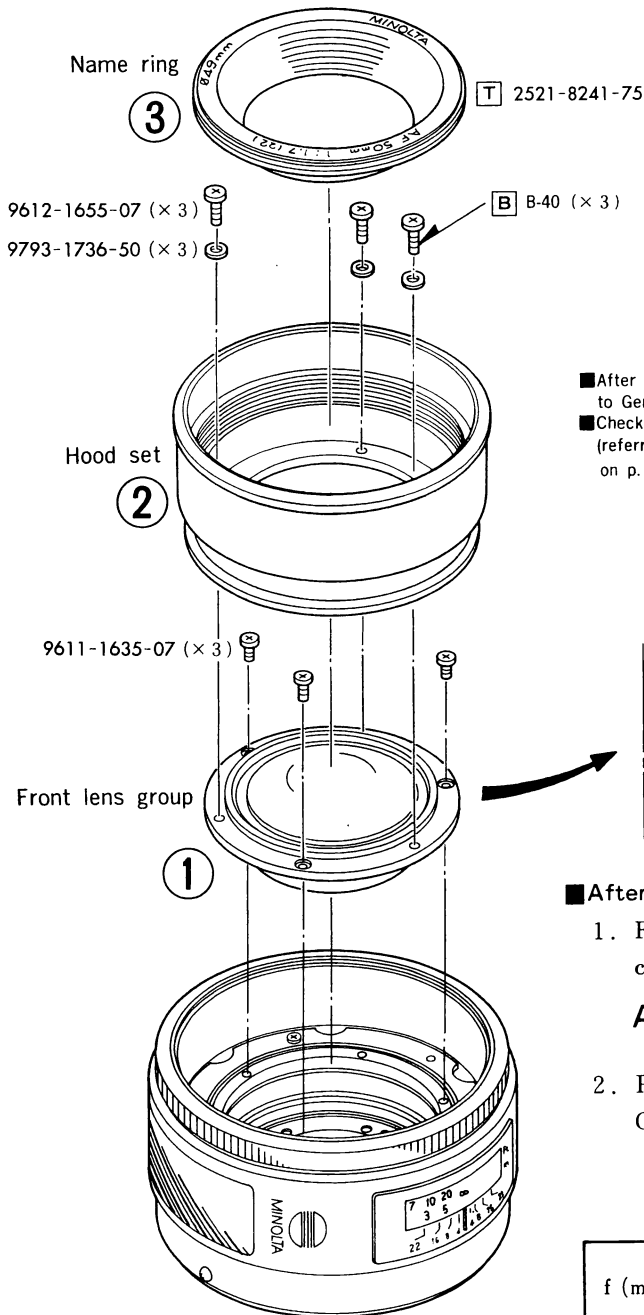

■ After assembling, check aperture diameter (referring to General checking/adjusting procedure on p. 9).
 ■ Check general functioning. (referring to General checking/adjusting procedure on p. 14).

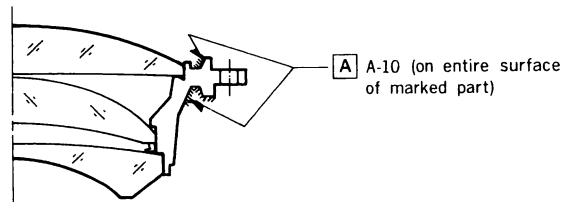

■ After assembling, perform the following adjusting.

1. Flange back adjusting (referring to General checking/adjusting procedure on p. 1).

Allowable range $f' F = 44.56^{+0.02}_0$

2. Projection resolving power checking (referring to General checking/adjusting procedure on p. 6).

Allowable range for Servicing (min.)

f (mm)	Distance D(m)	Center (y' = 0 mm)	y' = 15 mm	
			S	M
50	0.9-2.15	100	32	32

S : Sagittal image
 M : Meridional image

If out of allowable range, take following measures.

- Change installing position of front/rear lens group. (Rotate lens group 120°.)
- Replace front/rear lens group.

Description of focusing

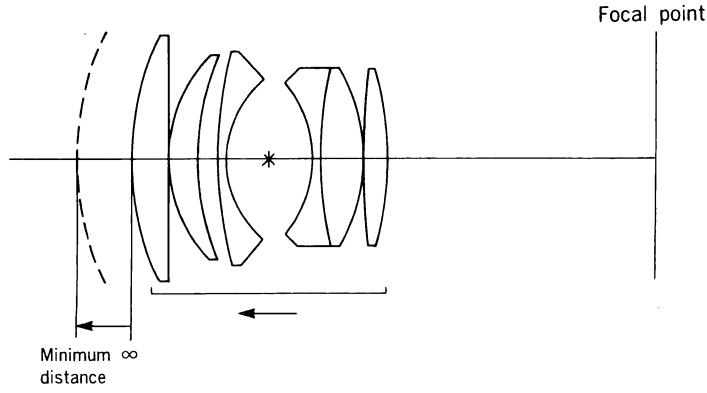

- Double helicoid system.
By rotating AF coupler or focusing ring, all optical lenses move in the same way.

Wiring schematic diagram, printed wiring diagram

