

SAMSUNG

Valuable image in my hand



GX 1S User's Manual

Thank you for buying a Samsung Camera.

This manual will guide you through using the camera, including capturing images, downloading images and using the application software. Please read this manual carefully before using your new camera.

ENGLISH

FOR SAFE USE OF YOUR CAMERA

Thank you for buying a Samsung Digital Camera.

- Prior to using this camera, please read this user manual thoroughly.
- When you require After Sales service, please bring the camera and the cause of the camera malfunction (such as battery, Memory card etc.) to the After Sales centre.
- Please ensure that your camera is operating properly well before you intend to use it (e.g. for a trip or an important event) to avoid disappointment. Samsung Cameras take no responsibility for any loss or damages that may result from camera malfunction.
- Keep the manual in a safe place.
- * Microsoft, Windows and Windows logo are registered trademarks of Microsoft Corporation incorporated in the United States and/or other countries.
- * All brand and product names appearing in this manual are registered trademarks of their respective companies.

This manual contains instructions that will help you to use this camera safely and correctly. This will help prevent danger and injury to others.



DANGER

DANGER indicates an imminently hazardous situation which, if not avoided, will result in death or serious injury.



WARNING

WARNING indicates a potentially hazardous situation, which, if not avoided, could result in death or serious injury.



CAUTION

CAUTION indicates a potentially hazardous situation, which, if not avoided, may result in a minor or moderate injury.

Danger

- Do not attempt to modify this camera in any way. This may result in fire, injury, electric shock or severe damage to you or your camera. Internal inspection, maintenance and repairs should be carried out by your dealer or Samsung Camera Service centre.
- Please do not use this product in close proximity to flammable or explosive gases, as this could increase the risk of explosion.
- Should any form of liquid or a foreign object enter the camera, do not use it. Switch off the camera, and then disconnect the power source (batteries or AC Power Adapter). You must contact your dealer or Samsung Camera Service centre. Do not continue to use the camera as this may cause a fire or electric shock.
- Do not insert or drop metallic or inflammable foreign objects into the camera through access points e.g. the memory card slot and battery chamber. This may cause a fire or electric shock.
- Do not operate this camera with wet hands. This could pose a risk of electric shock.

DANGER

Warning

- Do not use the flash in close proximity to people or animals. Positioning the flash too close to your subject's eyes, may cause eyesight damage.
- When taking photographs, never point the lens of the camera directly into very strong light. This may result in permanent damage to your eyesight.
- For safety reasons keep this product and accessories out of reach of children or animals to prevent accidents e.g.:
 - Swallowing batteries or small camera accessories. If an accident should occur, please consult a doctor immediately.
 - There is the possibility of injury from the camera's moving parts.
- Batteries and camera may become hot during prolonged use which may result in camera malfunction. Should this be the case, allow the camera to sit idle for a few minutes to allow it time to cool.
- Do not recharge non rechargeable batteries. This may cause an explosion.
- Do not leave this camera in places subject to extremely high temperatures, such as a sealed vehicle, direct sunlight or other places of extreme variances in temperature. Exposure to extreme temperatures may adversely affect the camera's internal components and could cause a fire.
- When in use, do not cover the camera or AC Power Adapter. This may cause heat to build up and distort the camera body or cause a fire. Always use the camera and its accessories in a well-ventilated area.

Caution

- Leaking, overheating, or burst batteries could result in fire or injury.
 - Use batteries with the correct specification for the camera.
 - Do not short circuit, heat or dispose of battery in fire.
 - Do not insert the batteries with polarities reversed.
- Remove the batteries when not planning to use the camera for a long period of time. Batteries may leak corrosive electrolyte and permanently damage the camera's components.
- Do not fire the flash while it is in contact with hands or objects. Do not touch the flash after using it continuously. It may cause burns.
- If you are using the AC power adaptor be careful when moving the camera. After use, always switch off the camera before unplugging the adapter from the wall socket. Then make sure that any connector cords or cables to other devices are disconnected before moving the camera. Failure to do so may damage the cords or cables and cause a fire or electric shock.
- The Lens is attached to the camera body. Do not drop or press the lens by force. It may cause a camera malfunction.
- Do not pull the lens by hand or do not rotate the zoom ring quickly. It may cause a camera malfunction. Please be careful when using the lens.
- Do not extract the external flash from the camera by force. It may cause damage to the top of the camera.

PRECAUTIONS FOR BATTERY USAGE

- Only use specified batteries with this camera. Use of other batteries can cause overheating or explosion.
- Replace the batteries at the same time. Do not mix battery brands, type or an old battery with a new one. It may cause explosion or overheating.
- The battery should be inserted correctly with regard to polarity (+ and -) marked on the battery and the camera.
- AA lithium batteries, AA alkaline batteries and CR-V3 are not rechargeable. Do not disassemble the battery. Recharging and disassembling can cause explosion or overheating.

Contents

| | |
|--|---|
| FOR SAFE USE OF YOUR CAMERA | 1 |
| Danger | 2 |
| Warning | 2 |
| Caution | 3 |
| PRECAUTIONS FOR BATTERY USAGE | 3 |
| Contents | 4 |
| Contents of the Operating Manual | 8 |

Before Using Your Camera

| | |
|--|----|
| ● GX-1S Camera Characteristics | 10 |
| ● Checking the Contents of the Package | 11 |
| ● Names of Working Parts | 12 |
| ■ Camera | 12 |
| ■ LCD Monitor Indications | 14 |
| ■ Viewfinder Indications | 18 |
| ■ LCD Panel Indications | 20 |

Getting Started

| | |
|---|----|
| ● Attaching the Strap | 22 |
| ● Connecting to a Power Source | 23 |
| ■ Batteries | 24 |
| ■ Battery Level Indicator | 25 |
| ■ Approximate Playback Time (new batteries) | 25 |
| ■ Using the AC Adapter (Optional) | 26 |
| ● Using the memory card | 27 |
| ● Turning the Camera On and Off | 30 |
| ● Initial Settings | 31 |
| ■ Setting the Display Language | 31 |
| ■ Setting the Date and Time | 33 |
| ● Attaching the Lens | 35 |
| ● Adjusting the Viewfinder Diopter | 37 |

Basic Operations

| | |
|---|----|
| ● Basic Shooting Operation | 40 |
| ■ Holding the Camera | 40 |
| ■ Letting the Camera Choose the Optimal Settings | 41 |
| ● Selecting the Appropriate Capturing Mode for Scenes | 45 |





Contents

| | |
|---|----|
| ● Using the Zoom Lens | 46 |
| ● Using the Built-in Flash | 47 |
| ● Other Shooting Modes | 51 |
| ■ Continuous Shooting | 51 |
| ■ Self-Timer Shooting | 53 |
| ■ Remote Control Shooting (Remote Control F: Sold Separately) | 57 |
| ■ Using Mirror Lock Up Function to Prevent Camera Shake | 60 |
| ● Playing Back Still Pictures | 61 |
| ■ Playing Back Images | 61 |
| ■ Rotating Images | 62 |
| ■ Enlarging Playback Images | 63 |
| ■ Nine-Image Display | 64 |
| ■ Slideshow | 66 |
| ● Connecting the Camera to AV Equipment | 68 |
| ● Processing Images with Filters | 69 |
| ● Deleting Images | 71 |
| ■ Deleting a Single Image | 71 |
| ■ Deleting All Images | 72 |
| ■ Deleting Selected Images (from Nine-Image Display) | 73 |
| ● Protecting Images | 75 |
| ■ Protecting Images from Deletion (Protect) | 75 |
| ● Setting the Printing Service (DPOF) | 77 |
| ■ Printing Single Images | 77 |
| ■ Settings for All Images | 79 |
| ● Printing Using PictBridge | 81 |
| ■ Setting [Transfer Mode] | 82 |
| ■ Connecting the Camera to the Printer | 83 |
| ■ Printing Single Images | 84 |
| ■ Printing All Images | 86 |
| ■ Printing Images Using the DPOF Settings | 88 |
| ■ Disconnecting the Cable from the Printer | 88 |

Menu Reference

| | |
|------------------------------------|----|
| ● Using the Button Functions | 90 |
| ■ Capture Mode | 90 |
| ■ Playback Mode | 92 |
| ● Using the Menu | 94 |
| ■ How to Operate the Menu | 94 |

Contents

| | |
|--|-----|
| ■ [ Rec. Mode] Menu Setting Items | 96 |
| ■ [ Playback] Menu Setting Items | 96 |
| ■ [ X ↓ Set-up] Menu Setting Items | 97 |
| ■ [ C Custom Setting] Menu Setting Items | 98 |
| ● Using the Fn Menu | 100 |
| ■ Capture Mode | 100 |
| ■ Playback Mode | 101 |
| ● Using the Mode Dial | 102 |

Function Reference

| | |
|---|-----|
| ● Setting the Recorded Pixels and Quality Level | 106 |
| ■ Setting the Image Tone | 106 |
| ■ Setting the Recorded Pixels | 107 |
| ■ Setting the Quality Level | 108 |
| ■ Setting the Saturation/ Sharpness/ Contrast | 109 |
| ■ Setting the White Balance | 110 |
| ■ Setting the Sensitivity | 113 |
| ■ Setting the Colour Space | 115 |
| ● Focusing | 116 |
| ■ Using the Autofocus | 116 |
| ■ Setting the AF Mode | 119 |
| ■ Selecting the Focusing Area (Focus Point) | 120 |
| ■ Fixing the Focus (Focus Lock) | 122 |
| ■ Adjusting the Focus Manually (Manual Focus) | 124 |
| ● Setting the Exposure | 126 |
| ■ Effect of Aperture and Shutter Speed | 126 |
| ■ Selecting the Metering Method | 129 |
| ■ Changing the Exposure Mode | 131 |
| ■ Setting the Exposure | 140 |
| ■ Changing the Exposure and Shooting (Auto Bracket) | 142 |
| ● Using the Built-in Flash | 145 |
| ■ Compensating Flash Output | 145 |
| ■ Allowing Shooting while Charging Flash | 146 |
| ■ Flash Characteristics in Each Exposure Mode | 146 |
| ■ Distance and Aperture when Using the Built-in Flash | 148 |
| ● Using an External Flash (Optional) | 150 |
| ● Settings During Playback | 155 |
| ■ Changing Playback Display Method | 155 |

Contents

| | |
|--|-----|
| ■ Displaying Bright Portion Warning | 155 |
| ■ Setting the Slideshow Display Interval | 156 |
| ● Camera Settings | 157 |
| ■ Formatting the SD Memory Card | 157 |
| ■ Turning the Beep On and Off | 158 |
| ■ Changing the Date and Time and the Display Style | 158 |
| ■ Setting the World Time | 159 |
| ■ Setting the Display Language | 162 |
| ■ Turning the Guide Display On and Off | 162 |
| ■ Adjusting the Brightness of the LCD Monitor | 163 |
| ■ Selecting the Video Output Format | 163 |
| ■ Setting Auto Power Off | 164 |
| ■ Resetting the File Number | 164 |
| ■ Setting the Display Time | 165 |
| ● Resetting to Default Settings | 166 |
| ■ Resetting Rec. Mode/ Playback/ Set-up Menu | 166 |
| ■ Resetting the Custom Function Menu | 167 |

Software information

| | |
|---|-----|
| ● Software Notes | 170 |
| ● About the software | 171 |
| ● Setting up the application software | 172 |
| ● Starting PC mode | 173 |
| ● Removable Disk | 174 |
| ● Removing the removable disk | 176 |
| ● Digimax Master | 178 |

Appendix

| | |
|------------------------------|-----|
| ● Default Settings | 186 |
| ● Cleaning the CCD | 190 |
| ● Optional Accessories | 192 |
| ● Error Messages | 194 |
| ● Troubleshooting | 196 |
| ● Main Specifications | 200 |
| ● Glossary | 202 |
| ● Index | 206 |

Contents of the Operating Manual

This operating manual contains the following chapters.

1. Before Using Your Camera

Explains camera characteristics, accessories and the names of various parts.

2. Getting Started

Explains your first steps from purchasing the camera to taking pictures. Be sure to read it and follow the instructions.

3. Basic Operations

Explains the basic procedures for taking, playing back, and printing still pictures.

4. Menu Reference

Understand how to use and access the buttons and menus of the GX-1S.

5. Function Reference

Introduces functions to further enhance your GX-1S experience.

6. Software information

Explains software installation and how to use the program.

7. Appendix

Explains troubleshooting, introduces optional accessories and provides various resources.

1 Before Using Your Camera

Check the package contents and names of working parts before use.

| | |
|--|----|
| GX-1S Camera Characteristics | 10 |
| Checking the Contents of the Package | 11 |
| Names of Working Parts | 12 |

GX-1S Camera Characteristics

- Features a 23.5x15.7 mm CCD with 6.1 million effective pixels for superior definition and a wide dynamic range.
- Features an Auto-Focus sensor with 11 focusing points. The central 9 are wide cross area sensors.
- Improved manual focusing using a viewfinder similar to a conventional 35 mm SLR camera, with 0.95x magnification. Also features a superimpose function in which the focus points on the viewfinder illuminate red.
- Uses CR-V3, AA lithium batteries, rechargeable AA Ni-MH batteries or AA alkaline batteries.
- Features a large 2.5-inch LCD monitor with 210,000 pixels and a brightness adjusting function for high-precision viewing performance.
- Concepts of Universal Design have been implemented to various parts of the camera.
The large, high-resolution LCD monitor and easy-to-use menus make the camera easier to operate.

The captured area (view angle) will differ between the GX-1S and 35 mm SLR cameras even if the same lens is used because the format size for 35 mm film and the CCD are different.

Sizes for 35 mm film and CCD

35 mm film : 36x24 mm

GX-1S CCD : 23.5x15.7 mm

Angles of view being equal, the focal length of a lens used with a 35 mm camera must be approximately 1.5 times longer than that of GX-1S. To obtain a focal length framing the same area, divide the focal length of the 35 mm lens by 1.5.

Example) To capture the same image as a 150 mm lens attached to a 35 mm camera

$$150 \div 1.5 = 100$$

Use a 100 mm lens with the GX-1S.

Conversely, multiply the focal length of the lens used with GX-1S by 1.5 to determine the focal length for 35 mm cameras.

Example) If 300 mm lens is used with GX-1S

$$300 \times 1.5 = 450$$

Focal length is equivalent to 450 mm lens on a 35 mm camera.

Checking the Contents of the Package

The following accessories are packaged with your camera.
Check that all accessories are included.

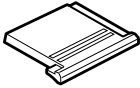

Hot shoe cover
(Installed on camera)

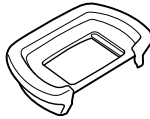

Eyecup
(Installed on camera)



Viewfinder cap

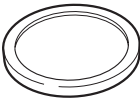

Body mount cover
(Installed on camera)

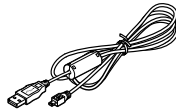

USB cable

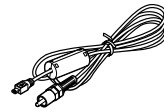

Video cable

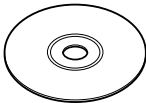

Software (CD-ROM)



Strap



AA Alkaline batteries*
(four)



Operating Manual
(this manual)

* The batteries packaged with the camera are for checking the camera's functionality.

Names of Working Parts

Camera

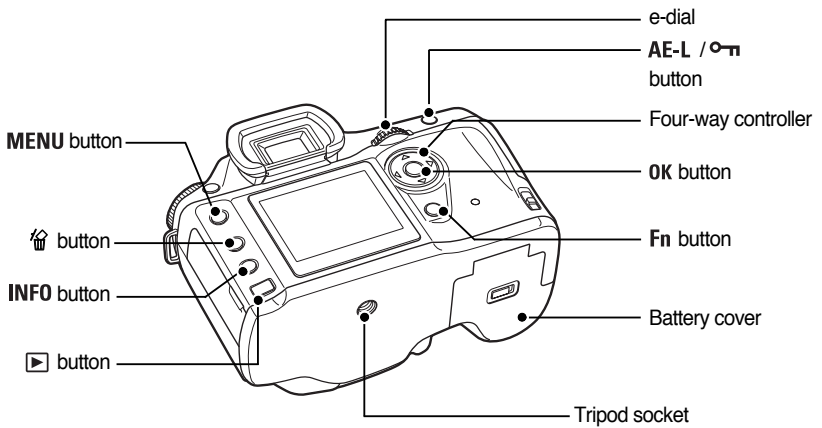
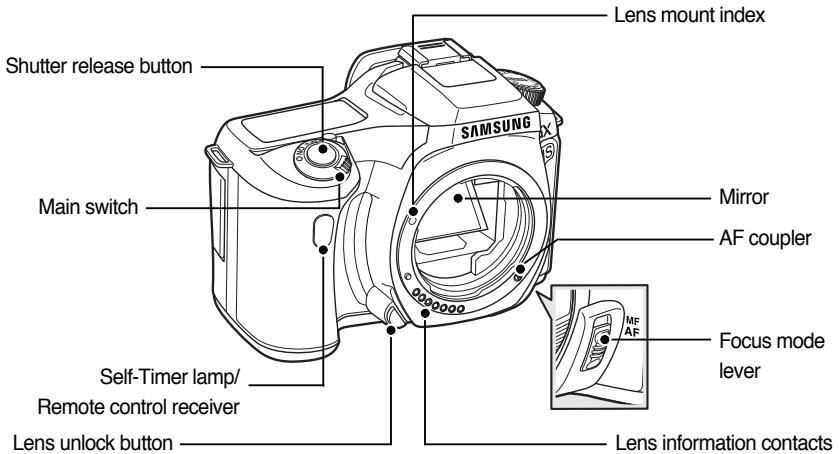

Names of Working Parts

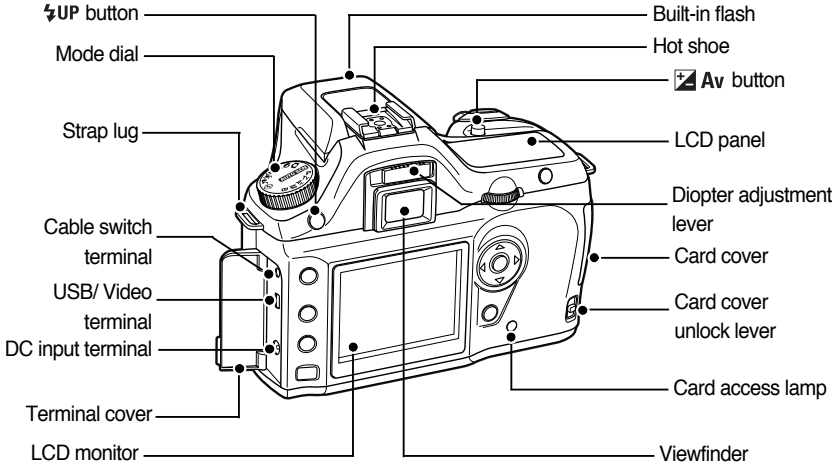

Names of Working Parts

LCD Monitor Indications

- The following indicators appear on the LCD monitor depending on the status of the camera.

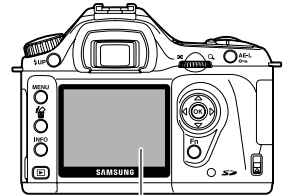

LCD monitor

While Power is On or Operating Mode Dial

- Guides appear on the LCD monitor for 3 seconds when powered on or setting dial mode.

INFORMATION

- Select [Off] for [Guide display] in [ Set-up] to not show indicators. (p.162)

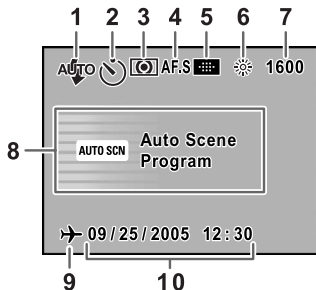

1. Flash mode (Active mode appears) (p.47)
2. Drive mode (p.100)
3. AE metering (p.129)
4. AF mode (p.119)
5. Switch focus point (p.120)
6. White balance (p.110)
7. Sensitivity (p.113)
8. Shooting mode (Mode dial position) (p.102)
9. World time warning display (p.159)
10. Date and time (p.158)

* Indicators 3,4,5,6 and 7 only appear when the setting other than the default setting is selected. 9 only appears when World Time is On ().

Names of Working Parts

Capture Mode

- Press the **INFO** button in capture mode to display the capture function settings on the LCD monitor for 15 seconds.
- Detailed Information

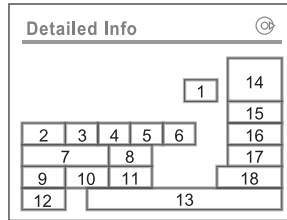
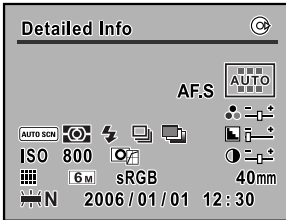

1. AF mode (p.119)
2. Shooting mode (p.102)
3. AE metering (p.129)
4. Flash mode (p.47)
5. Drive mode (p.100)
6. Auto bracket (p.142)
7. ISO sensitivity (p.113)
8. Image tone (p.106)
9. Quality level (p.108)
10. Recorded pixels (p.107)
11. Colour space (p.115)
12. White balance (p.110)
13. Date and time (p.158)
14. Focus point location (p.120)
15. Saturation (p.109)
16. Sharpness (p.109)
17. Contrast (p.109)
18. Lens focal length

- Explanation of Set Mode Dial

- Press the four-way controller (▶) to view explanation of set mode dial.

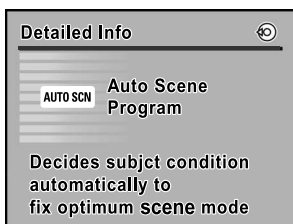

Names of Working Parts

Playback Mode

- The camera switches screen displays every time you press **INFO** button during playback.

INFORMATION

- You can change the information initially displayed by pressing the  button. (p.155)
- Detailed Information

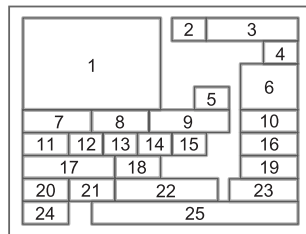
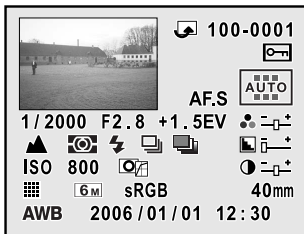

1. Captured images
2. Rotate icon (p.62)
3. Image folder number and file number (p.164)
4. Protect icon (p.75)
5. AF mode (p.119)
6. Focus point information (p.120)
7. Shutter speed (p.133)
8. Aperture (p.135)
9. EV compensation (p.140)
10. Saturation (p.109)
11. Shooting mode (p.102)
12. AE metering (p.129)
13. Flash mode (p.47)
14. Drive mode (p.100)
15. Auto bracket (p.142)
16. Sharpness (p.109)
17. ISO sensitivity (p.113)
18. Image tone (p.106)
19. Contrast (p.109)
20. Quality level (p.108)
21. Recorded pixels (p.107)
22. Colour space (p.115)
23. Lens focal length
24. White balance (p.110)
25. Captured date and time (p.158)

Names of Working Parts

- Histogram Display

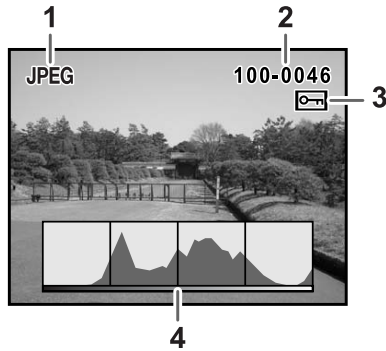

1. Capture quality (Image file type)
2. Image folder number and file number (p.164)
3. Protect icon (p.75)
4. Histogram

INFORMATION

- Areas where blooming occurred blink if [Bright Portion] warning is on.
- Press the four-way controller (▲▼) in the histogram display to move the Histogram display position up or down.

Names of Working Parts

Viewfinder Indications

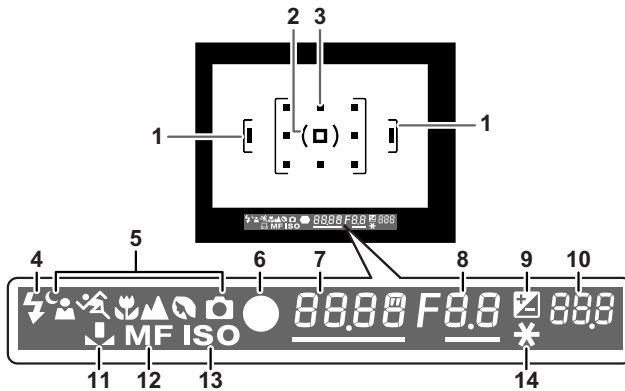

1. Autofocus frame (p.37)
2. Spot metering frame (p.129)
3. Focus point (p.120)
4. Flash status (p.47)
Appears when flash is available and blinks when flash is recommended but not set.
5. Scene mode icon (p.45)
Icon for Scene mode in use appears.
🌃 Night Scene Portrait, 🏃 Moving Object, 🌸 Macro, 🏔 Landscape, 👤 Portrait, 📷 Normal
6. Focus indicator (p.42)
Appears when image is focused.
7. Shutter speed (p.133)
Shutter speed when capturing or adjusting (underlined when shutter speed can be adjusted with e-dial).
8. Aperture (p.135)
Aperture when capturing or adjusting (underlined when aperture can be adjusted with e-dial).
9. EV compensation (p.140)
Appears when EV compensation is available or in use.
Blinks slowly when compensating flash output.
Blinks quickly when compensating exposure and flash output.
Adjusted value appears where number of recordable images is shown.

Names of Working Parts

10. Number of recordable images/ EV compensation
 - Show the number of recordable images with current quality and recorded pixel setting.
 - Show the number of continuous shooting recordable images. (p.98)
 - EV compensation value appears when EV compensation is being adjusted. (p.132)
 - The difference with the appropriate exposure value appears if exposure mode is **M**. (p.137)
11. Manual white balance (p.111)
 - Appears when manual white balance is in use and blinks while adjusting.
12. Manual focus (p.124)
 - Appears when focus mode is **MF**.
13. ISO sensitivity warning (p.114)
 - Appears when warning value is exceeded.
14. AE lock indicator (p.141)
 - Appears during AE lock.

INFORMATION

- The red indication of the focus point used for autofocus lights up and is superimposed on the view when the shutter release button is pressed halfway.

Names of Working Parts

LCD Panel Indications

- The following information appears in the LCD panel on top of the camera.

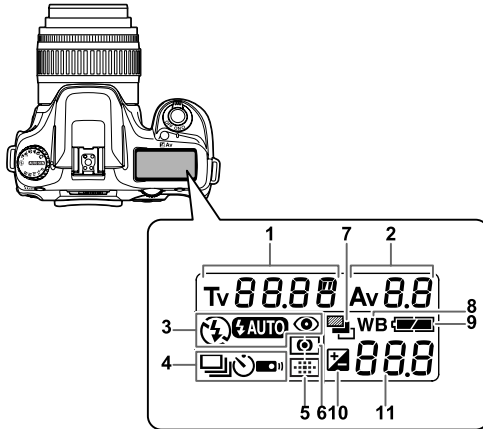

1. Shutter speed (p.133)

2. Aperture (p.135)

3. Flash mode (p.47)

 : Built-in flash is ready
(when blinking, flash should be used)

 : Flash off

 : Auto discharge

 : Red-eye reduction flash on

4. Drive mode (p.100)

 : Single frame shooting

 : Continuous shooting

 : Self-Timer shooting

 : Remote control shooting

5. Focus point information (p.120)

No indicator : Auto

 : Select

 : Centre

6. AE metering (p.129)

No indicator : Multi-segment metering

 : Center-weighted metering

 : Spot metering

7. Auto bracketing (p.142)

8. White balance (p.110)

(Not displayed when set to Auto)

9. Battery level (p.25)

10. EV compensation (p.140)

11. Number of recordable images/
EV compensation value/ PC (Pb)
(PC=Personal Computer (mass storage),
Pb=PictBridge)

2 Getting Started

This chapter explains your first steps from purchasing the camera to taking pictures. Be sure to read it and follow the instructions.

| | |
|--|----|
| Attaching the Strap | 22 |
| Connecting to a Power Source | 23 |
| Using the memory card | 27 |
| Turning the Camera On and Off | 30 |
| Initial Settings | 31 |
| Attaching the Lens | 35 |
| Adjusting the Viewfinder Diopter | 37 |

Attaching the Strap

1. Pass the end of the strap through the strap lug, then secure on the inside of the clasp.

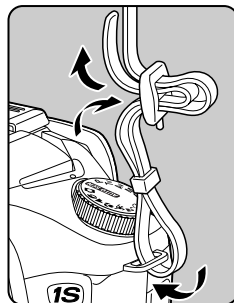

2. Pass the other end of the strap through the other strap lug on the camera, then secure on the inside of the clasp.

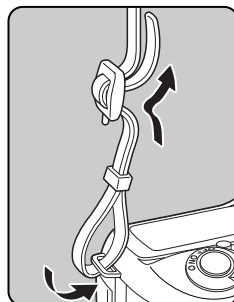

Connecting to a Power Source

Inserting the Batteries

- Insert batteries into the camera. Use two CR-V3 or four AA Ni-MH batteries, AA lithium batteries, or AA alkaline batteries.

This camera is packaged with AA alkaline batteries for checking the camera's functionality but some other kinds of batteries are also compatible. Refer to "Batteries" (p.24) for details on compatible batteries and when to use them.

INFORMATION

- CR-V3, AA lithium batteries and AA alkaline batteries are not rechargeable.
- Do not open the battery cover or remove the batteries while the power is on.
- Remove the batteries when you will not use the camera for a long while. The batteries may leak.
- If the date and time settings have been reset when you insert new batteries after a long while, follow the procedure for "Setting the Date and Time".
- Insert batteries correctly. Batteries inserted incorrectly may cause a camera breakdown. Wipe the electrodes of the batteries before inserting.
- Replace all the batteries at the same time. Do not mix battery type, brands or an old battery with a new one.

1. Push and hold the battery cover unlock lever as shown in the illustration (①), and slide the battery cover toward the lens (②), and then flip open.

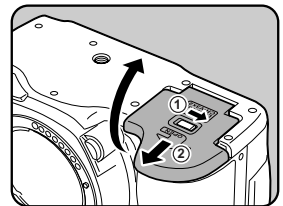

2. Insert the batteries according to the + / - indicators in the battery chamber.

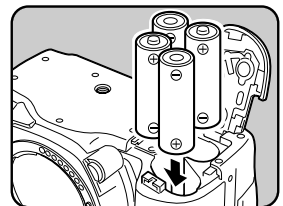

Connecting to a Power Source

3. Press down on the batteries with the battery cover (①) and slide it as shown in the illustration (②) to close.

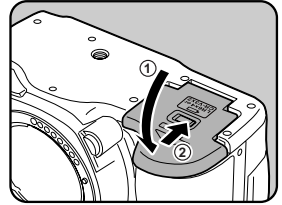

INFORMATION

- Check the battery orientation if the camera does not operate properly after replacing the batteries.

Batteries

- You can use four kinds of batteries with your camera. Battery performance differs by type. Please choose the type that best suits your purpose.

| | |
|---------------------------------|--|
| CR-V3 | The CR-V3 is a long-life battery and is convenient when travelling. |
| AA Ni-MH rechargeable batteries | These are rechargeable and are economical. |
| AA lithium batteries | Recommended in cold climates. |
| AA alkaline batteries | Provided with the camera. These are easily obtainable when your usual batteries run out but they may not support all the camera functions under certain conditions. We do not recommend their use except in emergencies and checking the camera's functionality. |





INFORMATION

- Oxide batteries and rechargeable CR-V3 batteries may cause malfunctions due to their voltage characteristics so their use is not recommended.

Connecting to a Power Source

Battery Level Indicator

- You can confirm remaining battery level by checking the  displayed on the LCD panel.

| | | |
|---|-------|--|
|  | lit | : Battery is full. |
| ↓ | | |
|  | lit | : Battery is running low. |
| ↓ | | |
|  | lit | : Battery is almost empty. |
| ↓ | | |
|  | blink | : The camera turns off after displaying a message. |

Approximate Playback Time (new batteries)

| Batteries | Normal recording | Flash photography | | Playback time |
|----------------------------------|------------------|-------------------|-------------|---------------|
| | | 50% use | 100% use | |
| CR-V3 | 1,650 minutes | 1,200 minutes | 690 minutes | 1,030 minutes |
| AA rechargeable batteries (NiMH) | 1,020 minutes | 650 minutes | 530 minutes | 630 minutes |
| AA Alkaline Batteries | 320 minutes | 250 minutes | 150 minutes | 500 minutes |

- The still picture storage capacity is based on measuring conditions in accordance with CIPA standards and the playback time is based on SAMSUNG measuring conditions. Some deviation from the above figures may occur in actual use depending on shooting mode and shooting conditions.

INFORMATION

- Battery performance temporarily decreases as the temperature decreases. When using the camera in cold climates, have extra batteries on hand and keep them warm in your pocket. Battery performance will return to normal when returned to room temperature.
- AA alkaline batteries may not support all the camera functions. We do not recommend their use except in emergencies and checking the camera's functionality.
- Have extra batteries ready when travelling overseas, taking pictures in cold climates, or when you will be taking a lot of pictures.

Connecting to a Power Source

Using the AC Adapter (Optional)

- AC adapter (D-AC10, optional) for PENTAX DSLR camera can be used with SAMSUNG DSLR camera.

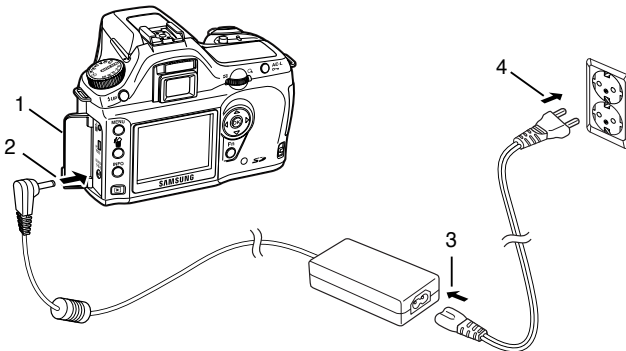

- We recommend using the AC adapter D-AC10 (optional) when using the LCD monitor for a long time or when connecting to your PC.

1. Make sure the camera is turned off before opening the terminal cover.
2. Connect the DC terminal on the AC adapter to the DC input terminal on the camera.
3. Connect the AC plug cord to the AC adapter.
4. Plug the AC cord into the power outlet.

INFORMATION

- Make sure the camera is turned off before connecting or disconnecting the AC adapter.
- Make sure connections are secure between the camera, AC adapter, AC plug cord terminal and the power outlet. SD Memory Card and data will be corrupted if disconnected while camera is recording or reading data.
- Be sure to read the AC adapter D-AC10 operating manual when using the AC adapter.
- The rechargeable batteries in your camera will not charge when connected to the AC adapter.

Using the memory card

Inserting/ Removing the SD Memory Card

- Captured images are recorded on the SD Memory Card. Make sure the camera is turned off before inserting or removing the SD Memory Card.

INFORMATION

- Do not remove the SD Memory Card while card access lamp is lit.
- Always format new SD Memory Cards before use. Also format SD Memory Cards used with other cameras. Refer to “Formatting the SD Memory Card” (p.157) for details on formatting.

1. Press the card cover unlock lever in the indicated direction.
Card cover opens.

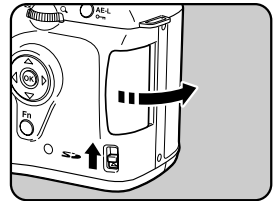

2. Insert the card all the way with the SD Memory Card label toward the LCD monitor.

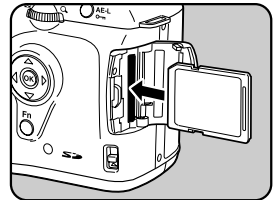

3. Close the card cover.

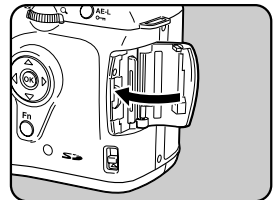

Using the memory card

4. Push the SD Memory Card in once to remove.

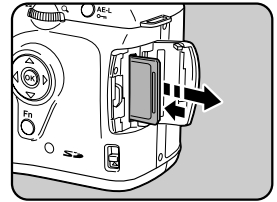

Precautions When Using the SD Memory Card

- The SD Memory Card is equipped with a write-protect switch. Setting the switch to LOCK protects the existing data by prohibiting recording of new data, deletion of existing data or formatting of the card.
- Care should be taken when removing the SD Memory Card immediately after using the camera because the card may be hot.
- Do not remove the SD Memory Card or turn the camera off while data is being saved to the card, images are being played back, or the camera is connected to a computer with the USB cable. This may cause the data to be lost or the card to be damaged.
- Do not bend the SD Memory Card or subject it to violent impact. Keep it away from water and store away from high temperatures.
- Do not remove the SD Memory Card during formatting. The card may be damaged beyond use.
- Data on the SD Memory Card may be deleted in the following circumstances.
Samsung Camera does not accept any liability for data that is deleted if
 - (1) the SD Memory Card is mishandled by the user.
 - (2) the SD Memory Card is exposed to static electricity or electrical interference.
 - (3) the card has not been used for a long time.
 - (4) the card is ejected or the battery is removed while the data on the card is being recorded or accessed.
- The SD Memory Card has a limited service life. If it is not used for a long time, the data on the card may become unreadable. Be sure to regularly make a backup of important data on a computer.
- Avoid using or storing the card where it may be exposed to static electricity or electrical interference.
- Avoid using or storing the card in direct sunlight or where it may be exposed to rapid changes in temperature or to condensation.
- For information on compatible SD Memory Cards, visit the Samsung Camera website or contact your nearest Samsung Camera customer service center.
- Always format new SD Memory Cards. Also format SD Memory Cards used with other cameras.
 - ☞ Formatting the SD Memory Card (p.157)

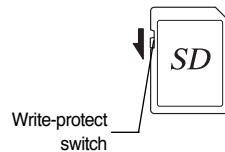

Using the memory card

Recorded Pixels and Quality Level

- Choose the number of pixels (size) and quality level (data compression rate) of pictures according to how you intend to use the pictures you have taken.

Pictures with larger recorded size or the more  are clearer when printed.

The number of pictures that can be taken (the number of pictures that can be recorded on an SD Memory Card) becomes less with larger file sizes.







The quality of the captured photo or printed picture depends on the quality level, exposure control, resolution of the printer and a variety of other factors so you do not need to select more than the required number of pixels. For example, to print in postcard size,  (1536 × 1024) is adequate. Set the appropriate recorded size and quality level depending on purpose.

Choose the appropriate number of recorded pixels and quality level for images on the [ Rec. Mode] menu.

 Setting the Recorded Pixels (p.107)

 Setting the Quality Level (p.108)

● Recorded Pixels, Quality Level and Approximate Image Storage Capacity

| Recorded Pixels | Quality Level | RAW |  Best |  Better |  Good |
|--|---------------|-----|--|--|--|
| | | | | | |
|  | (3008x2008) | 10 | - | - | - |
| | (3008x2000) | - | 33 | 68 | 114 |
|  | (2400x1600) | - | 50 | 94 | 158 |
|  | (1536x1024) | - | 103 | 169 | 266 |

- The above table shows the approximate image storage capacity and recording time when using a 128 MB SD Memory Card.
- The above figures may vary depending on the subject, shooting conditions, shooting mode, SD Memory Card and other factors.

Turning the Camera On and Off

- Move the main switch to [ON] position.
The camera will turn on.
Move the main switch to [OFF] position to turn off the camera.

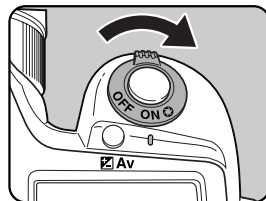

INFORMATION

- Always turn the camera off when not in use.
- The power will automatically turn off when you do not perform any operations within a set period of time. (Default setting is 1 minute) (p.164)

Initial Settings

- The first time the camera is turned on after purchasing, the “Initial Settings” screen appears on the LCD monitor. Follow the procedure below to set the language displayed on the LCD monitor and the current date and time.

Once setting is done, these will not need to be set again when turning your camera on.

Setting the Display Language

- You can choose the language in which the menus, error messages, etc. are displayed from the following: English, French, German, Spanish, Italian, Swedish, Dutch, Russian, Korean, Chinese (traditional/ simplified) and Portuguese.

1. Press the four-way controller (▶).

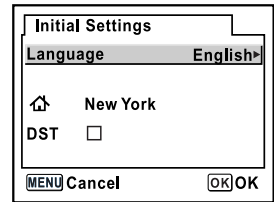

2. Use the four-way controller (▲▼◀▶) to select your applicable language.

The default setting is English.

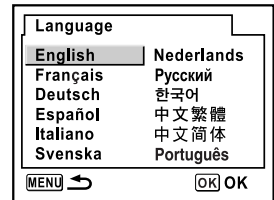

3. Press the **OK** button.

Initial Settings

4. Press the four-way controller (▼).

The cursor moves to [🏠].

5. Press the four-way controller (◀▶) to select the city.

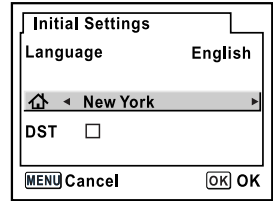

6. Press the four-way controller (▼).

The cursor moves to DST (daylight saving time).

7. Use the four-way controller (◀▶) to select (On) or (Off).

8. Press the **OK** button.

The screen for setting the date and time will be displayed.

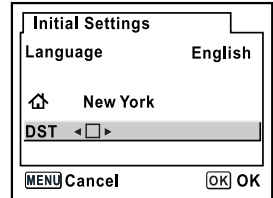

When an Incorrect Language is Set

Follow the procedure below to display the screen for setting the language, and go to Step 2 on p.31 to set the language again.

1. Turn the camera off and turn it on again.
2. Press the **MENU** button.
3. Press the four-way controller (▶) twice.
4. Press the four-way controller (▼) five times.
5. Press the four-way controller (▶) once.

The screen for setting the language will be displayed.

Initial Settings

Setting the Date and Time

- Set the current date and time and the display style.

1. Press the four-way controller (▶).
The frame moves to [mm/dd/yy].
2. Use the four-way controller (▲▼) to choose the date style.

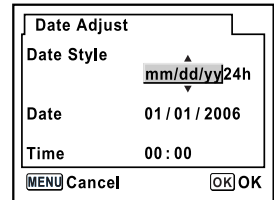

3. Press the four-way controller (▶).
The frame moves to [24h].
4. Use the four-way controller (▲▼) to select 24h (24 hour display) or 12h (12-hour display).
5. Press the four-way controller (▶).
The frame returns to [Date Style].
6. Press the four-way controller (▼).
The frame moves to [Date].

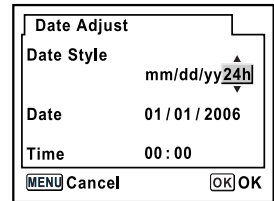

Initial Settings

7. Press the four-way controller (▶).
The frame moves to the month.

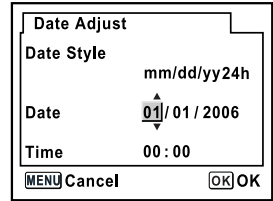

8. Use the four-way controller (▲▼) to set the month.
Set the day and year in the same manner.
Next, set the time.
If you select [12h] in Step 4, the setting switches between am and pm depending on the time.
9. Press the **OK** button.
The camera is ready to take pictures. If you set the date and time with the menu operations, the screen will return to the [X ↓ Set-up] menu.
Press the **OK** button again.

INFORMATION

- You can cancel the setting operation and switch to Capture mode during initial settings by pressing the **MENU** button. In this case, the Initial Settings screen will appear again the next time you turn the camera on.
- When you finish the settings and press the **OK** button, the camera clock is reset to 00 seconds. To set the exact time, press the **OK** button when the time signal (on the TV, radio, etc.) reaches 00 seconds.
- You can change the language and date and time settings with the menu operations. (p.158, p.162)

Attaching the Lens

- Only D-XENON lenses can be used with this camera.

INFORMATION

- Turn the camera off before attaching or removing the lens to prevent unexpected lens.

1. Check that the camera is off.
2. Remove the body mount cover (①) and lens mount cover (②).
Be sure to put the lens down with the lens mount side facing upward to damage.

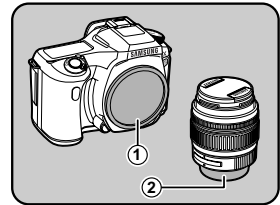

3. Align the red dots on the camera and the lens, and secure by turning the lens clockwise until it clicks.
After attaching, check that the lens is secure. Also check that the red dots of the lens are on top and attachment portion does not move sideways.

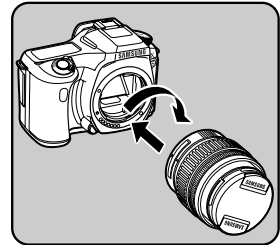

Attaching the Lens

4. Remove the front lens cap by pushing the indicated portions inward.

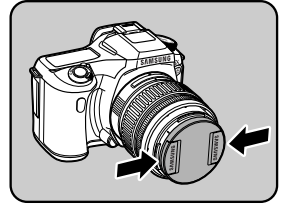

- To detach the lens, hold down the lens unlock button (③) and turn the lens counterclockwise.

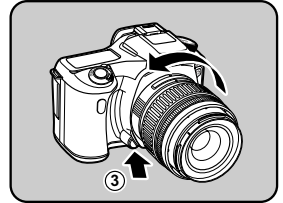

INFORMATION

- The body mount cover (①) is a cover to prevent damage during shipping.
- We assume no responsibility nor liability for accidents, damages and malfunctions resulting from the use of lenses made by other manufacturers.
- The camera body and lens mount incorporate lens information contacts and an AF coupler. Dirt, dust, or corrosion may damage the electrical system. Clean the contacts with a soft dry cloth.

Adjusting the Viewfinder Diopter

- Adjust the viewfinder to suit your eyesight.

If it is difficult to see the viewfinder image clearly, slide the diopter adjustment lever sideways.

You can slide the diopter from -2.5m^{-1} to $+1.5\text{m}^{-1}$.

1. Look through the viewfinder and point the camera at a well-lit scene. Slide the diopter adjustment lever left or right. Adjust the lever until the AF frame in the viewfinder is focused.

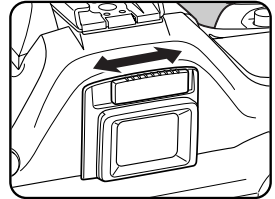

AF Frame

INFORMATION

- Eyecup is attached to the viewfinder portion when camera leaves the factory. Diopter adjustment is available with the eyecup attached. However, adjustment is easier with the eyecup removed as shown above. To remove the eyecup, pull upward and remove as shown on the right.
- If it is difficult to see the viewfinder image clearly even if you set the diopter adjustment lever, use the diopter correction lens adapter (optional). However, the eyecup must be removed.

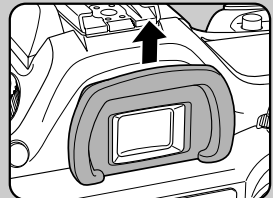

MEMO

A large, empty rectangular box with rounded corners, intended for writing a memo. The box is outlined in a thin grey line and occupies most of the page below the header.

3 Basic Operations

This chapter explains basic operations for shooting by setting mode dial to Scene mode (Auto Scene or Normal mode - Flash OFF mode) to ensure success.

For information about advanced functions and settings for taking pictures, refer to chapter 4 and onward.

| | |
|---|----|
| Basic Shooting Operation | 40 |
| Selecting the Appropriate Capturing Mode for Scenes | 45 |
| Using the Zoom Lens | 46 |
| Using the Built-in Flash | 47 |
| Other Shooting Modes | 51 |
| Playing Back Still Pictures | 61 |
| Connecting the Camera to AV Equipment..... | 68 |
| Processing Images with Filters | 69 |
| Deleting Images | 71 |
| Protecting Images | 75 |
| Setting the Printing Service (DPOF) | 77 |
| Printing Using PictBridge | 81 |

Basic Shooting Operation

Holding the Camera

- How you hold the camera is important when taking pictures.
 - Hold the camera firmly with both hands.
 - Press the shutter release button gently when taking a picture.

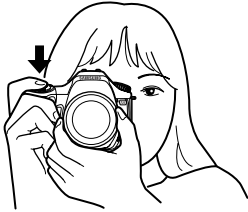

[Horizontal position]



[Vertical position]

INFORMATION

- To reduce camera shake, support your body or the camera on a solid object such as a table, tree, or wall. Always use the shortest practical shutter speed for hand-held shots, especially when using Zoom or Telephoto lenses.
- Although there are individual differences among photographers, the slowest recommended shutter speed for a handheld camera is generally $1/(\text{focal length} \times 1.5)$. For example, it is $1/75$ of a second for a focal length of 50 mm and $1/150$ of a second for 100 mm. A tripod should be used for shutter speeds slower than this.
- When using a telephoto lens, a tripod that is heavier than the total weight of the camera and lens is recommended to avoid camera shake.

Basic Shooting Operation

Letting the Camera Choose the Optimal Settings

- How to set the camera so it will choose the optimum settings based on the subject lighting, distance and motion.

1. Set the mode dial to **AUTO SCN** .

The camera will select the optimal capturing mode for the subject.

- Selecting the Appropriate Capturing Mode for Scenes (p.45)

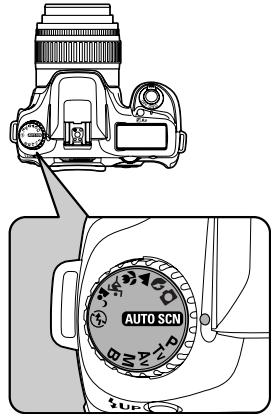

2. Set the focus mode lever to **AF** .

Autofocus mode is set. (p.116)

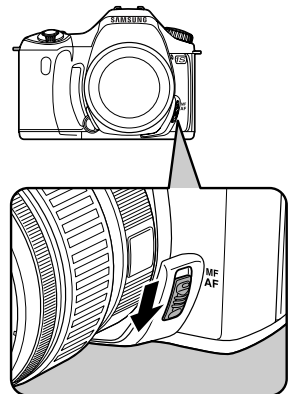

Basic Shooting Operation

3. Turn the zoom ring to select the size of the subject.
 - Using the Zoom Lens (p.46)

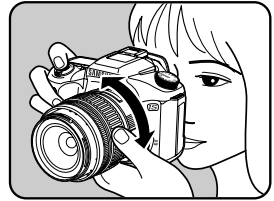

4. Position the subject inside the autofocus frame and press the shutter release button halfway.

The autofocus system operates.

The focus indicator ● appears in the viewfinder when the subject is in focus.

The flash pops up automatically when necessary (manually lift the flash when Flash mode is not set to [Auto]).

 - Operating the shutter release button (p.43)
 - Hard-to-Autofocus Subjects (p.44)
 - Using the Built-in Flash (p.47)



Focus indicator

5. Press the shutter release button fully.

The picture is taken.



Basic Shooting Operation

6. Review captured images on the LCD monitor.

Image displays for 1 second on the LCD monitor after capturing (Instant Review.)

You can delete the image during Instant Review by pressing the  button.

- Setting the Display Time (p.165)
- Deleting Images (p.71)
- Displaying Bright Portion Warning (p.155)

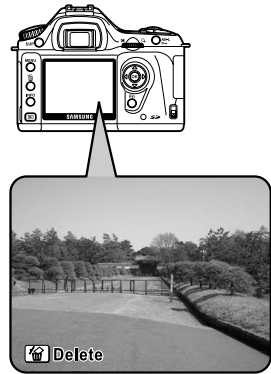

Operating the shutter release button

- The shutter release button has two positions.

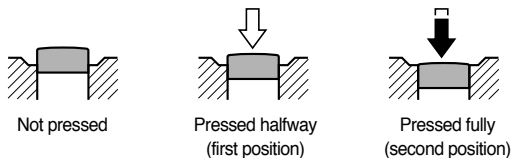

Pressing it down halfway (first position) turns on the viewfinder and LCD panel indicators and the autofocus system operates. Pressing it fully (second position) takes the picture.

INFORMATION

- Squeeze the shutter release button gently when taking a picture to prevent camera shake.
- Practice pressing the shutter release button halfway to learn where the first position is.
- The viewfinder indicators stay on while shutter release button is pressed. The indications stay on for about 10 seconds (default setting) after the button is released.

Basic Shooting Operation

Hard-to-Autofocus Subjects

- The autofocus mechanism is not perfect. Focusing may be difficult when taking pictures under the following conditions ((a) to (f) below). These also apply to manual focusing using the focus indicator ● in the viewfinder. If the subject cannot be focused automatically, set the focus mode lever to **MF** and use the manual focus mode to focus on the subject with the aid of the matte field in the viewfinder.
 - (a) Extremely low-contrast subjects such as a white wall in the focus points range.
 - (b) Subjects which do not reflect much light within the focus points range.
 - (c) Fast moving objects.
 - (d) Strongly reflected light or strong backlighting (bright background).
 - (e) If vertical or horizontal line patterns appear within the focus points range.
 - (f) Multiple subjects in the foreground and background within the focus points range.

INFORMATION

- Subject may not be focused even when ● (focus indicator) is displayed when (f) above applies.

Selecting the Appropriate Capturing Mode for Scenes

- The camera selects and sets the optimum mode when **AUTO SCN** (Auto Scene) is set on the dial indicator.

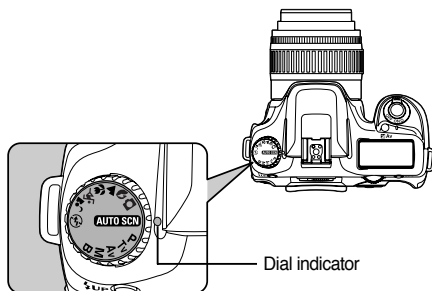

Select (Normal), (Portrait), (Landscape), (Macro), (Moving Object), (Night Scene Portrait), (Flash OFF) with the mode dial if desired image is not captured in Auto Scene mode. The modes are as follows.

| | |
|------------------------------|---|
| AUTO SCN (Auto Scene) | Selects automatically from Normal, Portrait, Landscape, Macro, and Moving Object modes. |
| (Normal) | The basic picture-taking mode. |
| (Portrait) | Optimal for capturing portraits. |
| (Landscape) | Deepens the focus range, emphasizes contour and saturation of trees and the sky, and produces a bright image. |
| (Macro) | Lets you take vibrant pictures of flowers and other small subjects at short distances. |
| (Moving Object) | Lets you take sharp pictures of a quickly moving subject, such as at a sporting event. |
| (Night Scene Portrait) | Lets you capture people against a night view or dusk. |
| (Flash OFF) | The built-in flash is deactivated. Other settings are the same as (Normal). |

INFORMATION

- For (Night Scene Portrait), the shutter speed becomes slower in dark places, even if the built-in flash is used. Use a tripod to avoid camera shake.

Using the Zoom Lens

- Enlarge the subject (telephoto) or capture a wider area (wide angle) with a zoom lens. Adjust it to the desired size and take the picture.

1. Turn the zoom ring to the right or left.
Turn the zoom ring clockwise for telephoto and counterclockwise for wide angle.



INFORMATION

- The smaller the number of the displayed focal length, the wider the angle.
The larger the number, the more magnified the image appears.
- Power Zoom functions (Image Size Tracking, Zoom Clip, and Auto Zoom Effect) are not compatible with this camera.

Wide Angle

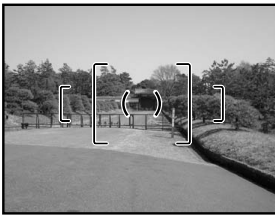

Telephoto

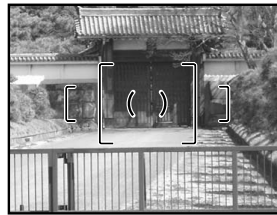

Using the Built-in Flash

- Use the following procedures to take a picture in low light or backlit conditions or when you want to manually use the built-in flash.

The built-in flash gives best results within a range of 0.7 m to 4 m from the subject.





Exposure will not be properly controlled and vignetting may occur when used at a distance closer than 0.7 m (this distance varies slightly depending on the lens being used and set sensitivity).

- ※ Compatibility of built-in flash and lens

Vignetting (darkening of the corners of the image due to a lack of light) may occur depending on the lens being used and the capture conditions. We recommend taking a test shot to confirm this.

INFORMATION

- When using the built-in flash, remove the lens hood before shooting.

| | |
|--|---|
|  Auto discharge | Camera automatically determines surrounding light and built-in flash pops up and discharges automatically when necessary (flash does not discharge even if it is popped up when not necessary). |
|  Manual discharge | Discharges flash manually. Flash discharges when popped up, does not discharge when retracted. |
|  Auto flash+Redeye reduct | Lights a red-eye reduction light before automatic flash. |
|  Manual flash+Redeye reduct | Discharges flash manually. Lights a red-eye reduction light before manual flash. |

INFORMATION

- Manual discharge mode (Flash ON) is used regardless of flash mode settings if the  button is pressed to pop up the flash manually.

Using the Built-in Flash

Selecting Flash Mode

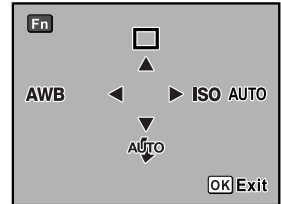

1. Press the **Fn** button.
The Fn menu appears.

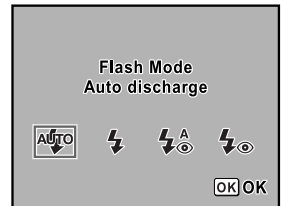

2. Press the four-way controller (▼).
The flash options screen appears.







INFORMATION

- When the mode dial is set to **P**, **Tv**, **Av**, **M** or **B**,  and  appear grey and cannot be selected.

3. Use the four-way controller (◀▶) to choose a flash mode.
4. Press the **OK** button twice.
The camera is ready to take a picture.

Using Auto Discharge , (Automatic Flash Pop-up)

1. Set the mode dial to **AUTO/SCN**, , , , or .
2. Press the shutter release button halfway.
The built-in flash pops up if necessary and begins charging.
When the flash is fully charged,  appears in the LCD panel and viewfinder. (p.14 ~ p.20)

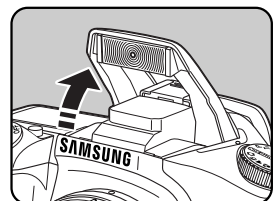

Using the Built-in Flash

INFORMATION

- Switch between Auto discharge mode and Manual discharge mode (Flash ON) by pressing the **UP** button while the built-in flash is popped up.
If Auto discharge is set, **AUTO** appears on the LCD panel.

3. Press the shutter release button fully. The picture is taken.
4. Push down on the portion indicated in the illustration to retract the flash.

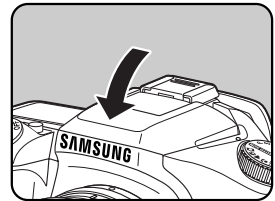

Using Manual Discharge (Flash ON) **UP**, **UP**

1. Press the **UP** button.
The built-in flash pops up and begins charging.
Manual discharge mode (Flash ON) is used regardless of flash mode settings. When the flash is fully charged, **UP** appears in the LCD panel and viewfinder.

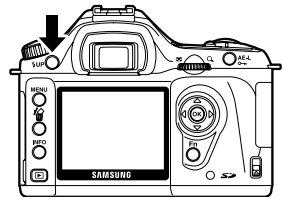

INFORMATION

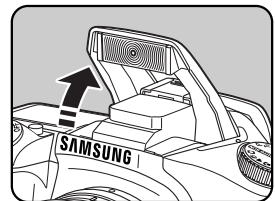

- Switch between Auto discharge mode and Manual discharge mode by pressing the **UP** button while the built-in flash is popped up when shooting mode is set to **(AUTO SCN)**, **□**, **📷**, **▲**, **🌸**, **🏠**, or **👤**.



2. Press the shutter release button fully. The flash discharges and the picture is taken.
3. Push the flash down to retract.

Using the Built-in Flash

Using Red-eye Reduction Flash

- “Red-eye” is the phenomenon where eyes look reddish in photographs taken in dark environments with a flash. This is caused by the reflection of the electronic flash from the retina of the eye. Red-eye occurs because pupils are dilated in dark environments. This phenomenon cannot be averted but the following measures can be used to combat it.
 - Brighten the surroundings when shooting.
 - If using a zoom lens, set it to wide-angle and move in closer to your subject.
 - Use a flash that supports red-eye reduction.
 - Position the flash as far away from the camera as possible when using an external flash.The red-eye reduction function on this camera reduces red-eye by discharging the flash twice. With the red-eye reduction function, the pre-flash is discharged just before the shutter is released. This reduces pupil dilation. The main flash is then discharged while the pupils are smaller, reducing the red-eye effect. To use the red-eye reduction function, set  (Red-eye reduction auto flash) in Picture mode or  (Red-eye reduction manual flash) in other modes.

Daylight-Sync Shooting

- In daylight conditions, the flash will eliminate shadows when a portrait picture is taken with a person's face cast in shadow. Use of the flash in this way is called Daylight-Sync Shooting. Flash is discharged manually when shooting with Daylight-Sync Shooting.
- Taking pictures (Auto Scene)
 1. Confirm that the flash has popped up and the flash mode is set to  (Manual discharge). (p.49)
 2. Confirm that the flash is fully charged.
 3. Take the picture.
- ※ The picture may be over-exposed if the background is too bright.



[Without Daylight-Sync]



[With Daylight-Sync]

Other Shooting Modes

Continuous Shooting

- Pictures can be taken continuously while the shutter release button is held down.

1. Press the **Fn** button.

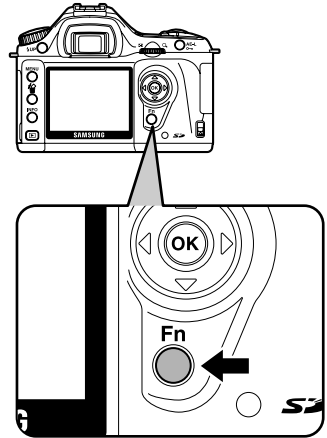

The Fn menu appears.

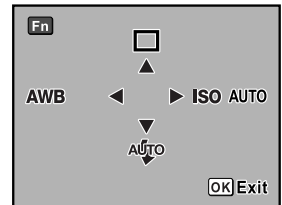

Other Shooting Modes

2. Press the four-way controller (▲).

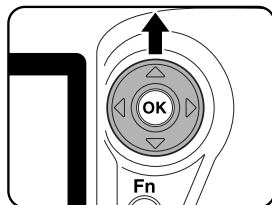

The Drive Mode options screen appears.

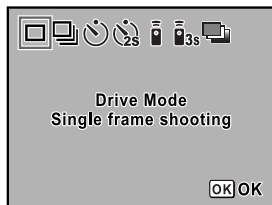

3. Use the four-way controller (◀▶) to select  .

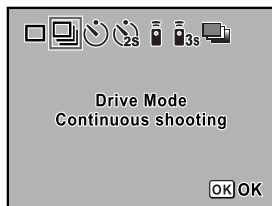

4. Press the **OK** button twice.
The camera is ready to take pictures.

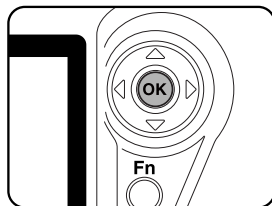

5. Press the shutter release button halfway.
The autofocus system operates. The focus indicator ● appears in the viewfinder when the subject is in focus.

Other Shooting Modes

※ Set [No. cnt shtng rcd im] in [Recordable Image No.] of the [**C** Custom Setting] menu.

The number of continuously recordable images (buffer space) appears when shutter is pressed halfway. (p.98)

6. Press the shutter release button fully.

Pictures are taken continuously while the shutter release button is fully pressed. Take your finger off the shutter release button to stop.



Continuous shooting settings are retained when the power is turned off.



Display the Fn menu again and set to (Single frame shooting) to stop Continuous shooting.

INFORMATION

- The focus is adjusted each time the shutter is released if the focus mode is set to **AF.S** (Single mode). (p.119)
- Focusing is continuously active when the mode dial is set to **P**, **Tv**, **Av** or **M** and focus mode is set to **AF.C** (Continuous mode), or when Picture mode is set to  (Moving Object).
Note that the shutter will release even if the focusing is not complete.
- The shutter cannot be released until charging is complete when using the built-in flash. Use a custom function to enable shutter release before the built-in flash is ready.

Self-Timer Shooting

- This camera has two types of self-timers:  and .

| | |
|---|--|
|  | Shutter will be released after about 12 seconds. Use this mode to include the photographer in the picture. |
|  | Shutter is released after about 2 seconds. Use this mode to avoid camera shake when the shutter release button is pressed. |

1. Mount the camera to a tripod.

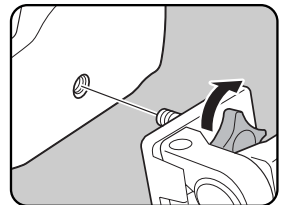

Other Shooting Modes

2. Press the Fn button.

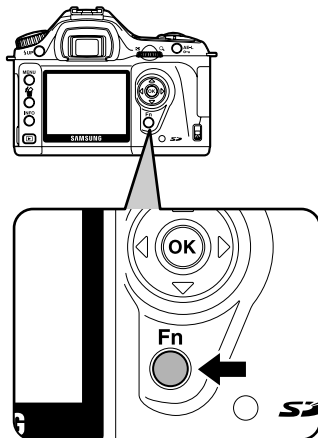

The Fn menu appears.

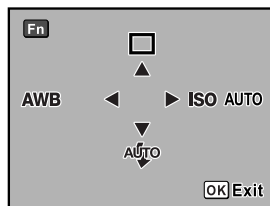

3. Press the four-way controller (▲).

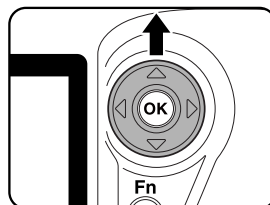

Other Shooting Modes

The Drive Mode options screen appears.

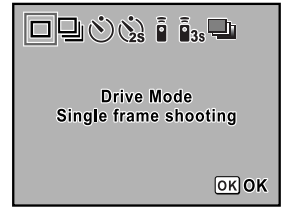

4. Use the four-way controller (◀▶) to select ⌚ or ⌚_{2s}.

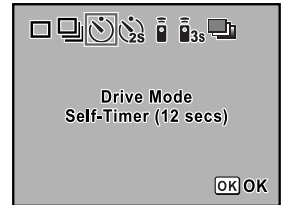

5. Press the **OK** button twice.
The camera is ready to take pictures.

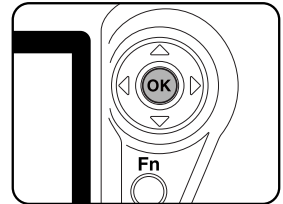

6. Confirm in the viewfinder that the subject you wish to shoot is in the display and press the shutter release button halfway.
The focus indicator ● appears when the subject is in focus.



Other Shooting Modes

7. Press the shutter release button fully.

For , the self-timer lamp starts blinking slowly and blinks rapidly 2 seconds before the shutter is released.

The beep is heard and the rate increases.

The shutter will be released about 12 seconds after the shutter release button is pressed fully.

For , the shutter will be released about 2 seconds after the shutter release button is pressed fully.

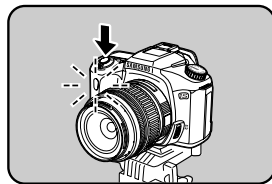



8. Turn the camera off after shooting.

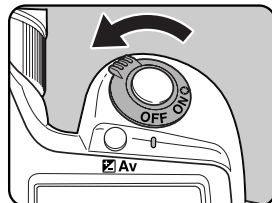

The next time the power is turned on, self-timer shooting is cancelled and returns to single frame shooting.



Other Shooting Modes

Remote Control Shooting (Remote Control F: Sold Separately)

- Remote Control for PENTAX DSLR can be used with SAMSUNG DSLR.
- The shutter can be released with the optional remote control unit. You can select from  (remote control) and  (three-second delay) for remote control shooting.

| | |
|---|--|
|  | The shutter will be released immediately after the shutter release button on the remote control unit is pressed. |
|  | The shutter will be released 3 seconds after the shutter release button on the remote control unit is pressed. |

1. Mount the camera to a tripod.

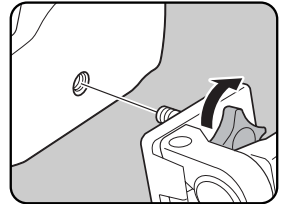

2. Press the **Fn** button.

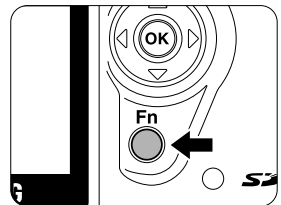

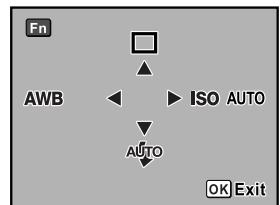

The Fn menu appears.

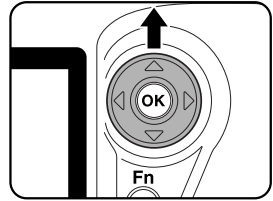

Other Shooting Modes

3. Press the four-way controller (▲).
The Drive Mode options screen appears.



4. Use the four-way controller (◀▶) to select  or .
The self-timer lamp will blink to let you know that the camera is in remote control wait status.

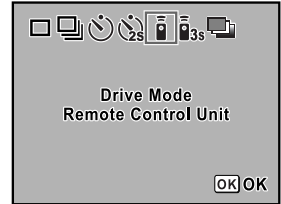

5. Press the **OK** button twice.
The camera is ready to take pictures.
6. Press the shutter release button halfway.
The autofocus system operates. The focus indicator ● appears in the viewfinder when the subject is in focus.

INFORMATION

- You cannot focus with the remote control unit in default settings. Focus on the subject first before operating with the remote control. You can set [AF in remote control] to [On] in the custom function. (p.98)
- When using the Remote Control Unit, flash does not pop up automatically even when set to  (Auto discharge). Pop up the flash manually beforehand. (p.49)

Other Shooting Modes

7. Point the remote control unit towards the front of the camera and press the shutter release button on the remote control. The operating distance of the remote control unit is about 5 m from the front of the camera. The shutter will be released immediately or approximately 3 seconds after the shutter release button on the remote control unit is pressed depending on the drive mode selected. When the picture is taken, the self-timer lamp lights for 2 seconds and will then resume blinking.

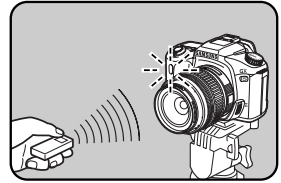

INFORMATION

- Exposure may be affected if light enters the viewfinder. Attach the provided viewfinder cap or use the AE lock function (p.141) (ignore the light entering the viewfinder when the exposure mode is set to a (manual) (p.137)).
- Remove the Eyecup by pulling one side out and toward you when using accessories such as the viewfinder cap.

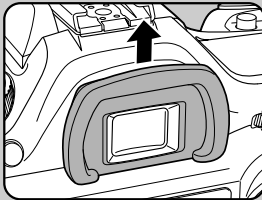

[Removing the Eyecup]

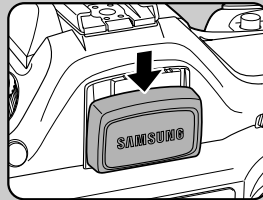

[Attaching the Viewfinder cap]

- Turn the power off to stop the remote control operation after it has been activated.
- The remote control may not operate in backlit conditions.
- The remote control does not work while the flash is being charged.
- When using the built-in flash, raise the flash into position first.
- The camera automatically returns to single frame shooting after the remote control shooting mode is left unused for 5 minutes.
- The remote control unit battery can send a remote control signal about 30,000 times.

Other Shooting Modes

Using Mirror Lock Up Function to Prevent Camera Shake

- Use the Mirror Lock Up function if camera shake is evident even when Cable Switch (optional) or Remote Control Unit (optional) is used.

When shutter release button is pressed, mirror pops up and shutter is released 2 seconds later if 2 second. Self-Timer is used. Avoid camera shake when mirror pops up by using this method. Follow the procedure below to take a picture with the mirror lock up.

1. Mount the camera to a tripod.
2. Use the **Fn** button and the four-way controller (▲) to select  (2 sec. Self-Timer). (p.53)
3. Focus on the subject.
4. Press the shutter release button fully.
The mirror pops up and the picture is taken 2 seconds later. AE lock is enabled with the exposure value set immediately before the mirror goes up.

Playing Back Still Pictures

Playing Back Images

- You can play back captured still pictures with the camera.

INFORMATION

- Use the included “Digimax Master” software to play back using a PC.
Refer to the software instructions for details. (p.169)

1. Press the  button after taking a picture.
The most recently captured image (image with the largest file number) is displayed on the LCD monitor.

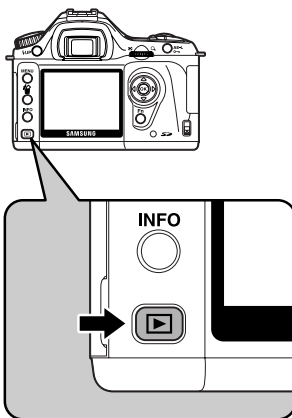

Playing Back Still Pictures

2. Press the four-way controller (◀▶).

- ◀ : The previous image appears.
- ▶ : The next image appears.

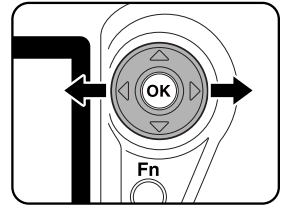

Rotating Images

- You can rotate images 90° counterclockwise at a time. Make images shot vertically easier to view.



1. Press the ▶ button after taking a picture.

The most recently captured image (image with the largest file number) is displayed on the LCD monitor.

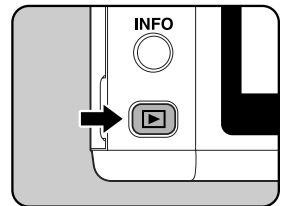

2. Press the four-way controller (▼).

The image is rotated 90° counterclockwise each time the button is pressed.

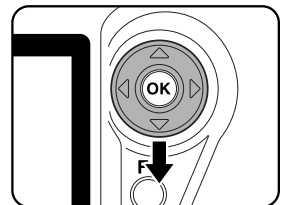

Playing Back Still Pictures

3. Press the **OK** button.

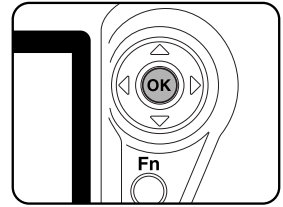

Image rotation information is saved.

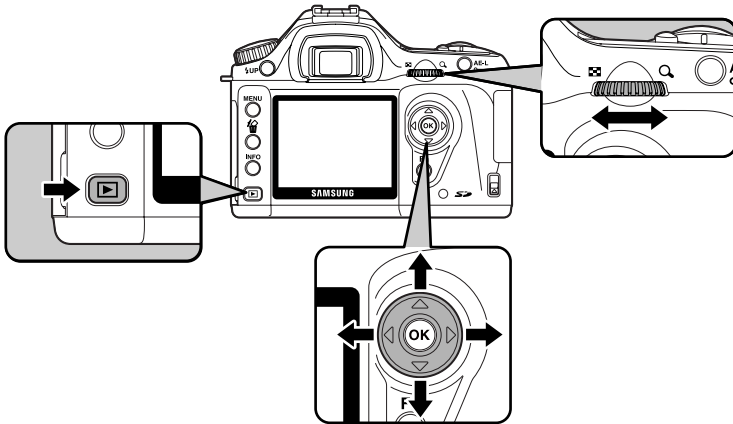

Enlarging Playback Images

- You can magnify images up to 12 times when displaying.



1. Press the  button and use the four-way controller ( ) to select an image.

The most recently captured image (image with the largest file number) is displayed first on the LCD monitor.



Playing Back Still Pictures

2. Turn the e-dial to the right (toward **Q**).

Image enlarges at each calibration and can be enlarged to 12 times the original. Turn to the left (toward **Q**) to return.

Press the **OK** button to return to the original size.

Press four-way controller (**▲▼◀▶**) in zoom display to change the display area.



INFORMATION

- The first calibration on the e-dial is 1.2 times. You can change this in [Mag to Strt Zm Plybk] in [C Custom Setting] menu. (p.99)

Nine-Image Display

- You can display nine images on the LCD monitor at the same time.

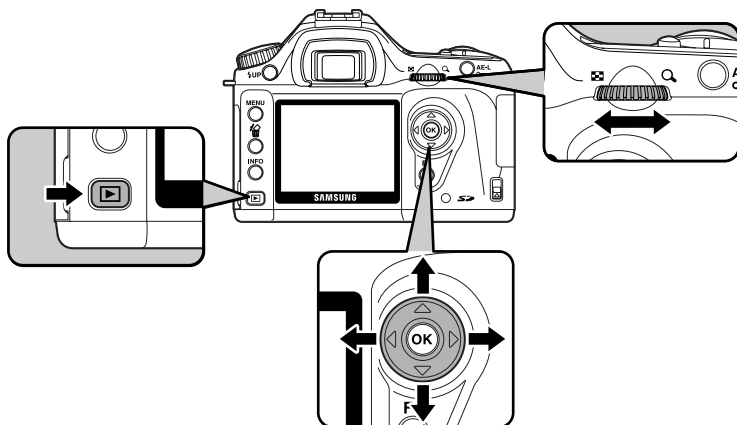

Playing Back Still Pictures





1. Press the  button.

The most recently captured image (image with the largest file number) is displayed on the LCD monitor.



2. Turn the e-dial to the left (toward ).

Up to nine thumbnail images will be displayed at once.

Press the four-way controller () to select an image.

A scroll bar appears at the right of the screen.

With an image selected in the bottom row, pressing the four-way controller () displays the next nine images.

[?] appears for an image that cannot be displayed.

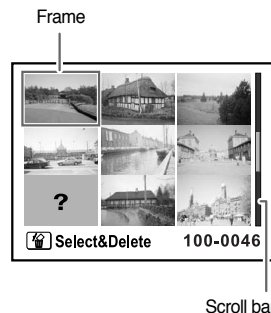

3. Turn the e-dial to the right (towards ) or press the **OK** button.

A full screen display of the selected image appears.





Playing Back Still Pictures

Slideshow

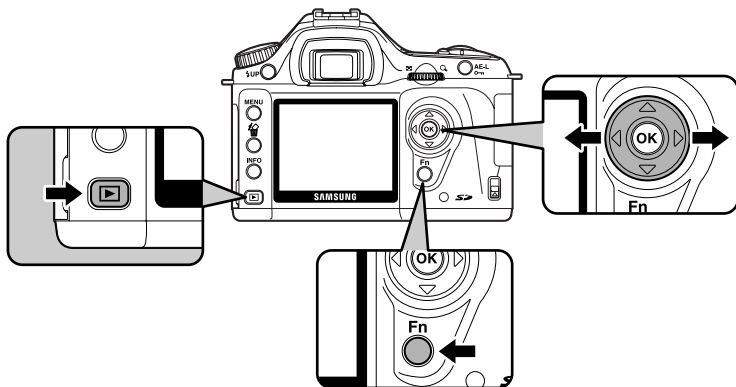
- You can play back all images recorded on your SD Memory Card successively. To start continuous playback, use the menu screen displayed on the LCD monitor.



1. Press the  button and use the four-way controller () to select an image to be displayed first.

The most recently captured image (image with the largest file number) is displayed first on the LCD monitor.



2. Press the **Fn** button.
The Fn menu appears.

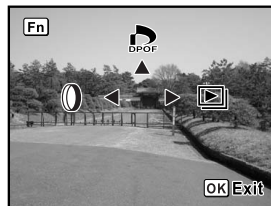

Playing Back Still Pictures

3. Press the four-way controller (▶).

Start screen is displayed and slideshow begins.

Press any button to end slideshow.

Press the shutter release button or the ▶ button, slide the main switch to ⌚ (preview) or turn the mode dial to change to Capture mode.

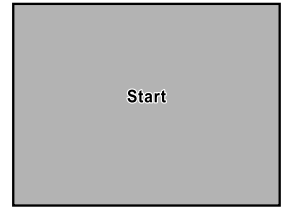

INFORMATION

- Set the display time for slideshow in the [▶ Playback] menu. Alternatively, start the slideshow from the [▶ Playback] menu. (p.156)

Connecting the Camera to AV Equipment

- By using the video cable, you can play back images using a TV or other device with a video IN jack as your monitor. Make sure that both the TV and the camera are turned off before connecting the cable.
 - Selecting the Video Output Format (p.163)

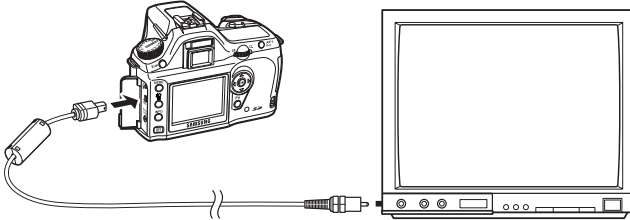

1. Open the terminal cover and connect the video cable to the USB/ Video terminal on your camera.
2. Connect the other end of the video cable to the video IN jack on the AV device.
3. Turn the AV device and camera on.

INFORMATION

- If you intend to use the camera continuously for a long period, use of the AC adapter (D-AC10, optional) is recommended. (p.26)
- For AV equipment with multiple video IN jacks (such as TVs), check the operating manual of the AV device, and select the video IN jack to which the camera is connected.
- Ensure that the video output format setting is the correct one for your country or region. (p.163)
- The camera LCD monitor turns off while the camera is connected to the AV device.

Processing Images with Filters

- You can edit shot images using digital filters. Processed images are saved under a different name.

INFORMATION

- RAW images cannot be processed using the digital filter.
- Additionally, set digital filters from the [▶ Playback] menu.

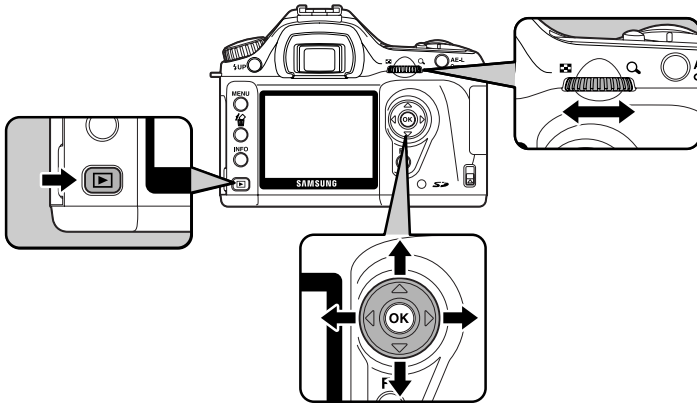

● Digital Filter

| | |
|-------|---|
| B&W | Convert to a black and white image. |
| Sepia | Add a vintage touch to photos by converting them to sepia colour. |
| Soft | Create a soft image by lightly fading the entire image. Select from three levels. |
| Slim | Change the horizontal and vertical ratio of images. Adjust height or width up to two times the original size. |

1. Press the **Fn** button in Playback mode.
The Fn menu appears.

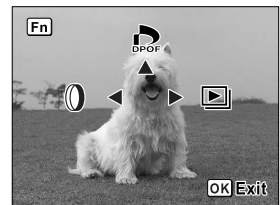

Processing Images with Filters

2. Press the four-way controller (◀).
The screen for selecting the filter appears.

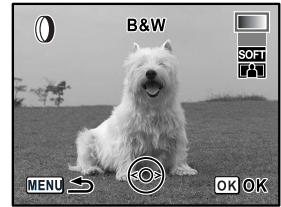

3. Use the four-way controller (◀▶) to select an image.
4. Use the four-way controller (▲▼) to select a filter.
Select a filter and preview the effects on the image. Proceed to Step 6 if [B&W] or [Sepia] is selected.

5. Adjust slimness with e-dial if slim filter is selected and softness if soft filter is selected.
Turn counterclockwise for wider and clockwise for slimmer if slim filter is selected. Select softness from three levels if soft filter is selected.
Use the four-way controller (◀▶) to select an image.
The image appears in the set slimness or softness.

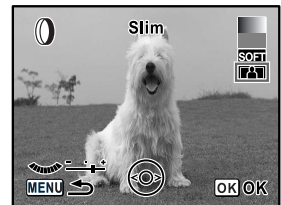

6. Press the OK button. The save confirmation screen appears.
7. Use the four-way controller (▲) to select [Save as].



8. Press the OK button.
The filtered image is saved under a different name.

Deleting Images

Deleting a Single Image

- You can delete one image at a time.

INFORMATION

- Deleted images cannot be restored.
- Protected images cannot be deleted.

1. Press the  button and use the four-way controller (◀▶) to select an image to delete.



2. Press the  button.
The Delete screen appears.

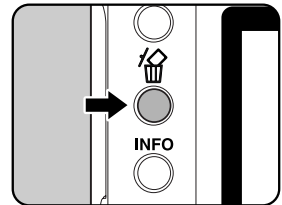

3. Use the four-way controller (▲) to select [Delete].

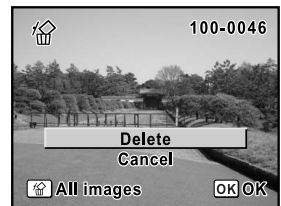

4. Press the **OK** button.
The image is deleted.

Deleting Images

Deleting All Images

- You can delete all saved images at once.

INFORMATION

- Deleted images cannot be restored.
- Protected images cannot be deleted.

1. Press the  button.

2. Press the  button twice.
The Delete All screen appears.

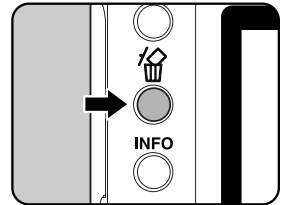

3. Use the four-way controller () to select [Delete All].



4. Press the **OK** button.
All images are deleted.

Deleting Images

Deleting Selected Images (from Nine-Image Display)

- You can delete multiple images from the nine-image display at once.

INFORMATION

- Deleted images cannot be restored.
- Protected images cannot be deleted.
- Only files in the same folder can be selected at once.

1. Press the  button.

The most recently captured image (image with the largest file number) is displayed first on the LCD monitor.



2. Turn the e-dial to the left (toward ).

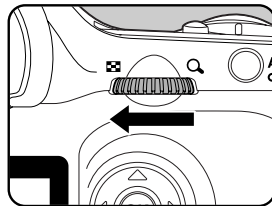

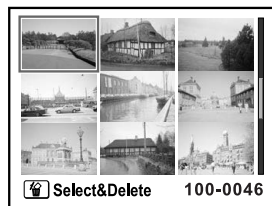

Nine thumbnail images appear.



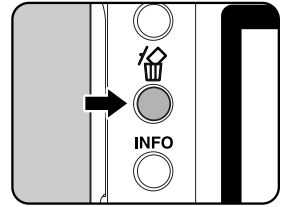

Deleting Images

3. Press the  button.
 appears above the images.

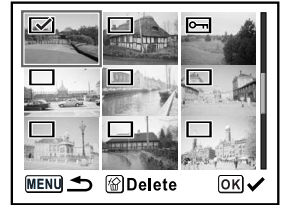

4. Use the four-way controller () to move to the images to delete and press the **OK** button.
Image is selected and appears.
Press **Fn** button to select all images (the selection of images may take time to complete depending on the number of images).



5. Press the  button.
The Delete confirmation screen appears.

6. Use the four-way controller () to select [Select&Delete].

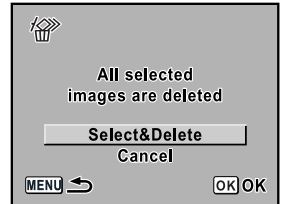



7. Press the **OK** button.
The selected images are deleted.

Protecting Images

Protecting Images from Deletion (Protect)

- You can protect images from being accidentally deleted.
- ※ Even protected images are deleted if the SD Memory Card is formatted.

1. Press the  button and use the four-way controller ( ) to select an image.

The most recently captured images (image with the largest file number) are displayed first on the LCD monitor.



2. Press the  button.

The Protect screen appears.

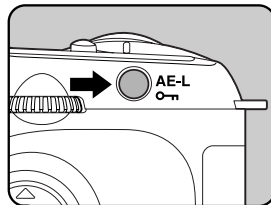

3. Use the four-way controller () to select [Protect].

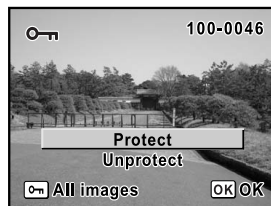

4. Press the **OK** button.



The selected image is protected.

INFORMATION

- Select [Unprotect] in Step 3 to cancel the Protect setting.
- The  symbol is displayed when playing back protected images. (p.17)

Protecting Images

Protecting All Images

1. Press the  button.
2. Press the  button twice.
The Protect all images screen appears.

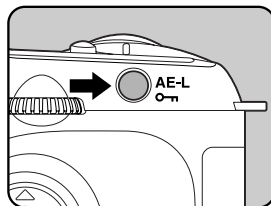

3. Press the four-way controller () to select [Protect] and press the **OK** button.
All images saved in the SD Memory Card are protected.



※ Select [Unprotect] in Step 3 to cancel the Protect setting on all of the images.

Setting the Printing Service (DPOF)



- You can order conventional photograph prints by taking the SD Memory Card with recorded images to a store for a printing service.
DPOF (Digital Print Order Format) settings allow you to specify the number of copies or to imprint the date.

※ DPOF settings cannot be applied to RAW images.

Printing Single Images

- Set the following items for each image.

| | |
|--------|---|
| Copies | Selects the number of copies. You can print up to 99 copies. |
| Date | Specifies whether you want the date inserted on the print or not. |

1. Press the  button and use the four-way controller ( ) to select an image.

2. Press the **Fn** button.
The Fn menu appears.

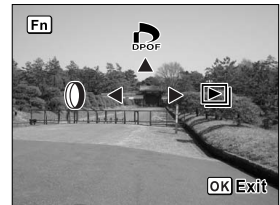

3. Press the four-way controller ().
The DPOF screen appears.
If DPOF settings have already been made for an image, the previous number of prints and date setting ((on) or (off)) will be displayed.

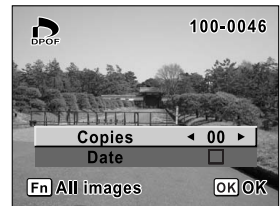

Setting the Printing Service (DPOF)

- Use the four-way controller (◀▶) to choose the number of copies and press the four-way controller (▼).
The frame moves to [Date].

- Use the four-way controller (◀▶) to choose whether to insert the date () or not ().
 - () : The date will be imprinted.
 - () : The date will not be imprinted.

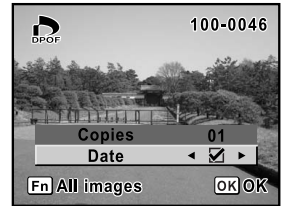

- Press the **OK** button.
The DPOF settings are saved and the camera returns to playback status.

INFORMATION

- Depending on the printer or printing equipment at the photo processing lab, the date may not be imprinted on the pictures even if the DPOF setting was made.
- To cancel DPOF settings, set the number of copies to [00] in Step 4 and press the **OK** button.

Setting the Printing Service (DPOF)

Settings for All Images

1. Press the **Fn** button in Playback mode.
The Fn menu appears.

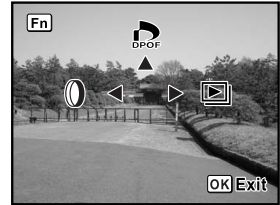

2. Press the four-way controller (▲).
The DPOF screen appears.

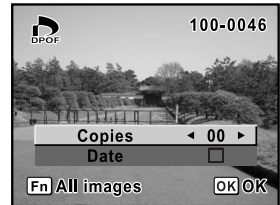

3. Press the **Fn** button.
The screen for making DPOF settings for all images appears.

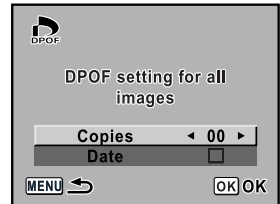

4. Use the four-way controller (◀▶) to choose the number of copies and whether to insert the date () or not ().
Refer to Steps 4 and 5 in "Printing Single Images" (p.78) for details of how to make the settings.

Setting the Printing Service (DPOF)

5. Press the **OK** button.

The DPOF settings for all the images are saved and the camera returns to playback status.

INFORMATION

- The number of copies specified in settings for all images applies to all the images. Before printing, check that the number is correct.
- Settings for single images are cancelled when settings are made for all images.

Printing Using PictBridge

- This function lets you print images directly from the camera without using a PC (direct printing). Connect the camera and PictBridge compatible printer with the included USB cable to print directly. Select the images you want to print, the number of copies and whether to insert the date or not on the camera after connecting to the printer. Direct printing is performed in the following steps.

Set [Transfer Mode] on camera to [PictBridge]



Connect the camera to the printer (p.83)



Set the printing options (p.77)

Print single images (p.84)

Print all images (p.86)

Print with DPOF settings (p.88)



Disconnect the camera from the printer (p.88)

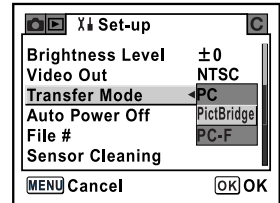

INFORMATION

- Use of the AC adapter (D-AC10, optional) is recommended when connecting the camera to a printer. The printer may not work properly or the image data may be lost if the batteries run out of power while the camera is connected to the printer.
- Do not disconnect the USB cable during data transfer.
- Depending on the type of printer, not all the settings made on the camera (such as print settings and DPOF settings) may be valid.
- A printing error may occur if the selected number of copies exceeds 500.
- You cannot use the camera to select multiple images for printing on a single sheet. Make the settings on the printer. For details, refer to the operating manual for your printer.
- RAW images cannot be printed directly. Use a PC to print RAW images.
- See the software instructions when connecting to a PC. (p.169)

Printing Using PictBridge

Setting [Transfer Mode]

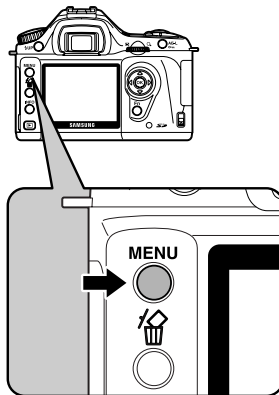

1. Press the **MENU** button.

The [ Rec. Mode] menu appears.

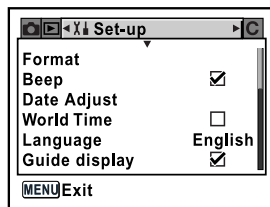

2. Use the four-way controller ( ) to select the [ Set-up] menu.



3. Use the four-way controller ( ) to select [Transfer Mode].

4. Press the four-way controller ().

A pop-up menu appears.

Printing Using PictBridge

5. Use the four-way controller (▲▼) to select [PictBridge].

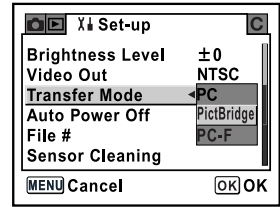

6. Press the **OK** button.
The setting is changed.

7. Press the **MENU** button.

Connecting the Camera to the Printer

1. Turn the camera off.
2. Connect the camera and PictBridge compatible printer using the USB cable supplied with the camera.

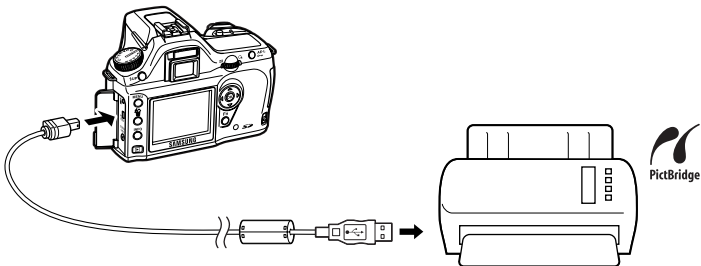

Printing Using PictBridge

3. Turn the printer on.
4. After printer start-up is complete, turn the camera on.
The PictBridge menu appears.

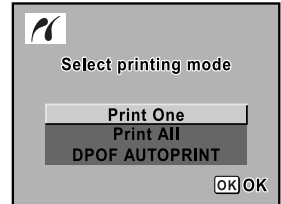

INFORMATION

- PictBridge menu is not displayed if [Transfer Mode] is set to [PC] or [PC-F].

Printing Single Images

1. Use the four-way controller (▲▼) to select [Print One] on the PictBridge menu.

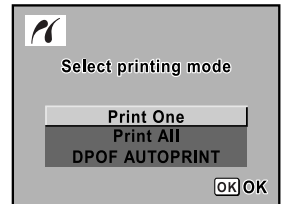

2. Press the **OK** button.
The Print one screen appears.

Printing Using PictBridge

3. Use the four-way controller (◀▶) to choose an image to print.

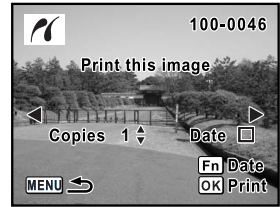

4. Use the four-way controller (▲▼) to choose the number of copies. You can print up to 99 copies.

5. Use the **Fn** button to choose whether to insert the date () or not ().

() : The date will be printed.

() : The date will not be printed.

6. Press the **OK** button.

The print settings confirmation screen appears.

Proceed to Step 12 to print the images by default.

To change the print settings, go to Step 7.

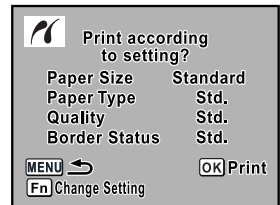

7. Press the **Fn** button.

The screen for changing print settings appears.

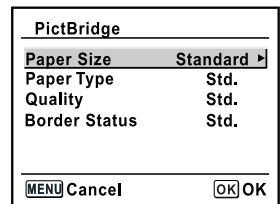

8. Select [Paper Size] and press the four-way controller (▶).

The Paper Size screen appears.

Printing Using PictBridge

9. Use the four-way controller (▲▼◀▶) to choose the paper size.

You can only choose a size that is supported by your printer.
When the Paper Size is set to [Standard], images are printed according to the printer settings.

| Paper Size | |
|------------|-----------|
| Standard | 2L |
| Card | 8"x10" |
| L | A4 |
| 100x150 | Letter |
| Postcard | 11"x17" |
| 4"x6" | A3 |

MENU Cancel OK OK

10. Press the **OK** button.

11. [Repeat Steps 8 to 10 to set [Paper Type], [Quality] and [Border Status].

The print settings change screen appears after each item has been set.

When the Paper Size is set to [Standard], images are printed according to the printer settings.

- [Paper Type] : ■■■ (Best), ■■■ (Better), ■■■ (Good)

- [Quality] : ■■■ (Super fine), ■■■ (Fine), ■■■ (Normal)

12. Press the **OK** button twice.

The image is printed according to the settings.

Press the **MENU** button to cancel printing.

Printing All Images

1. Use the four-way controller (▲▼) to select [Print All] on the PictBridge menu.

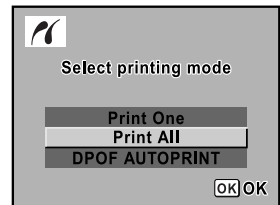

2. Press the **OK** button.

The Print all images screen appears.

Printing Using PictBridge

3. Choose the number of copies and whether to imprint the date or not.

The number of copies and the date setting that you choose apply to all of the images.

Refer to Steps 4 and 5 of "Printing Single Images" (p.85) for details on how to change the settings.

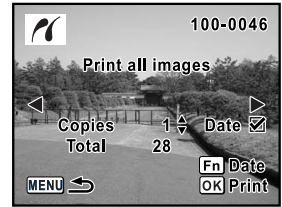

4. Press the **OK** button.

The print settings confirmation screen appears.

Refer to Steps 7 and 11 of "Printing Single Images" (p.85 and 86) for details on how to change the settings.

5. Press the **OK** button on the print settings confirmation screen.

All the images are printed according to the settings.

Press the **MENU** button to cancel printing.

Printing Using PictBridge

Printing Images Using the DPOF Settings

1. Use the four-way controller (▲▼) to select [DPOF AUTOPRINT] on the PictBridge menu.

2. Press the **OK** button.

The Print w/ DPOF settings screen appears.

Use the four-way controller (◀▶) to check the number of copies for each image, whether the date is imprinted or not, and total number of copies. Print settings are set with the Print Service.

(p.77)

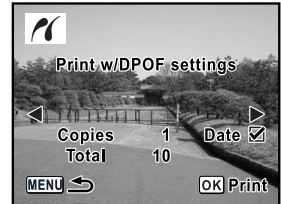

3. Press the **OK** button.

The print settings confirmation screen appears.

Refer to Steps 7 and 11 of "Printing Single Images" (p.85 and 86) for details on how to change the settings.

4. Press the **OK** button on the print settings confirmation screen.

The images are printed according to the settings.

Press the **MENU** button to cancel printing.

Disconnecting the Cable from the Printer

■ Disconnect the cable from the printer when you have finished printing.

1. Turn off the camera.

2. Disconnect the USB cable from the camera and printer.

4 Menu Reference

Explains the functions of GX-1S by buttons and menus.

| | |
|----------------------------------|-----|
| Using the Button Functions | 90 |
| Using the Menu | 94 |
| Using the Fn Menu | 100 |
| Using the Mode Dial | 102 |

When using menus and Fn menu, items which cannot be changed due to camera settings appear grey and cannot be selected.

Using the Button Functions





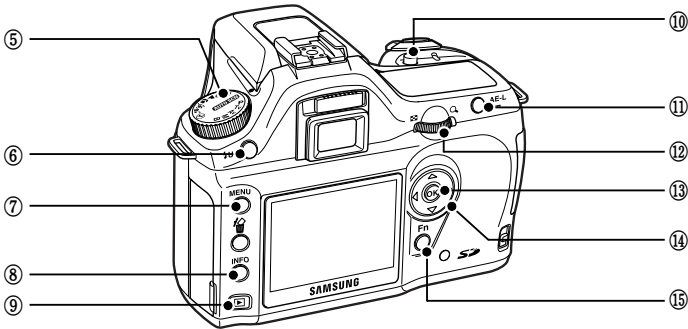
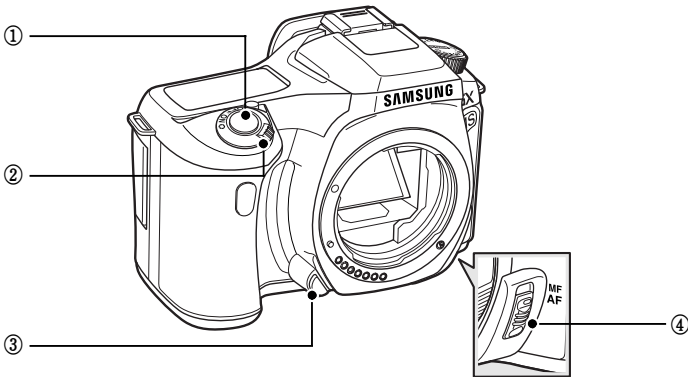

Capture Mode

- Functions of buttons used during shooting.



- ① Shutter release button
Press to capture images. (p.43)
- ② Main switch
Move to turn the power on/off (p.30) and confirm the depth of field (Preview) (p.128).
- ③ Lens unlock button
Press to detach lens. (p.36)

Using the Button Functions

- ④ **Focus mode lever**
Switches between Autofocus mode (p.116) and Manual focus mode (p.124).
- ⑤ **Mode dial**
Changes the Shooting mode. (p.102)
- ⑥ **⚡UP button**
Press to pop up the built-in flash. (p.47)
- ⑦ **MENU button**
Displays the [ Rec. Mode] menu (p.96). Press the four-way controller (▶) to display [ Playback] menu (p.96), [ ↓ Set-up] menu (p.97) and [ Custom Setting] menu. (p.98)
- ⑧ **INFO button**
Press to show shooting information on the LCD monitor. (p.15)
- ⑨ ** button**
Switches to the Playback mode. (p.61)
- ⑩ ** Av button**
Press to set aperture and EV compensation values. (p.135, p.140)
- ⑪ **AE-L button**
Locks the exposure before shooting. (p.141)
Automatically adjusts the appropriate exposure in the Manual mode. (p.137)
- ⑫ **e-dial**
Sets shutter speed, aperture, and EV compensation values. (p.133, 135, 140)
- ⑬ **OK button**
Saves the setting you selected in the menu.
- ⑭ **Four-way controller (▲▼◀▶)**
Uses it to move cursor or change items in menus and Fn menu.
- ⑮ **Fn button**
Press to display the Fn menu. Press the four-way controller (▲▼◀▶) to choose the next operation. (p.100)

Using the Button Functions

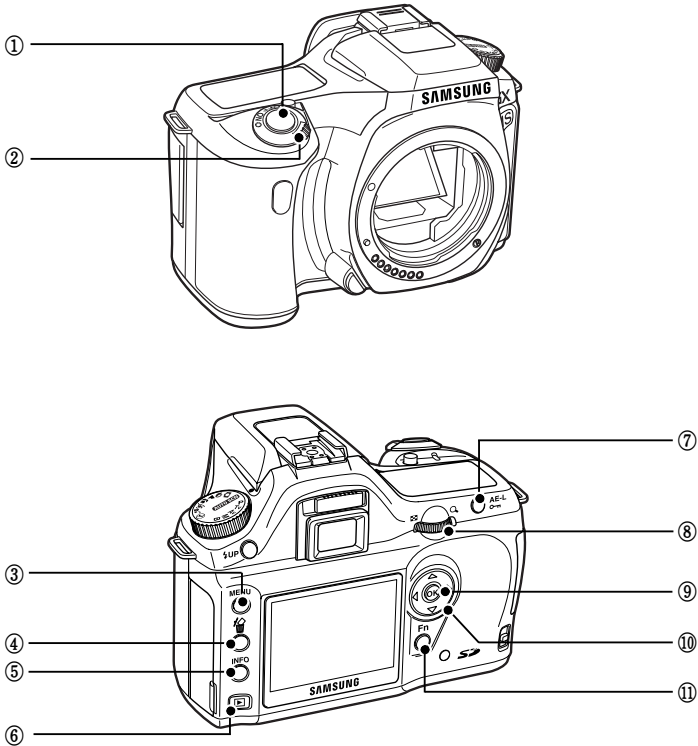

Playback Mode

- Functions of buttons used during playback.







- ① Shutter release button
Press to switch to capture mode.
- ② Main switch
Move to turn the camera on and off. (p.30)
- ③ **MENU** button
Press to display the [▶ Playback] menu (p.96). Next, press the four-way controller (◀▶) to display [X Set-up] menu (p.97), [C Custom Setting] menu (p.98) and [📷 Rec. Mode] menu (p.96).

Using the Button Functions

- ④  button
Press to delete images. (p.71)
- ⑤ **INFO** button
Press to show shooting information on the LCD monitor. (p.16)
- ⑥  button
Press to switch to capture mode.
- ⑦  button
Press to protect images from being accidentally erased. (p.75)
- ⑧ e-dial
Uses it to enlarge an image (p.63) or display nine images at the same time. (p.64)
- ⑨ **OK** button
Saves the setting you selected in the menu or playback screen.
- ⑩ Four-way controller (▲▼◀▶)
Uses it to move cursor or change items in menus, Fn menu and playback screen.
- ⑪ **Fn** button
Press to display the Fn menu. Press the four-way controller (▲◀▶) to choose your next operation.
(p.101)

Using the Menu

How to Operate the Menu

- This section explains operation methods for [ Rec. Mode] menu, [ Playback] menu, [ Set-up] menu and [ Custom Setting] menu.



● Displaying the Menu screen

1. Press the **MENU** button in Capture mode.

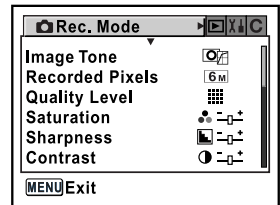
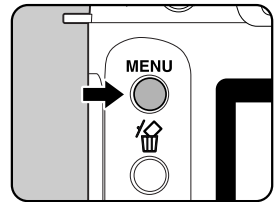
- The [ Rec. Mode] menu appears on the LCD monitor.



2. Press the four-way controller ().

- [ Playback] menu, [ Set-up] menu and [ Custom Setting] menu appear in order each time the four-way controller is pressed.

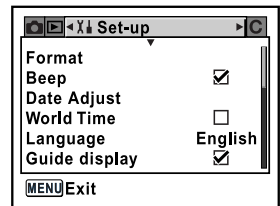

Using the Menu

- Select a menu item and set
- Procedure to set the [Quality Level] on the [ Rec. Mode] menu is explained as an example.

3. Use the four-way controller (▲▼) to choose an item.

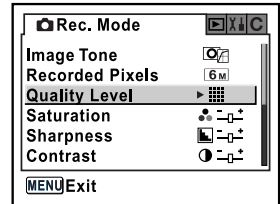

4. Press the four-way controller (▶).

- Available [Quality Level] options appear.

Press the four-way controller (▶) to move to the pop-up menu if there is one.

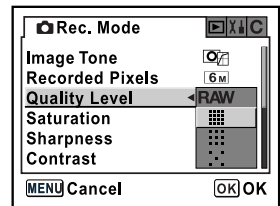







5. Use the four-way controller (▲▼) to select a setting.

6. Press the **OK** button.

- The camera returns to the menu screen. Next, set other items.
- Press the **MENU** button to return to Capture or Playback mode.

INFORMATION

- Even after you press the **MENU** button and close the menu screen, your settings will not be saved if the camera is turned off improperly (such as by removing the batteries while the camera is on).
- You can use the e-dial to switch between the [ Rec. Mode] menu, the [ Playback] menu, [ Set-up] menu, and [ Custom Setting] menu when no pop-up menu is displayed.
- If the **MENU** button is pressed in Capture mode, the [ Rec. Mode] menu appears.
If the **MENU** button is pressed in Playback mode, the [ Playback] menu appears.

Using the Menu

■ [Rec. Mode] Menu Settings

Perform settings related to capturing in the [ Rec. Mode] menu.

| Item | Function | Page |
|------------------|--|-------|
| Image Tone | Sets the colour tone of pictures. | p.106 |
| Recorded Pixels | Sets the recording size of images. | p.107 |
| Quality Level | Sets the image quality. | p.108 |
| Saturation | Sets the colour saturation. | p.109 |
| Sharpness | Makes the image outlines sharp or soft. | p.109 |
| Contrast | Sets the image contrast. | p.109 |
| Instant Review | Sets the Instant Review time. | p.165 |
| Auto Bracket | Sets Auto Bracket shooting. | p.144 |
| AE Metering | Selects the part of the screen to use for measuring brightness and determining exposure. | p.129 |
| Swthc dst msr pt | Selects the part of the screen to set focus to. | p.120 |
| AF Mode | Selects the autofocus mode. | p.119 |
| Flash Exp. Comp. | Adjusts the flash exposure to brighten or darken the image. | p.145 |

■ [Playback] Menu Settings

Perform settings related to playback and editing images in the [ Playback] menu.

| Item | Function | Page |
|------------------|--|-------|
| Plybk dsply mthd | Sets capturing information to show during playback. | p.155 |
| Bright Portion | Sets to display over exposed area warning during Instant Review or Playback. | p.155 |
| Digital Filter | Edits captured images to black and white or sepia tint, or add softening and slimming effects. | p.69 |
| Slideshow | Plays back recorded images one after another. | p.66 |

Using the Menu

■ [Set-up] Menu Settings

Perform various settings related to the camera in the [ Set-up] menu.

| Item | Function | Page |
|------------------|---|-------|
| Format | Formats the SD Memory Card. | p.157 |
| Beep | Switches the beep tone on/off. | p.158 |
| Date Adjust | Sets the date format and time. | p.158 |
| World Time | Allows the display of local time when travelling abroad. | p.159 |
| Language | Changes the language in which menus and messages appear. | p.162 |
| Guide display | Sets to display indicators in LCD monitor. | p.162 |
| Brightness Level | Changes the brightness of the LCD monitor. | p.163 |
| Video Out | Sets the output format to the TV monitor. | p.163 |
| Transfer Mode* | Sets the USB cable connection (PC or printer). | p.82 |
| Auto Power Off | Sets the time to turn off automatically. | p.164 |
| File # | Sets the method used to add file numbers. | p.164 |
| Sensor Cleaning | Locks the mirror in the up position for cleaning the CCD. | p.190 |
| Reset | Resets all settings other than Date Adjust, Language, Video Out and World Time. | p.166 |

※ Refer to the software instructions for details on connecting the camera to a PC. (p.169)

Using the Menu

■ [C Custom Setting] Menu Settings

Set custom functions to fully use the functions of a SLR camera with the Custom Function Menu. The default setting does not use Custom Function.

[C Custom Setting] menu settings are activated when [Setting], the first item, is (on).

| Item | Function | Page |
|----------------------|---|------------|
| Setting | Sets the Custom function to use the Custom Function Menu. | - |
| Noise Reduction | Sets Noise Reduction in slow speed shooting. | - |
| Expsr Setting Steps | Sets the adjustment steps for exposure. | p.141 |
| ISO Corction in AUTO | Automatically corrects sensitivity range when Sensitivity is set to [AUTO]. | p.113 |
| ISO Snstvy Wrn Dspl | Sets the maximum sensitivity level. ISO Sensitivity Warning Display appears when set sensitivity is reached or exceeded. | p.114 |
| Link AF Point and AE | Use to link exposure and focus point during multi-segment metering. | p.130 |
| Meter Operating Time | Sets the exposure metering time. | p.131 |
| AE-L with AF locked | Sets the exposure value when focus is locked. | - |
| Recordable Image No. | Use to switch number of recordable images in the LCD panel and viewfinder to number of continuous shooting recordable images when shutter release button is pressed halfway. | - |
| OK btn when shooting | Sets the action for the OK button when pressed during shooting. | p.118, 121 |
| AE-L btn on M expsr | Selects the exposure adjustment method when the AE-L button is pressed in M (Manual) mode. | p.139 |
| Superimpose AF Area | Use to display superimposed AF area in the viewfinder. | p.120 |
| AF in remote control | sets Autofocus when shooting with remote control. Shutter releases after AF activates if shutter is released from remote control when [On]. Shutter cannot be released until in focus. AF does not activate at shutter release from remote control when [Off]. | - |

Using the Menu

| Item | Function | Page |
|-----------------------------------|--|-------|
| FI with S lens used ^{*1} | Sets to enable focus indicator when screw mount lens is in use. Lens is recognized even when lens is not attached to the camera when enabled. | - |
| Using aperture ring ^{*2} | Sets to enable shutter release when lens aperture ring is set at other than A. | - |
| Release when Chrging | Use to release shutter while the built-in flash is charging. | p.146 |
| Instant Review Dsply | Use to display histogram during Instant Review. | p.165 |
| Mag to Strt Zm Plybk | Sets the initial magnification of the zoom playback. Choose from [1.2 times], [2 times], [4 times], [8 times] and [12 times]. The default setting is [1.2 times]. | - |
| Man. WB Measurement | Use to meter entire screen or Spot area when setting white balance to manual. | p.111 |
| Colour Space | Sets the colour space to use. | p.115 |
| Reset Custom Fncion | Resets all the settings in the Custom Function menu to the defaults. | p.167 |

*1 : When the screw mount lens is in use, [FI with S lens used] menu is available.

*2 : When a lens that has aperture ring is in use, [Using aperture ring] menu is available.

Using the Fn Menu

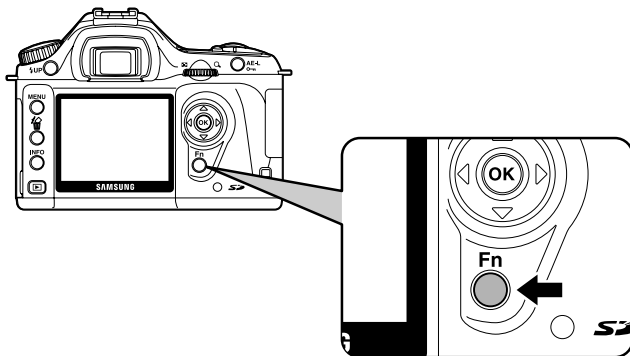

Capture Mode

- Press the **Fn** button while taking a picture.
The Fn menu appears.

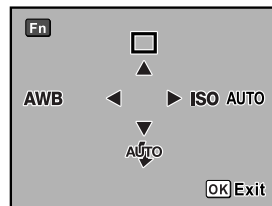

- Press the four-way controller (▲▼◀▶) to set the operation.

| Four-way controller | Item | Function | Page |
|---------------------|---------------|---|-------------------------|
| ▲ | Drive Mode | Selects Continuous shooting, Self-Timer, Remote control or Auto bracket. | p.51, p.53, p.57, p.142 |
| ▼ | Flash Mode | Adjusts the method of flash discharge. | p.47 |
| ◀ | White Balance | Adjusts the colour for the colour of the light source illuminating the subject. | p.110 |
| ▶ | Sensitivity | Sets the sensitivity. | p.113 |

Using the Fn Menu

Playback Mode

- Press the **Fn** button during playback.
The Fn menu appears.

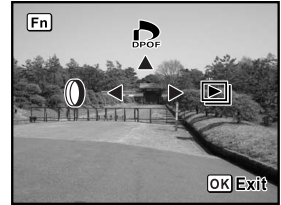

- Press the four-way controller (▲◀▶) to set the operation.

| Four-way controller | Item | Function | Page |
|---------------------|----------------|---|------|
| ▲ | DPOF Settings | Sets the DPOF settings. | p.77 |
| ◀ | Digital Filter | Edits captured images to black and white or sepia tint, or adds softening and slimming effects. | p.69 |
| ▶ | Slideshow | Plays back recorded images one after another. | p.66 |

Using the Mode Dial

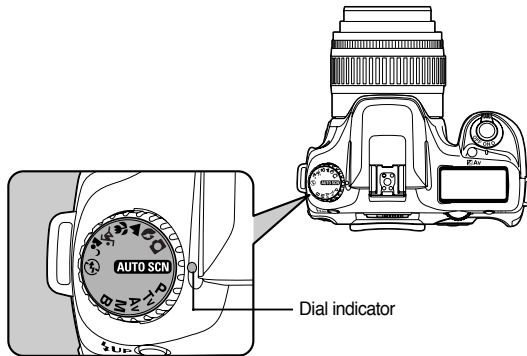

- You can change the Shooting mode by setting the icons on the mode dial to the dial.

| Item | Function | Page |
|------------------------|--|------|
| (Auto Scene) | Selects automatically from Normal, Portrait, Landscape, Macro, and Moving Object Modes. | P.45 |
| (Normal) | The basic picture-taking mode. | |
| (Portrait) | Optimal for capturing portraits. | |
| (Landscape) | Deepens the focus range, emphasizes colour and saturation of trees and the sky, and produces a bright image. | |
| (Macro) | Lets you take vibrant pictures of flowers and other small subjects at short distances. | |
| (Moving Object) | Lets you take sharp pictures of a quickly moving subject, such as a sporting event. | |
| (Night Scene Portrait) | Lets you capture people against a night view or dusk. | |
| (Flash OFF) | The built-in flash is deactivated. Other settings are the same as (Normal). | |

INFORMATION

- For (Night Scene Portrait), the shutter speed becomes slower in dark places, even if the built-in flash is used. Use a tripod to avoid camera shake.

Using the Mode Dial

| Item | Function | Page |
|----------------------------------|--|-------|
| P (Program) | Automatically sets shutter speed and aperture to the most suitable exposure when taking pictures. | p.132 |
| Tv (Shutter Priority) | Lets you set the desired shutter speed for expressing the motion of moving subjects. Take pictures of fast moving subjects that look still or subjects that give a sense of movement. | p.133 |
| Av (Aperture Priority) | Lets you set the desired aperture for controlling the depth of field. Use to blur or focus on the background. | p.135 |
| M (Manual) | Lets you create the picture you have in mind by combining set shutter speed and aperture. | p.137 |
| B (Bulb) | Lets you capture images that require slow shutter speeds such as fireworks and night scenes. | p.139 |

MEMO

A large, empty rectangular box with rounded corners, intended for writing a memo. The box is outlined in a thin gray border and occupies most of the page below the header.

5 Function Reference



Introduces functions to further enhance your GX-1S experience.

| | |
|---|-----|
| Setting the Recorded Pixels and Quality Level | 106 |
| Focusing | 116 |
| Setting the Exposure | 126 |
| Using the Built-in Flash | 145 |
| Using an External Flash (Optional) | 150 |
| Settings During Playback | 155 |
| Camera Settings | 157 |
| Resetting to Default Settings | 166 |

Setting the Recorded Pixels and Quality Level

Setting the Image Tone

- Set the basic colour tone of pictures. The default setting is  (Bright).

| | | |
|---|---------|---|
|  | Bright | Images are finished brightly, with high contrast and sharp focus. |
|  | Natural | Images are finished naturally and suitable for retouching. |

- Set in [Image Tone] in the [ Rec. Mode] menu. (p.96)

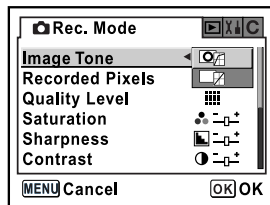

INFORMATION

- Settings cannot be changed in Scene mode. Setting is fixed to  (bright).

Setting the Recorded Pixels and Quality Level

Setting the Recorded Pixels

- You can select the number of recorded pixels from **6M** (3008x2008/ 3008x2000), **4M** (2400x1600) and **1.5M** (1536x1024). The more pixels there are, the larger the picture and the bigger the file size. The file size will also differ according to quality level settings. The default setting is **6M** (3008x2000).

| | | |
|-------------|-------------------------------------|----------------------------------|
| 6M | 3008x2008 (RAW) 3008x2000 (JPEG) | Suited for printing on A3 paper. |
| 4M | 2400x1600 | Suited for printing on A4 paper. |
| 1.5M | 1536x1024 | Suited for printing on A5 paper. |

- Set in [Recorded Pixels] in the [ Rec. Mode] menu. (p.96)

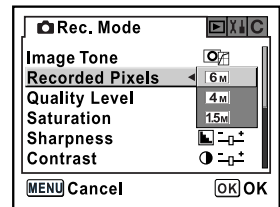





INFORMATION

- [Recorded Pixels] cannot be selected if the [Quality Level] is set to RAW. (Fixed at 3008x2008)

Setting the Recorded Pixels and Quality Level

Setting the Quality Level

- You can set the image quality level. The file size will also differ according to the Recorded Pixels settings. The default setting is  (Best).

| | | |
|---|--------|--|
| RAW | RAW | RAW data is CCD output data saved without processing. Effects such as White Balance, Contrast, Saturation and are not applied to the image but such information is saved. When image data is transferred to a PC, the supplied Digimax Master software can save images in JPEG or TIFF file formats. |
|  | Best | Lowest compression rate, suited for printing large pictures such as A4 size. Image is saved in JPEG format. |
|  | Better | Standard compression rate, suited for viewing as photographs or on your computer screen. Image is saved in JPEG format. |
|  | Good | Highest compression rate, suitable for attaching to e-mail or posting on websites. Image is saved in JPEG format. |

- Set in [Quality Level] in the [ Rec. Mode] menu. (p.96)

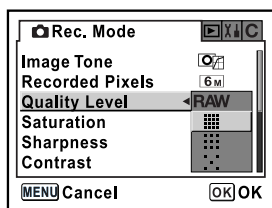

Setting the Recorded Pixels and Quality Level

Setting the Saturation/ Sharpness/ Contrast

- Select from five levels of Saturation, Sharpness and Contrast. The default setting is [0 (Standard)] for all.

| | |
|------------|---|
| Saturation | Sets the colour saturation. |
| Sharpness | Makes the image outlines sharp or soft. |
| Contrast | Sets the image contrast. |

- Set [Saturation], [Sharpness] and [Contrast] in the [ Rec. Mode] menu. (p.96)

INFORMATION

- Settings cannot be changed in Scene mode (p.45).

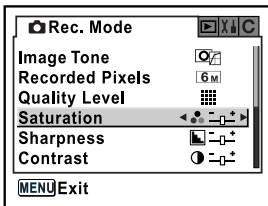

Towards + : Higher saturation

Towards - : Lower saturation

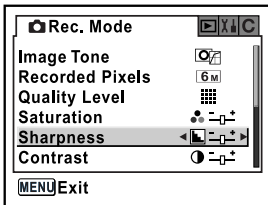

Towards + : Higher sharpness

Towards - : Lower sharpness

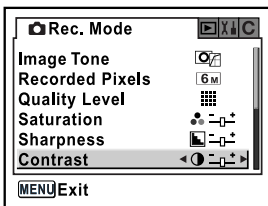







Towards + : Higher contrast

Towards - : Lower contrast

Setting the Recorded Pixels and Quality Level

Setting the White Balance

- The colour of the subject changes with the light source. For example, the same white object will be a different shade of white in daylight than under a light bulb. In cameras using film, this is adjusted by changing the film or using filters. In digital cameras, the whiteness is adjusted using white balance. The default setting is **AWB** (Auto).

| | | |
|---|-------------------|--|
| AWB | Auto | Automatically adjusts the white balance. (About 4000 to 8000K) |
|  | Daylight | For use when taking pictures in sunlight. (About 5200K) |
|  | Shade | For use when taking pictures in the shade. (About 8000K) |
|  | Cloudy | For use when taking pictures on cloudy days. (About 6000K) |
|  | Fluorescent Light | For use this when taking pictures under fluorescent lighting. Select the type of fluorescent light, from W (white) (About 4200K), N (neutral white) (About 5000K), and D (daylight) (About 6500K). |
|  | Tungsten Light | For use when taking pictures under light bulb or other tungsten light. (About 2850K) |
|  | Flash | For use to take pictures using the built-in flash. (About 5400K) |
|  | Manual | For use when taking pictures by manually adjusting the white balance. |

※ The colour temperature (K) is an estimate. This does not indicate precise colours.

- Set [White Balance] in the Fn menu. (p.100)

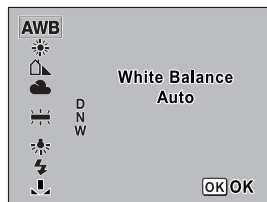

INFORMATION

- Refer to p.111 for manual adjustment method.
- White balance cannot be adjusted in Scene mode (p.45).

Setting the Recorded Pixels and Quality Level

Colour Temperature

The colour of light shifts towards blue as the colour temperature rises, and towards red as the colour temperature falls. Colour temperature describes this change in light colour in terms of absolute temperature (K: Kelvin).

This camera is capable of setting the white balance to enable taking pictures with natural colouring under a variety of lighting conditions.

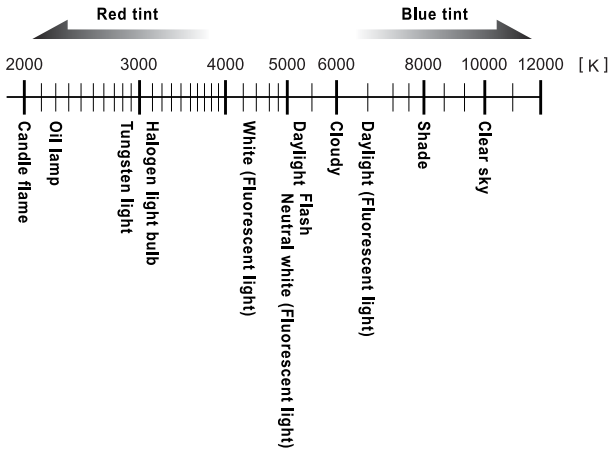

Adjusting the White Balance Manually

- You can adjust the white balance depending on the light source when taking pictures. With Manual White Balance, the camera can store delicate shades that cannot be precisely adjusted with the white balance preset values provided in the camera. This provides the optimum white balance for your surroundings.

1. Set the mode dial to **P**, **Tv**, **Av**, **M**
2. Press the **Fn** button.
 - The Fn menu appears.
3. Press the four-way controller (◀).
 - The White Balance screen appears.

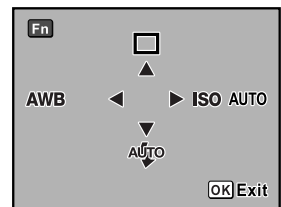

Setting the Recorded Pixels and Quality Level

4. Use the four-way controller (▼) to select  (Manual).

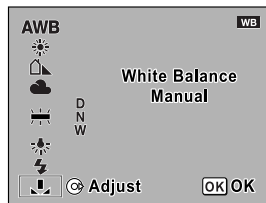

5. Press the four-way controller (▶).
- The message screen appears.

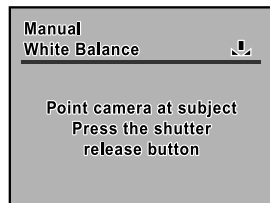

6. Fully display a white or grey sheet of paper in the viewfinder under the light to adjust white balance.

7. Press the shutter release button fully.

- Slide the focus mode lever to **MF** when the shutter cannot be released.

[OK] appears on the LCD monitor when setting is completed.

[NG] appears when setting is not completed successfully.

8. Press the **OK** button.

INFORMATION

- No image is recorded when the shutter release button is pressed to adjust the white balance.
- Press the **Fn** button when adjustment is unsuccessful to set again.

- You can set the range to measure white balance when setting manually.

White balance is measured using the entire screen using multi-segment metering (p.129) if [Entire screen] is selected for [Man. WB Measurement] in [**C** Custom Setting] menu (p.99). White Balance is only adjusted in the spot metering area (p.130) if [Spot metering area] is selected.

- If picture is extremely overexposed or underexposed, white balance may not be adjusted. In this case, set an appropriate exposure and re-adjust the white balance.

Setting the Recorded Pixels and Quality Level

Setting the Sensitivity

- You can set the sensitivity to suit the brightness of the surroundings. The sensitivity can be set to [AUTO] or within a sensitivity range equivalent to ISO 200 to 3200. The default setting is [AUTO]. Set [Sensitivity] in the Fn menu. (p.100)

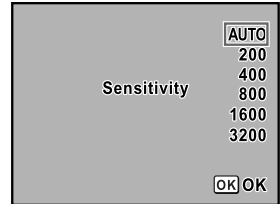

INFORMATION

- Captured images can show more noise if higher Sensitivity is set.

Setting the Range of Automatic Correction in AUTO

- Set range to automatically correct sensitivity when Sensitivity is set to [AUTO]. The sensitivity is automatically corrected in the range of [ISO 200- 800] by default.

| | | |
|---|--------------|---|
| 1 | ISO 200-800 | Corrects sensitivity automatically in the range of ISO 200 to 800. |
| 2 | ISO 200-400 | Corrects sensitivity automatically in the range of ISO 200 to 400. |
| 3 | ISO 200-1600 | Corrects sensitivity automatically in the range of ISO 200 to 1600. |
| 4 | ISO 200-3200 | Corrects sensitivity automatically in the range of ISO 200 to 3200. |

- Set in [ISO Corction in AUTO] in the [C Custom Setting] menu. (p.98)

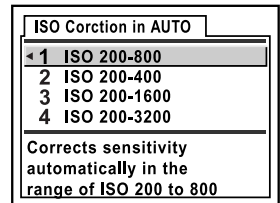

Setting the Recorded Pixels and Quality Level

INFORMATION

Sensitivity is not corrected in the following situations or settings.

- Exposure mode is **M** (Manual) or **B** (Bulb) mode
- Flash is discharged
- Auto bracketing
- EV Compensation

ISO Sensitivity Warning Display

- ISO Sensitivity Warning appears in the viewfinder when a sensitivity value of your choice is reached or exceeded. Set a sensitivity that is not regularly used to avoid forgetting to reset when sensitivity is raised. ISO Sensitivity Warning is not displayed by default.

| | | |
|---|----------|--|
| 1 | Off | ISO Sensitivity Warning is not displayed. |
| 2 | ISO 400 | ISO Sensitivity Warning is displayed when ISO 400 is reached or exceeded. |
| 3 | ISO 800 | ISO Sensitivity Warning is displayed when ISO 800 is reached or exceeded. |
| 4 | ISO 1600 | ISO Sensitivity Warning is displayed when ISO 1600 is reached or exceeded. |
| 5 | ISO 3200 | ISO Sensitivity Warning is displayed when ISO 3200 is reached. |

- Set in [ISO Snsvtly Wrn Dspl] in the [**C** Custom Setting] menu.
(p.100)

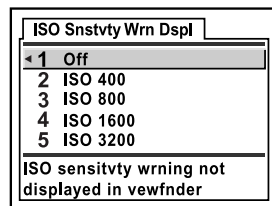

- **ISO** (ISO Sensitivity Warning) appears in the viewfinder when the set sensitivity is set or exceeded.



INFORMATION

- ISO Sensitivity Warning is not displayed if sensitivity is automatically corrected (p.113).

Setting the Recorded Pixels and Quality Level

Setting the Colour Space

- You can set the colour space to use.
The default setting is [sRGB].

| | | |
|---|----------|--------------------------------|
| 1 | sRGB | Sets to sRGB colour space. |
| 2 | AdobeRGB | Sets to AdobeRGB colour space. |

- Set in [Color Space] in the [**C** Custom Setting] menu. (p.99)

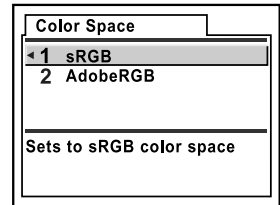

Colour Space

Colour ranges for various input/output devices, such as digital cameras, monitors, and printers, differ.

This colour range is called the colour Space.

To recreate different colour spaces in different devices, standard colour spaces have been proposed. This camera supports sRGB and AdobeRGB.

sRGB is mainly used for devices such as a PC.

AdobeRGB covers a wider area than sRGB and is used for occupational uses such as industrial printing. An image created in AdobeRGB may appear lighter than an image created in sRGB when output from a sRGB compatible device.

Focusing

- You can focus with the following methods.

| | | |
|----|--------------|---|
| AF | Autofocus | The camera is focused when the shutter release button is pressed halfway. |
| MF | Manual focus | Manually adjust the focus. |

- Select the focusing area in the viewfinder (focus point) from [Auto], [Select] and [Center]. (p.120)

Using Autofocus

- You can choose the autofocus mode from **AF,S** (Single mode) where the shutter release button is pressed halfway to focus on the subject and the focus is locked at that position, and **AF,C** (Continuous mode) where the subject is kept in focus by continuous adjustment while the shutter release button is pressed halfway.

1. Set the focus mode lever to **AF**.

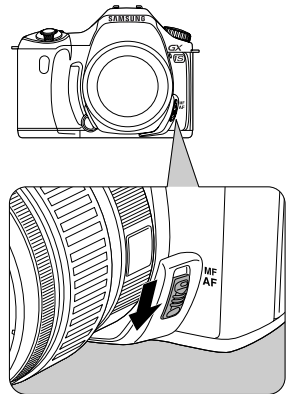

Focusing

2. Look through the viewfinder and press the shutter release button halfway.



- The focus indicator ● appears in the viewfinder when focused (if it is blinking, the subject is not in focus).

※ Hard-to-Autofocus Subjects (p.44)



Focus indicator

INFORMATION

- In **AF.S** (Single mode), the focus is locked (focus lock) while ● is lit. To focus on another subject, take your finger off the shutter release button first.
- During  (Moving Object) mode or when the focus mode is set to **AF.C** (Continuous mode) (p.121), focus is adjusted continuously, tracking the moving object as long as the shutter release button is kept pressed halfway.
- The shutter cannot be released until the subject is in focus in **AF.S** (Single mode). If the subject is too close to the camera, move back and take the picture. Adjust the focus manually if the subject is difficult to focus. (p.44, 124)
- In **AF.S** (Single mode), press the shutter release button halfway. The built-in flash will discharge automatically several times, enabling the autofocus to focus on the subject more easily if the subject is in a dark area and the built-in flash is up.
- Regardless whether the camera is set to **AF.S** (Single mode) or **AF.C** (Continuous mode), the camera automatically tracks the subject if it is deemed to be a moving object.

Focusing

Use the **OK** Button to Focus on the Subject

- You can set the camera so that the focusing is not performed when the shutter release button is pressed halfway and is performed when the **OK** button is pressed. This is useful when you wish to temporarily use autofocus while using manual focus. Set [Enable AF] in [OK btn when shooting] in the [**C** Custom Setting] menu.

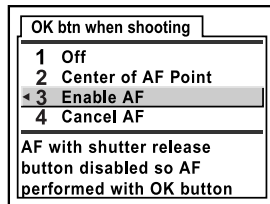

INFORMATION

- Only use this function with lenses that are compatible with Quick Shift Focus.
- Select [Cancel AF]. **MF** appears in the viewfinder while the **OK** button is pressed. Autofocus does not activate when the shutter release button is pressed. This is useful when you wish to temporarily use manual focus while using autofocus.
- You can focus using the focus ring and release the shutter while **OK** button is pressed when using a lens compatible with Quick Shift Focus. (Let go of the **OK** button to immediately return to AF mode.)

Focusing

Setting the AF Mode

- You can choose from the following two autofocus modes. The default setting is **AF.S** (Single mode).

| | | |
|-------------|-----------------|---|
| AF.S | Single mode | When the shutter release button is pressed halfway to focus on the subject, the focus is locked at that position. |
| AF.C | Continuous mode | The subject is kept in focus by continuous adjustment while the shutter release button is pressed halfway. |

- Set [AF Mode] in the [ Rec. Mode] menu (p.96).

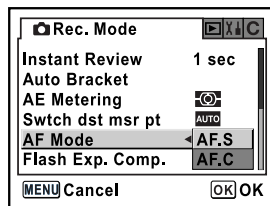



INFORMATION

- Settings cannot be changed in Scene mode (p.45).
- **AF.C** (Continuous mode) can be set when the mode dial is set to **P**, **Tv**, **Av**, **M** or **B** .
The autofocus mode is set to **AF.C** in  (Moving Object) Scene mode.

Focusing

Selecting the Focusing Area (Focus Point)

- Choose the part of the viewfinder to set focus to. The default setting is **AUTO** (Auto). The selected focus point lights red in the viewfinder.

| | | |
|---|--------|--|
|  | Auto | The camera selects the optimum focus point even if the subject is not centred. |
|  | Select | Sets the focusing area to one of the eleven points in the AF area. |
|  | Center | Sets the focusing area to the centre of the viewfinder. |

- Set in [Switch dst msr pt] in the [📷 Rec. Mode] menu (p.96).

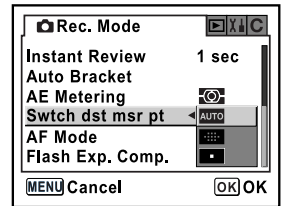



INFORMATION

- Focus point is not displayed in the viewfinder when [Off] is selected for [Superimpose AF Area] in the [C Custom Setting] menu.

Focusing

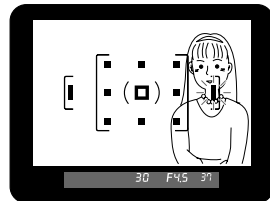

Setting the Focus Position in the Viewfinder

1. Select  (Select) in [Switch dst msr pt] in the [ Rec. Mode] menu.
2. Look through the viewfinder and check the position of the subject.



3. Use the four-way controller () to select the desired focus point.
 - The focus point lights red in the viewfinder (Superimpose AF Area) and you can check where you set the focus point.

INFORMATION

- When [OK btn when shooting] in the [ Custom Setting] menu is set to [Center of AF Point], press the **OK** button to set the focus point to the centre if the focus point other than the center is selected for  (Select).

Focusing

Fixing the Focus (Focus Lock)

- If the subject is outside the range of the focusing area, the camera cannot automatically focus on the subject. In this situation, you can aim the focusing area toward the subject, use focus lock and recompose the picture.

1. Frame the desired composition for your picture in the viewfinder.

- Use the focus lock function when the subject you wish to focus on does not match any of the focus points.

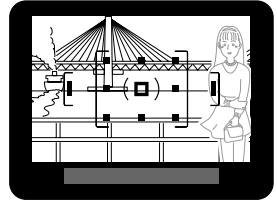

(Example) The person is out of focus and the background is focused instead.

2. Centre the subject to focus in the viewfinder and press the shutter release button halfway.

- The focus indicator ● appears and you will hear a beep when the subject comes into focus (if it is blinking, the subject is not in focus).

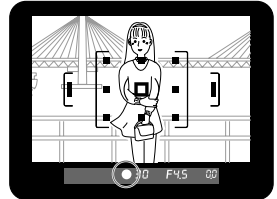

3. Lock the focus.



- Keep the shutter release button pressed halfway. The focus will remain locked.

Focusing

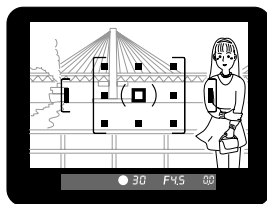
4. Re-compose the picture while keeping the shutter release button pressed halfway.



INFORMATION

- The focus is locked while the focus indicator ● is lit.
- Turning the zooming ring in focus lock mode may cause the subject to be out of focus.
- The beep can be turned off. (p.158)
- You cannot set focus lock when the focus mode is set to **AF.C** (Continuous mode) or the capture mode is set to  (Moving Object). In **AF.C** (Continuous mode) or  (Moving Object) mode, the autofocus continues to focus on the subject until the shutter is released. (Continuous Autofocus)

Fixing Exposure when Focus is Locked

- Set [AE-L with AF locked] in the [C Custom Setting] menu (p.98) to fix the exposure value while focus is locked. Exposure is not fixed by default during focus lock.

| | | |
|---|-----|---|
| 1 | Off | Exposure is not fixed when focus is locked. |
| 2 | On | Exposure is fixed when focus is locked. |

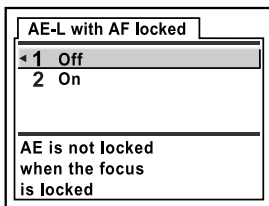

Focusing

Adjusting the Focus Manually (Manual Focus)

- When you adjust the focus manually, you can either check with the focus indicator in the viewfinder or use the viewfinder matte field to adjust focus.

Using the Focus Indicator

- You can manually adjust the focus using the focus indicator ● .

1. Set the focus mode lever to MF .

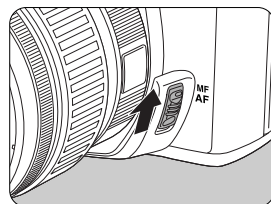

2. Look through the viewfinder, press the shutter release button halfway and turn the focusing ring.

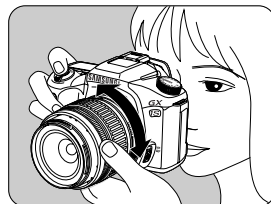

- The focus indicator ● appears and you will hear a beep when the subject comes into focus.

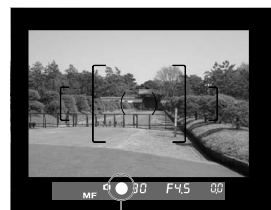

Focus indicator

Focusing

INFORMATION

- Use the matte field in the viewfinder when the subject is difficult to focus (p.44) and the focus indicator will not stay lit.
- The beep can be turned off. (p.158)

Using the Viewfinder Matte Field

- You can manually adjust the focus using the viewfinder matte field.

1. Set the focus mode lever to MF .

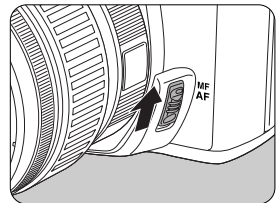

2. Look through the viewfinder and turn the focusing ring until the subject looks sharp on the screen.



Setting the Exposure

Effect of Aperture and Shutter Speed

- Correct exposure of the subject is determined by the combination of shutter speed and aperture setting. There are many correct combinations of shutter speed and aperture for a particular subject. Different combinations produce different effects.

Effect of Shutter Speed

- The shutter speed determines the length of time that light is allowed to strike the CCD. Adjusting the shutter speed alters the amount of light striking the CCD.

- Using slower shutter speed

If the subject is moving, the image will be blurred because the shutter is open longer.

It is possible to enhance the effect of motion (rivers, waterfalls, waves, etc.) by intentionally using a slower shutter speed.

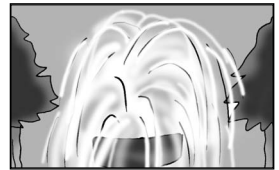

- Using faster shutter speed

Choosing a faster shutter speed will allow freezing the action of a moving subject.

A faster shutter speed also helps preventing camera shake.

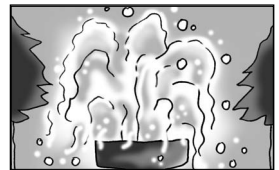

Setting the Exposure

Effect of Aperture

- Adjust the amount of light hitting the CCD by changing the aperture.

- Opening the aperture (reduce the aperture value)

Objects closer and farther than the focused subject will be out of focus. For instance, if you take a picture of flower against a landscape with the aperture open, the landscape in front and behind the flower will be blurred, emphasizing only the flower.

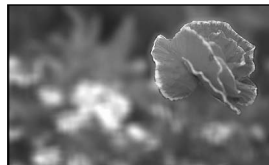

- Closing the aperture (increase the aperture value)

The range in focus expands forward and backward.

For instance, if you take a picture of flower against a landscape with a smaller aperture, the landscape in front and behind the flower will be in focus.



Depth of Field

When you focus on a specific subject, there is a range in which objects closer and farther away will also be in focus. This focused range is called the depth of field.

- The depth of field for the GX-1S differs depending on the lens but compared to a 35 mm camera, the value is roughly one aperture setting lower (the focused range becomes shallower).
- The wider the wide-angle lens, and the farther away the subject, the greater the depth of field (some zoom lenses do not have a scale for depth of field because of their structure).

| | | | |
|-------------------------|-------------------------|----|-------------------------|
| Depth of field | Shallow | ←→ | Deep |
| Area of focus | Narrow | ←→ | Wide |
| Aperture | Open (Smaller value) | ←→ | Close (Larger value) |
| Lens focal length | Longer (Telephoto) | ←→ | Shorter (Wider) |
| Distance to the subject | Near | ←→ | Far |

Setting the Exposure

How to Check Depth of Field

- When you focus on a portion of the subject, there is a range in which object closer and farther will also be in focus. This focused range is called the depth of field. If you use Depth of Field confirmation, you can check the depth of field in the viewfinder before taking a picture.

1. Focus on the subject.

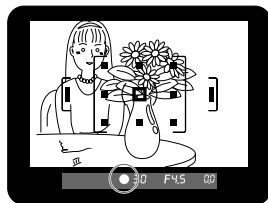

2. Turn the main switch to  while looking through the viewfinder.

- You can check the depth of field in the viewfinder while holding the main switch.

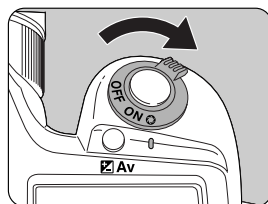







INFORMATION

- No shooting information is displayed in the viewfinder, and the shutter cannot be released while the main switch is in the preview position ().
- You can check the depth of field in all exposure modes.

Setting the Exposure

Selecting the Metering Method

- Choose the part of the screen to use for measuring brightness and determining exposure.  (Multi-segment metering),  (Center-weighted metering) or  (Spot metering) mode can be selected. The default setting is  (Multi-segment metering).

| | | |
|---|--------------------------|--|
|  | Multi-segment metering | Segment the screen in 16 parts, meter each portion and determine the appropriate exposure. |
|  | Center-weighted metering | Measure the entire screen with an emphasis on the center and determine the exposure. |
|  | Spot metering | Measure only the center of the screen and determine exposure. |

- Set in [AE Metering] in the [ Rec. Mode] menu. (p.96)

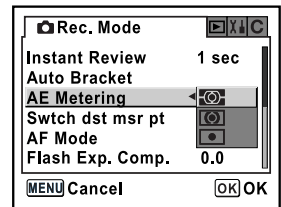

Using the Multi-Segment Metering

- The scene in the viewfinder is metered in 16 different zones as shown in the illustration when using the multi-segment metering. This mode automatically determines what level of brightness is in which portion.

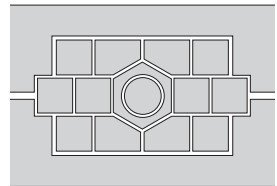

INFORMATION

- The center-weighted metering mode is automatically set even if you select the multi-segment metering mode when using a lens other than the D-XENON lens (can only be used if permission is set in [Using aperture ring] in the [ Custom Setting] menu (p.99)).

Setting the Exposure

Linking AF Point and AE During Multi-Segmented Metering

In [Link AF Point and AE] (p.98) of the [C Custom Setting] menu, you can link the exposure and focus point during multi-segment metering. The default setting is [Off].

| | | |
|---|-----|---|
| 1 | Off | Exposure is set separately from focus point. |
| 2 | On | Exposure is set in accordance with focus point. |

Using the Center-Weighted Metering

- Metering is weighted at the center of the screen.

Use this metering when you want to compensate the exposure by experience, instead of leaving it to the camera.

The illustration shows that sensitivity increases as the pattern height increases (center). This mode does not automatically compensate for backlit scenes.

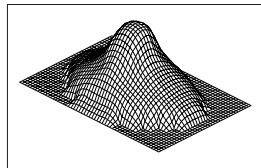

Using the Spot Metering

- With spot metering, brightness is measured only within a limited area at the center of the screen as shown in the illustration.

You can use this in combination with the AE lock (p.141) when the subject is extremely small and proper exposure is difficult to obtain.

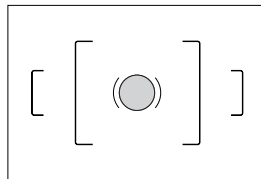

Setting the Exposure

Setting the Meter Operating Time

Set the metering time in [Meter Operating Time] in the [**C** Custom Setting] menu (p.98).
The default setting is [10 sec].

| | | |
|---|-------|-------------------------------------|
| 1 | 10sec | Metering time is set to 10 seconds. |
| 2 | 3sec | Metering time is set to 3 seconds. |
| 3 | 30sec | Metering time is set to 30 seconds. |

Changing the Exposure Mode

- This camera features five exposure modes along with the Scene modes.
Use the mode dial (p.102) to change the exposure mode.

| Exposure Mode | Description | Exposure Compensation | Change Shutter Speed | Change Aperture |
|----------------------------------|--|-----------------------|----------------------|-----------------|
| P (Program) | Automatically sets shutter speed and aperture for taking pictures at the most appropriate exposure. | Yes | No | No |
| Tv (Shutter Priority) | Lets you set a fast shutter speed to 'freeze' moving subjects or a slower shutter speed to show a degree of subject movement in the picture. | Yes | Yes | No |
| Av (Aperture Priority) | Lets you set the appropriate aperture for a maximum or a minimum depth of field. | Yes | No | Yes |
| M (Manual) | Lets you set shutter speed and aperture to create the picture you have in mind. | No | Yes | Yes |
| B (Bulb) | Lets you capture images that require slow shutter speeds such as fireworks and night scenes. | No | No | Yes |

Setting the Exposure

Using the P (Program) Mode

- Shutter speed and aperture values are automatically set for taking pictures at the best average exposure. Perform the following to adjust the exposure.

1. Set the mode dial to **P** .

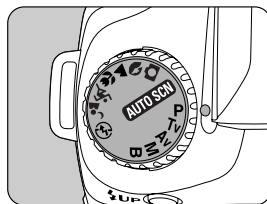

2. Turn the e-dial while pressing the **Av** button and adjust the exposure.

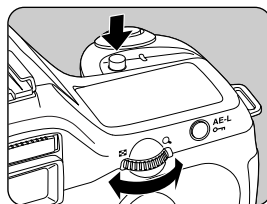

- The EV Compensation is displayed in the viewfinder and on the LCD panel.
- The shutter speed and aperture value are also displayed while adjusting the exposure.



EV Compensation

INFORMATION

- Set EV Compensation in increments of 1/2 EV or 1/3 EV. Set exposure setting steps in [Exposure Setting Steps] in the [C Custom Setting] menu. (p.141)
- You can automatically correct the sensitivity if appropriate exposure cannot be set with the set criteria. Set [Sensitivity] to [AUTO] in the Fn menu. (p.113)

Setting the Exposure

Using the Tv (Shutter Priority) Mode

- Select a fast shutter speed to freeze a moving subject or a slower speed if you want to show some subject movement. The aperture value will automatically adjust to compensate for the change in shutter speed.
- ※ Effect of Aperture and Shutter Speed (p.126)

1. Set the mode dial to **Tv**.

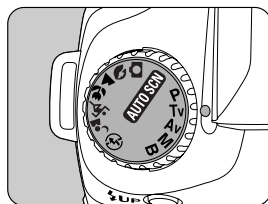

2. Turn the e-dial and adjust the shutter speed.

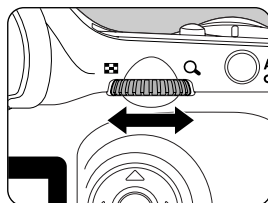

- The shutter speed and aperture value are displayed in the viewfinder and on the LCD panel.



Setting the Exposure

INFORMATION

- Turn the e-dial while pressing the  **Av** button and change the EV Compensation value. (p.140)
- Set the shutter speed in increments of 1/2 EV or 1/3 EV. Set in [Expsr Setting Steps] in the [C Custom Setting] menu. (p.141)
- You can automatically correct the sensitivity if appropriate exposure cannot be set with the set criteria. Set [Sensitivity] to [AUTO] in the Fn menu. (p.113)

Exposure Warning

If the subject is too bright or too dark, the aperture value will blink in the viewfinder and on the LCD panel. If the subject is too bright, choose a faster shutter speed. If it is too dark, choose a slower shutter speed. When the aperture value indication stops blinking, you can take the picture with proper exposure.

If both the shutter speed and aperture value are blinking, this indicates being out of metering range and the proper exposure cannot be obtained even if the shutter speed is adjusted.

Use an ND (Neutral Density) filter if the subject is too bright.

Use a flash if it is too dark.



Setting the Exposure

Using the **Av** (Aperture Priority) Mode

- Set a suitable aperture when you want to control the depth of field. The depth of field is greatest when using a smaller aperture (larger number). Using a larger aperture (smaller number) gives the minimum depth of field.
The shutter speed is automatically changed to the appropriate setting depending on the size of aperture selected.
- ※ Effect of Aperture and Shutter Speed (p.126)

1. Set the mode dial to **Av** .

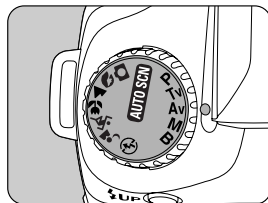

2. Turn the e-dial and adjust the aperture value.

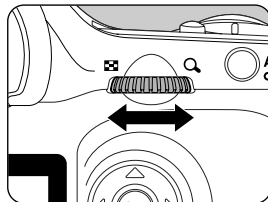

- The shutter speed and aperture value are displayed in the viewfinder and on the LCD panel.

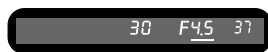

Setting the Exposure

INFORMATION

- Turn the e-dial while pressing the  Av button and change the EV Compensation value.
- Set the aperture value in increments of 1/2 EV or 1/3 EV. Set in [Expsr Setting Steps] in the [C Custom Setting] menu. (p.141)
- You can automatically correct the sensitivity if appropriate exposure cannot be set with the set criteria. Set [Sensitivity] to [AUTO] in the Fn menu. (p.113)

Exposure Warning

If the subject is too bright or too dark, the shutter speed will blink in the viewfinder and on the LCD panel. If the subject is too bright, set the aperture

smaller (larger number), and when too dark, open the aperture further (smaller number).

Once blinking stops, you can take the picture.

If both the shutter speed and aperture value are blinking, this indicates being out of metering range and the proper exposure cannot be obtained even if the aperture is adjusted.

Use an ND (Neutral Density) filter if the subject is too bright.

Use a flash if it is too dark.



Setting the Exposure

Using M (Manual) Mode

- You can set the shutter speed and aperture values manually.
This mode is convenient for taking pictures using shutter speed and aperture settings for taking intentionally under-exposed (darker) or over-exposed (brighter) photographs.
- ※ Effect of Aperture and Shutter Speed (p.126)

1. Set the mode dial to **M** .

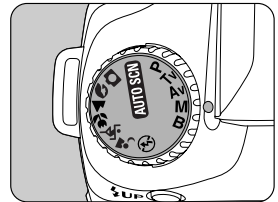

2. Turn the e-dial and adjust the shutter speed.

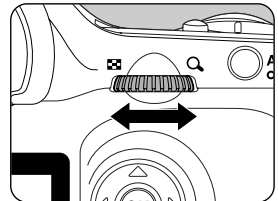

3. Turn the e-dial while pressing the **Av** button and adjust the aperture.

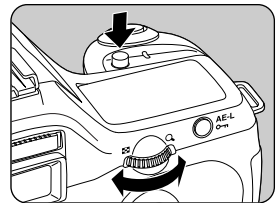

Setting the Exposure

- The shutter speed and aperture value are displayed in the viewfinder and on the LCD panel.

The value of the shutter speed or aperture being adjusted is underlined in the viewfinder. While adjusting the shutter speed or aperture value, the difference in the appropriate exposure (EV value) appears at the bottom right of the viewfinder. The appropriate exposure is set when [0.0] is displayed.



Difference from the appropriate exposure

INFORMATION

- When in **M** (Manual) mode, the sensitivity is equivalent to ISO 200 when sensitivity is set to [AUTO].
- Blinks when the difference with appropriate exposure is over ± 3.0 .
- Set the shutter speed and aperture values in increments of 1/2 EV or 1/3 EV. Set in [Expsr Setting Steps] in the [C Custom Setting] menu. (p.141)

Exposure Warning

You are out of the measuring area if the shutter speed and aperture blink. Use an ND (Neutral Density) filter if the subject is too bright. Use a flash if it is too dark.



Setting the Exposure

About the AE-L Button

The aperture and shutter speed are automatically adjusted to the appropriate exposure at that moment if the **AE-L** button is pressed in **M** (Manual) mode. You can choose from the following three adjustment methods in [AE-L btn on M expsr] in the [**C** Custom Setting] menu.

| | | |
|---|--------------|---|
| 1 | Program Line | The aperture and shutter speed are adjusted automatically. |
| 2 | Tv Shift | The aperture is locked and the shutter speed is adjusted automatically. |
| 3 | Av Shift | The shutter speed is locked and the aperture is adjusted automatically. |

Using the **B** (Bulb) Mode

- This mode is useful when long exposures are needed for shooting night scenes or firework displays. The shutter remains open as long as the shutter release button is kept pressed.

1. Set the mode dial to **B** .

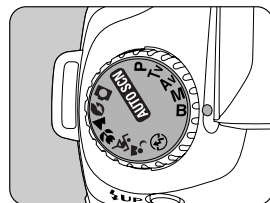

INFORMATION

- Turn the e-dial to adjust the aperture value.
- Set the aperture value in increments of 1/2 EV or 1/3 EV. Set in [Expsr Setting Steps] in the [**C** Custom Setting] menu. (p.141)
- Use a sturdy tripod and the cable switch SSR-D1 (optional) to prevent camera shake when using **B** (Bulb) mode. Connect the cable switch to the cable switch terminal.
- Bulb shooting is available when using the remote control shooting mode (p.57). The shutter remains open as long as the remote control shutter release button is held down.
- Noise reduction is a process to reduce noise (image roughness or unevenness) caused by low shutter speed. Set in [Noise Reduction] in the [**C** Custom Setting] menu. (p.98)
- When in **B** (Bulb) mode, the sensitivity is equivalent to ISO 200 when sensitivity is set to [AUTO].

Setting the Exposure



Setting the Exposure

- This allows you to deliberately over-expose (brighten) or under-expose (darken) your picture. You can adjust the EV Compensation from -2 to +2 (EV) in increments of 1/2 EV or 1/3 EV. Set in [Expsr Setting Steps] in the [C Custom Setting] menu. (p.141)

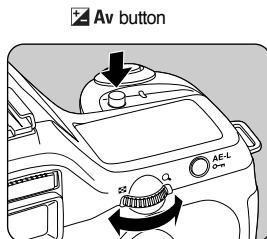
1. Set the compensation with the e-dial while the  **Av** button is pressed.



2. Confirm the compensation value in the viewfinder.

-  is displayed during compensation.
-  blinks when the flash is popped up if the flash compensation is set.



Compensation value

INFORMATION

- Exposure compensation is not available when the exposure mode is set to **M** (Manual) or **B** (Bulb) mode.
- The exposure compensation cannot be cancelled by turning the camera off or by setting any other exposure mode.

Setting the Exposure

Changing the Exposure Setting Steps

- Set Exposure Setting Steps in [Expsr Setting Steps] in [C Custom Setting] to increments of 1/2 EV or 1/3 EV.

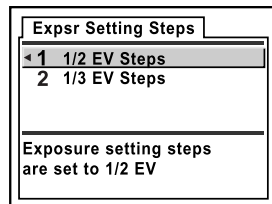

Recording the Exposure Before Shooting (AE Lock)

- AE Lock is a function that memorizes the exposure prior to taking the picture. Use this when the subject is too small or backlit and a proper exposure setting cannot be obtained.

1. Press the **AE-L** button.

- The camera memorizes the exposure (brightness) at that instant.

Press it again to unlock.

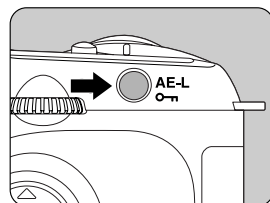

INFORMATION

- * is displayed in the viewfinder while the AE lock is engaged. (p.18)
- The exposure remains in memory for twice as much time as the metering timer after releasing the **AE-L** button. The exposure remains locked as long as the **AE-L** button is kept pressed or the shutter release button is kept pressed halfway.
- You will hear a beep when the **AE-L** button is pressed. The beep can be turned off. (p.158)
- AE lock is not available when the exposure mode is **M** (Manual) or **B** (Bulb) mode.
- The combination of shutter speed and aperture value changes depending on the zooming position even while the AE lock is engaged when using a zoom lens for which maximum aperture varies depending on the focal length. However, the exposure value does not change and the picture is taken at the brightness level set by the AE lock.
- If the exposure mode is **M** (Manual), the aperture and/or shutter speed are automatically adjusted to set the appropriate exposure when the **AE-L** button is pressed. (p.137)
- Exposure can be fixed when focus is locked. Set in [AE-L with AF locked] in the [C Custom Setting] menu. (p.123)

Setting the Exposure

Changing the Exposure and Shooting (Auto Bracket)

- You can take continuous pictures with different exposure when the shutter release button is pressed. The first frame is exposed with no compensation, the second frame is under-exposed (negative compensation) and the third is over-exposed (positive compensation).



[Normal exposure]



[Under-exposure]



[Over-exposure]

1. Press the **Fn** button in capture mode.
- The Fn menu appears.

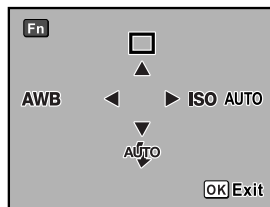

2. Press the four-way controller (**▲**).
- The Drive Mode options screen appears.

3. Use the four-way controller (**▶**) to select  (Auto Bracket).

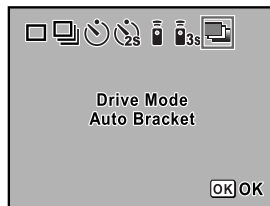

Setting the Exposure

4. Press the **OK** button twice.

- Shooting is ready and  is displayed on the LCD panel.

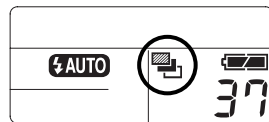

5. Press the shutter release button halfway.

- Focus indicator  appears in the viewfinder when focused.

6. Press the shutter release button fully.

- Three consecutive pictures will be taken, the first with no compensation, the second with negative compensation, and the third with positive compensation.

INFORMATION

- When the focus mode is set to **AF,S** (Single mode), the focus is locked in the first frame position and used for subsequent consecutive frames.
- The auto bracketing exposure setting will remain effective for twice as long as the exposure metering timer (default setting is 20 seconds) when you release your finger from the shutter release button during auto bracketing, and you can take the next picture at the next compensation value.
In this case, auto focusing works for each frame. After about twice as much time as the exposure metering timer (default setting is 20 seconds), the camera returns to settings for taking the first picture.
- You can combine Auto Bracket with the built-in flash or external flash (P-TTL auto only) to change only the flash output continuously. However, when using an external flash, holding the shutter release button down to take three continuous frames may cause the second and third frame to be taken before the flash is fully recharged. Always take one frame at a time after confirming that charging is complete.
- Auto Bracket is not available when the exposure mode is set to **B** (Bulb) mode.

Setting the Exposure

Setting Auto Bracket

- Change the shooting order and steps of Auto Bracket.

| | | |
|--------------------------------------|--------|--|
| Bracketing amount (Step interval) | 1/2 EV | $\pm 0.5, \pm 1.0, \pm 1.5, \pm 2.0$ |
| | 1/3 EV | $\pm 0.3, \pm 0.7, \pm 1.0, \pm 1.3, \pm 1.7, \pm 2.0$ |
| Shooting images | | 0 → - → +, - → 0 → +, + → 0 → - |

※ Set interval of steps in [Expsr Setting Steps] in the [**C** Custom Setting] menu. (p.141)

- Set in [Auto Bracket] in the [**📷** Rec. Mode] menu. (p.96)

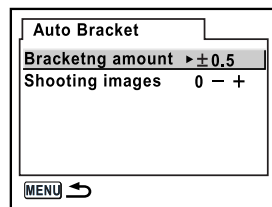

Taking Only Over-exposed or Under-exposed Pictures

You can use the auto bracketing mode for only under-exposure or over-exposure shots by combining the operation with exposure compensation (p.140). The auto bracketing is performed in both cases on the basis of the specified exposure compensation value.

Using the Built-in Flash

Compensating Flash Output

- You can change the flash output in a range of -2.0 to +1.0. The Flash Compensation values are as follows for 1/2 EV and 1/3 EV.

| Step interval | Flash Compensation |
|---------------|---|
| 1/2 EV | -2.0, -1.5, -1.0, -0.5, 0.0, +0.5, +1.0 |
| 1/3 EV | -2.0, -1.7, -1.3, -1.0, -0.7, -0.3, 0.0, +0.3, +0.7, +1.0 |

※ Set interval of steps in [Expsr Setting Steps] in the [**C** Custom Setting] menu. (p.141)

- Set in [Flash Exp. Comp.] in the [**Rec. Mode**] menu. (p.96)

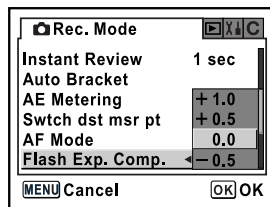

INFORMATION

-  blinks in the viewfinder when the flash pops up during Flash Compensation. (p.18)
- If the maximum flash output is exceeded when corrected to the plus (+) side, no compensation will be effective.
- Compensating to the minus (-) side may not effect the image if the subject is too close, aperture is low or sensitivity is high.

Using the Built-in Flash

Allowing Shooting while Charging Flash

- You can set to enable shooting while flash is being charged.
Set [On] for [Release when Charging] in the [**C** Custom Setting] menu (p.99). Pictures cannot be taken while the flash is charging by default.

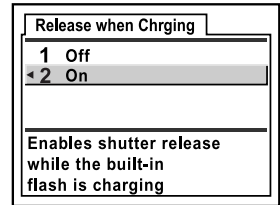

Flash Characteristics in Each Exposure Mode

- Using the Flash in Tv (Shutter Priority) Mode
 - When taking a moving subject, you can use the flash to change the blur effect.
 - Any desired shutter speed 1/180 sec. or slower can be set for taking a flash photograph.
 - The aperture value automatically changes according to the ambient brightness.
- Using the Flash in Av (Aperture Priority) Mode
 - You can set the desired aperture to take a flash photograph when you want to change the depth of field or shoot a subject farther away.
 - The shutter speed automatically changes with the ambient brightness.
 - The shutter speed shifts automatically anywhere from 1/180 sec. to a slow shutter speed that reduces camera shake. The slowest shutter speed depends on the focal length of the lens in use.

Using the Built-in Flash

Using Slow-Speed-Sync

- You can use slow-speed-sync when shooting portraits with the sunset in the background.

INFORMATION

- Slow-speed-sync slows the shutter speed. Use a tripod to avoid camera shake. The picture will also blur if the subject moves.
 - Slow-speed-sync shooting can also be performed with an external flash.
-
- Using **Tv** (Shutter Priority) Mode
 1. Set the mode dial to **Tv** .
Tv (Shutter Priority) mode is set.
 2. Use the e-dial to set the desired shutter speed.
The background is not properly corrected if aperture value is flashing when shutter speed is set. Set the shutter speed so that aperture does not flash.
 3. Press the **⚡UP** button.
The flash pops up.
 4. Take the picture.

 - Using **M** (Manual) Mode
 1. Set the mode dial to **M** .
M (Manual) mode is set.
 2. Set the shutter speed (under 1/180 sec.) and aperture value to obtain correct exposure.
 3. Press the **⚡UP** button.
The flash pops up.
In **M** (Manual) mode, pop up the flash at any time.
 4. Take the picture.

Using the Built-in Flash

Distance and Aperture when Using the Built-in Flash

- A set criteria is necessary between the guide number, aperture and distance when shooting with the flash. Calculate and adjust the shooting conditions if flash is not sufficient.
- Built-in flash guide number

| Sensitivity | Built-in flash guide number |
|-------------|-----------------------------|
| ISO 200 | 15.6 |
| ISO 400 | 22 |
| ISO 800 | 31 |
| ISO 1600 | 44 |
| ISO 3200 | 62 |

Calculating Shooting Distance from Aperture Value

- The following equation calculates the distance of the flash for aperture values.

Maximum flash distance $L1 = \text{Guide number} \div \text{Selected aperture}$

Minimum flash distance $L2 = \text{Maximum flash distance } L1 \div 5^*$

* The value 5 used in the formula above is a fixed value which applies only when using the built-in flash alone.

Example)

When sensitivity is [ISO 200] and aperture value is F4

$L1 = 15.6 \div 4 = \text{approx. } 3.9 \text{ (m)}$

$L2 = 3.9 \div 5 = \text{approx. } 0.8 \text{ (m)}$

Therefore, the flash can be used in a range of about 0.8 m to 3.9 m.

The flash cannot be used when the distance is less than 0.7 m. When the flash is used at closer than 0.7 m, it causes vignetting in the picture corners, light is distributed unevenly and the picture may be over-exposed.

Using the Built-in Flash

Calculating Aperture Value from Shooting Distance

- The following equation calculates the aperture value for shooting distances.

Aperture Value Used $F = \text{Guide number} \div \text{Shooting distance}$

When sensitivity is [ISO 200] and shooting distance is 5.2 m, aperture value is:

$$F = 15.6 \div 5.2 = 3$$

If the resulting number (3, in the above example) is not available as a lens aperture, the smaller number that is closest (2.8, in the above example) is generally used.

Using an External Flash (Optional)

- Using the optional external flash SEF-36PZF enables a variety of flash modes, such as P-TTL auto flash mode, high-speed flash sync mode, and wireless mode. See the chart below for details.
(Yes: Available - #: Restricted - No: Not available)
- See the SEF-36PZF operating manual for details.
- ※ When using an external flash, it is recommended to use the high-precision SEF-36PZF, as it is capable of P-TTL auto flash mode.

| Camera Function | Flash | Built-in Flash | SEF-36PZF |
|---|-------|----------------|-----------|
| Red-eye reduction flash | | Yes | Yes |
| Automatic flash discharge | | Yes | Yes |
| After the flash is charged, the camera automatically switches to the flash sync speed. | | Yes | Yes |
| Aperture is automatically set in P (Program) mode and Tv (Shutter Priority) mode. | | Yes | Yes |
| P-TTL auto flash (appropriate sensitivity: 200 to 3200) | | Yes | Yes |
| Slow-speed sync | | Yes | Yes |
| Flash exposure compensation | | Yes | Yes |
| AF illuminator | | Yes | Yes |
| Rear curtain sync flash*1 | | # *2 | Yes |
| Contrast-control-sync flash mode | | # *3 | Yes |
| Slave flash | | No | Yes |
| High-speed flash sync | | No | Yes |
| Wireless flash*4 | | No | Yes |

*1 : Shutter speed of 1/90 sec. or slower.

*2 : Can be combined with SEF-36PZF for rear curtain sync flash.

*3 : When combined with the SEF-36PZF, 1/3 of the flash discharge can be output by the built-in flash and 2/3 can be output by the external flash.

*4 : Two or more SEF-36PZF units are required.

Using an External Flash (Optional)

About the LCD Panel Display for SEF-36PZF

- The SEF-36PZF will automatically convert the field angle differential between 35 mm format and the GX-1S depending on the focal length of the lens you are using (when using D-XENON lenses). The conversion indicator appears and the format size indicator disappears when the exposure metering timer of the GX-1S is on (it returns to 35 mm format display when the exposure metering timer is turned off).



| Lens focal length | | 85mm | 77mm | 50mm | 35mm | 28mm | 24mm | 20mm | 18mm |
|-------------------|-----------------------------|------|------|------|------|------|-------|------|------|
| SEF-36PZF | Exposure metering timer Off | 85mm | 70mm | 50mm | 35mm | 28mm | 24mm* | | |
| LCD panel | Exposure metering timer On | 58mm | 48mm | 34mm | 24mm | 19mm | 16mm* | | |

* Using wide adaptor

Using P-TTL Auto Mode

- Use this flash mode with the SEF-36PZF flash unit. When flash mode is set to “P-TTL auto”, the flash pre-fires right before taking pictures using 16-segment metering and allows more precise control. P-TTL auto is available in wireless flash mode when two or more SEF-36PZF units are used.
 1. Remove the cover of the hot shoe and attach the SEF-36PZF.
 2. Turn on the SEF-36PZF.
 3. Set the SEF-36PZF flash mode to P-TTL auto.
 4. Confirm that the SEF-36PZF is fully charged and then take the picture.

INFORMATION

- P-TTL auto is only available with the SEF-36PZF flash unit.
- The  will light in the viewfinder when the flash is ready (fully charged).
- For details such as operation method and effective distance, please read the external flash manual.
- The flash does not discharge when the subject is bright enough when Flash Mode is  or . Therefore, it may not be suitable for daylight-sync shooting.
- Never press the flash pop up button when any external flash unit is attached to the camera. The built-in flash will hit the external flash.
- See the SEF-36PZF operating manual for details.

Using an External Flash (Optional)

Using High-Speed Flash Sync Mode

- With the SEF-36PZF, you can discharge the flash to take a picture at a shutter speed faster than 1/180 second. High-speed flash sync can be used with the flash attached to the camera, or wireless.
- Attaching and Using the SEF-36PZF on the Camera
 1. Remove the hot shoe cover and attach the SEF-36PZF.
 2. Turn the mode dial and set the exposure mode to **Tv** or **M**.
 3. Turn on the SEF-36PZF.
 4. Set the SEF-36PZF sync mode to HS (high-speed flash sync.).
 5. Confirm that the SEF-36PZF is fully charged and then take the picture.

INFORMATION

- The  will light in the viewfinder when the flash is ready (fully charged).
- High-speed flash sync is only available when the shutter speed is faster than 1/180 sec.
- High-speed flash sync is not available when the exposure mode is set to **B** (Bulb).
- See the SEF-36PZF operating manual for details.

Using in Wireless Mode

- Shoot using the flash without connecting the camera and flash with a cord by using two SEF-36PZF units. The High-speed sync mode is also available in wireless mode.

INFORMATION

- Be sure to set the two SEF-36PZF units to the same channel. See the SEF-36PZF operating manual for details.

Using an External Flash (Optional)

- In Wireless Mode

1. Place the SEF-36PZF at the desired location.
2. Set the SEF-36PZF power switch to [WIRELESS].
3. Set the SEF-36PZF wireless mode to S (Slave).
4. Turn the camera mode dial and set the exposure mode to **P**, **Tv**, **Av** or **M** mode.
5. Set the SEF-36PZF power switch on the camera to [WIRELESS].
6. Set the SEF-36PZF wireless mode on the camera to **M** (Master) or **C** (Control).

INFORMATION

- Wireless mode is not available for the built-in flash.
- Set the SEF-36PZF wireless slave mode to SLAVE1.
- See the SEF-36PZF operating manual for details.

Wireless Flash Control (P-TTL Flash Mode)

The following information is exchanged between the two SEF-36PZF flash units before the flash is discharged when the SEF-36PZF is used for wireless flash.

Press the shutter release button fully.

1. The camera's flash discharges a pre-flash (the camera's flash mode is transmitted).
2. The external flash unit discharges a pre-flash (the subject's lighting condition is checked).
3. The camera's flash unit discharges a pre-flash (the required flash output is transmitted to the external flash).
 - ※ The camera's flash will discharge another pre-flash to transmit the flash duration in HS ⚡ (High-speed sync).
4. The external flash discharges the main flash.
 - ※ Set the SEF-36PZF wireless slave mode to SLAVE1.

Using an External Flash (Optional)

Red-Eye Reduction

- As with the built-in flash, red-eye reduction is available with an external flash.

INFORMATION

- The red-eye reduction feature works even when only an external flash is used. (p.50)
- If red-eye reduction is used when the SEF-36PZF is set as the slave unit or with the wireless function, the preflash for red-eye reduction will trigger the external flash. Do not use red-eye reduction when using a slave unit.
- See the SEF-36PZF operating manual for details.

Settings During Playback

Changing Playback Display Method

- Set information to show during playback.
The camera switches display information when you press **INFO** button.

| | |
|---------------------|--|
| Images only | Only captured images are displayed. |
| Image+Histgrm | Images and histogram are displayed. |
| Image+Detailed Info | Image details appear with a small image in the upper left. |
| Last memory | Display settings are retained from previous session. |

- Set in [Plybk dsply mthd] in the [ Playback] menu. (p.96)

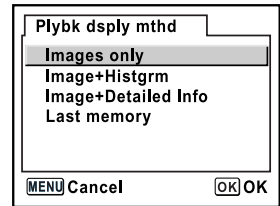

- ※ Refer to p.16 for various display information details.

Displaying Bright Portion Warning

- If [Instant Review] or [Instnt review+Plybck] in [Bright Portion] is selected, bright areas (over exposed areas) in the image blink on the Instant Review and playback screens.
The default setting is [OFF].

| | |
|----------------------|--|
| OFF | Turn off the bright portion warning. |
| Instant Review | Over exposed area warning is displayed only during Instant Review. |
| Instnt review+Plybck | Over exposed area warning is displayed during Instant Review and playback. |

Settings During Playback

- Set in [Bright Portion] in the [▶ Playback] menu. (p.96)

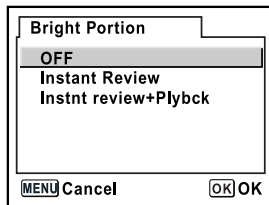

Setting the Slideshow Display Interval

- You can play back all images recorded on your SD Memory Card successively. (p.66)
Set image display interval to [3 sec], [5 sec], [10 sec] or [30 sec].
The default setting is [3 sec].
Set in [Slideshow] in the [▶ Playback] menu (p.96).

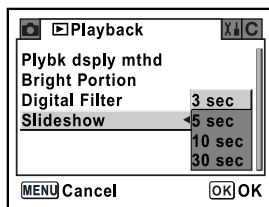

※ After setting, press the **OK** button to start slideshow.

Camera Settings

Formatting the SD Memory Card

- Be sure to format new SD Memory Card with the camera before using the card. Formatting will delete all the data on the SD Memory Card.

INFORMATION

- Do not open the card cover while formatting SD Memory Card. The card may be damaged beyond use.
- Formatting will delete protected data. Be aware.

1. Select [Format] on the [X↓ Set-up] menu (p.97).
2. Press the four-way controller (▶) to display the Format screen.
3. Use the four-way controller (▲) to select [Format].

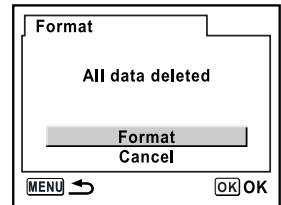

4. Press the **OK** button.
Formatting starts. When formatting is completed, the camera is ready to take pictures.

Camera Settings

Turning the Beep On and Off

- You can turn the camera operation beep on or off.
The default setting is [On].
Set in [Beep] in the [X] Set-up] menu. (p.97)

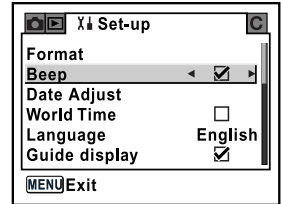

Changing the Date and Time and the Display Style

- You can change the initial date and time settings.
You can also set the display style. Choose [mm/dd/yy], [dd/mm/yy] or [yy/mm/dd]. Choose [12h (12 hour)] or [24h (24 hour)] for time display method.
- Setting the Date and Time (p.33)

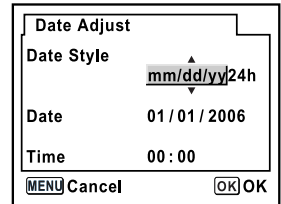

Camera Settings

Setting the World Time

- The date and time selected in "Initial Settings" (p.31) serve as the date and time of your present location.

Setting [World Time] enables you to display the local date and time on the LCD monitor when travelling overseas.

1. Select [World Time] on the [X↓ Set-up] menu. (p.97)

2. Press the four-way controller (▶).

The World Time screen appears.

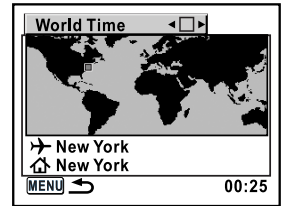

3. Use the four-way controller (◀▶) to select (On) or (Off).

| | |
|-------------------------------------|---|
| <input checked="" type="checkbox"/> | Applies time of city set in ✈ (Destination) |
| <input type="checkbox"/> | Applies time of city set in 🏠 (Hometown) |

4. Press the four-way controller (▼).

The selection frame moves to ✈ . The city with ✈ blinks.

5. Press the four-way controller (▶).

The screen for magnifying the Destination region appears.

Use the four-way controller (◀▶) to magnify the region.

6. Press the four-way controller (▼).

The frame moves to city.

Camera Settings

7. Use the four-way controller (◀▶) to select the Destination city.
The current time, location and time difference of the selected city appears.

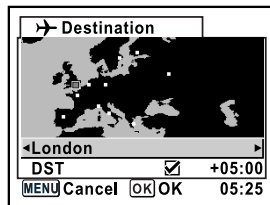

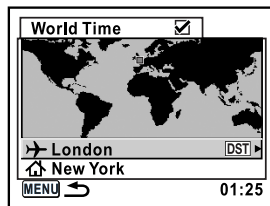

8. Use the four-way controller (▼) to select [DST].
9. Use the four-way controller (◀▶) to select (On) or (Off).
Select (On) if the Destination city uses daylight saving time (DST).

10. Press the **OK** button.
The World Time setting is saved.
To continue with World Time setting operations, press the **OK** button to return to the World Time screen.



11. Press the **MENU** button twice.
The camera is ready to take pictures.

INFORMATION

- See “List of World Time Cities” (p.161) for cities that can be specified as a destination.
- Select  in Step 4 to set the city and DST setting.
-  appears on the guide display screen if World Time is On (). (p.14)

Camera Settings

List of World Time Cities

| Region | City |
|---------------------------|----------------------|
| North America | Honolulu |
| | Anchorage |
| | Vancouver |
| | San Francisco Dubai |
| | Los Angeles |
| | Calgary |
| | Denver |
| | Chicago |
| | Miami |
| | Toronto |
| | New York |
| | Halifax |
| Central and South America | Mexico City |
| | Lima |
| | Santiago |
| | Caracas |
| | Buenos Aires |
| | Sao Paulo |
| | Rio de Janeiro |
| Europe | Madrid |
| | London |
| | Paris |
| | Amsterdam |
| | Milan |
| | Rome |
| | Berlin |
| | Stockholm |
| | Athens |
| | Helsinki |
| | Moscow |
| | Africa/ West Asia |
| Algiers | |
| Johannesburg | |
| Istanbul | |
| Cairo | |
| Jerusalem | |

| Region | City |
|----------------------|--------------|
| Africa/ West Asia | Nairobi |
| | Jeddah |
| | Tehran |
| | Dubai |
| | Karachi |
| | Kabul |
| | Male |
| | Delhi |
| | Colombo |
| | Katmandu |
| Dacca | |
| East Asia | Yangon |
| | Bangkok |
| | Kuala Lumpur |
| | Vientiane |
| | Singapore |
| | Phnom Penh |
| | Ho Chi Minh |
| | Jakarta |
| | Hong Kong |
| | Beijing |
| | Shanghai |
| | Manila |
| | Taipei |
| | Seoul |
| Tokyo | |
| Guam | |
| Oceania | Perth |
| | Adelaide |
| | Sydney |
| | Noumea |
| | Wellington |
| | Auckland |
| Pago Pago | |

Camera Settings

Setting the Display Language

- You can change the language in which the menus, error messages, etc. are displayed.

Set in [Language] in the [Set-up] menu. (p.97)

You can choose from eleven languages: English, French, German, Spanish, Italian, Swedish, Dutch, Russian, Korean, Chinese (Traditional/ Simplified) and Portuguese.

- Setting the Display Language (p.31)

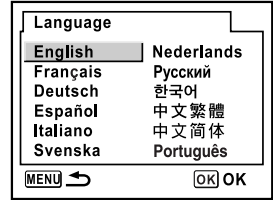

Turning the Guide Display On and Off

- Set to display guides on the LCD monitor when main switch is on or Exposure mode is changed. (p.14)

| | |
|-------------------------------------|-------------------|
| <input checked="" type="checkbox"/> | Guide display on |
| <input type="checkbox"/> | Guide display off |

- Set in [Guide display] in the [Set-up] menu. (p.97)

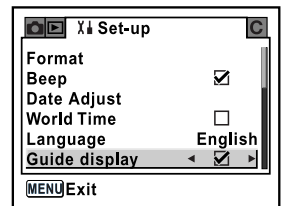

Camera Settings

Adjusting the Brightness of the LCD Monitor

- You can adjust the brightness of the LCD monitor.
Adjust settings when the LCD monitor is hard to see.
Set in [Brightness Level] in the [ Set-up] menu. (p.97)

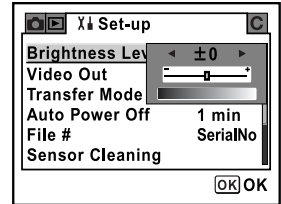

Selecting the Video Output Format

- When you connect the camera to AV equipment such as a TV, choose the appropriate video output format (NTSC or PAL) for playing back images.
Set in [Video Out] in the [ Set-up] menu. (p.97)
- Connecting the Camera to AV Equipment (p.68)

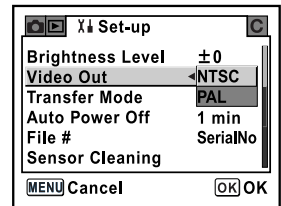

INFORMATION

- The video output format varies according to region. The video output format used in North America is NTSC.

Camera Settings

Setting Auto Power Off

- You can set the camera to turn off automatically if unused after a certain length of time.
Select from [1 min], [3 min], [5 min], [10 min], [30 min] or [Off].
The default setting is [1 min].
Set in [Auto Power Off] in the [\times ↓ Set-up] menu. (p.97)

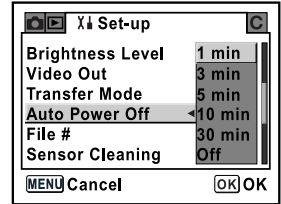

INFORMATION

- Auto Power Off will not work during slideshow playback, a USB connection, remote control shooting or while displaying menu or Fn menu.

Resetting the File Number

- You can set the File Number used for the images when inserting a new SD Memory Card.
The default setting is [SerialNo].

| | |
|----------|---|
| SerialNo | The file number for the most recently captured image is placed in memory and the file number will remain continuous after inserting the new SD Memory Card. |
| Reset | Every time a new SD Memory Card is inserted, the file number is the smallest number. When an SD Memory Card with stored images is inserted, numbering continues from the last stored file number. |

- Set in [File #] in the [\times ↓ Set-up] menu. (p.97)

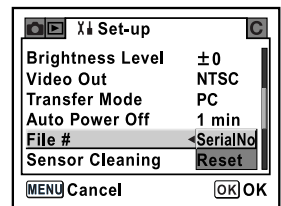

Camera Settings

Setting the Display Time

- Select from [1 sec], [3 sec], [5 sec] or [Off]. The default setting is [1 sec].
Set in [Instant Review] in the [ Rec. Mode] menu. (p.96)

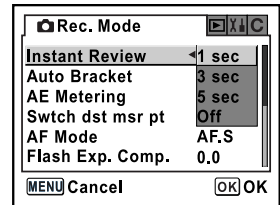

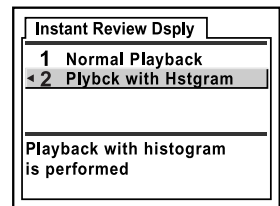

Displaying Histogram During Instant Review

- Set to display histogram during Instant Review.
Select [Plybck with Hstgram] in [Instant Review Dsply] in the [ Custom Setting] menu. (p.99)
The default setting is to not display histogram.





Resetting to Default Settings

Resetting Rec. Mode/ Playback/ Set-up Menu

- Settings in [ Rec. Mode] menu, [ Playback] menu and [ ↓ Set-up] menu are reset to default settings.

However, Date Adjust, Language, Video Out and World Time are not reset.

1. Select [Reset] on the [ ↓ Set-up] menu.
2. Press the four-way controller () to display the [Reset] screen.
3. Use the four-way controller () to select [Reset].

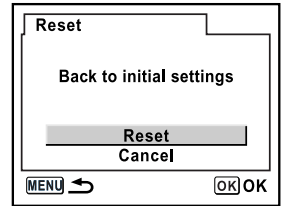

4. Press the **OK** button.
The camera is ready to take or play back images.

Resetting to Default Settings

Resetting the Custom Function Menu

- Reset settings in [**C** Custom Setting] menu to default settings.
Settings in [**REC** Rec. Mode] menu, [**PLAY** Playback] menu and [**X** Set-up] menu are not reset.

1. Select [Reset] on the [**C** Custom Setting] menu.
2. Press the four-way controller (▶) and display the Reset Custom Fncion screen.
3. Use the four-way controller (▲) to select [Reset].

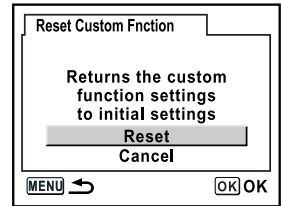

4. Press the **OK** button.
The camera is ready to take or play back images.

MEMO

A large, empty rectangular box with rounded corners, intended for writing a memo. The box is outlined in a thin gray border and occupies most of the page below the header.

6 Software information

Explains software installation and how to use the program.

| | |
|---|-----|
| Software Notes | 170 |
| About the software | 171 |
| Setting up the application software | 172 |
| Starting PC mode | 173 |
| Removable Disk | 174 |
| Removing the removable disk | 176 |
| Digimax Master | 178 |

Software Notes

Please ensure that you read this section of the instruction manual carefully before use.

- The included software is a camera driver and image editing software tool for Windows.
- Under no circumstances should all or part of either the software or the user manual be reproduced.
- Copyrights for software are licensed only for use with a camera.
- In the unlikely event of a manufacturing fault, we will repair or exchange your camera.
We cannot, however, be held responsible in any way for damage caused by inappropriate use.
- Using a Hand-made PC or a PC and OS that has not been guaranteed by the manufacturer is not covered by the Samsung warranty.
- Before reading this manual, you should have a basic knowledge of computers and O/S (Operating Systems).

System Requirements

| For Windows | For Macintosh |
|--|---|
| PC with processor better than Pentium III 450Mz (Pentium 700MHz recommended) | Power Mac G3 or later |
| Windows 2000/ME/XP | Mac OS 9.0 or later |
| Minimum 256MB RAM (XP : 512MB) 250MB of available hard disk space (1GB recommended) | Minimum 256MB RAM 250MB of available hard-disk space |
| USB port | USB port |
| CD-ROM drive | CD-ROM drive |
| 1024x768 pixels, 16-bit colour display compatible monitor (24-bit colour display recommended) | |

About the software

- Digimax Master : This is the all-in-one multi media software solution
You can download, view, edit and save your digital images (RAW, JPEG) with this software. This software is only compatible with Windows.

INFORMATION

- You should allow 5~10 seconds for running the automatic setup program according to the capability of your computer. If the frame does not show, run the [Windows Explorer] and select [setup.exe] in the CD-ROM Drive root directory.
- PDF documents of user manual are included in the Software CD-ROM supplied with this camera. Search the PDF files with Window' s explorer. Before opening the PDF files, you must install the Adobe Reader included in the Software CD-ROM.

Setting up the application software

- To use this camera with a PC, install the application software first.
After this has been done, the stored images in the camera can be moved to the PC and can be edited by an image editing program.
- You can visit the Samsung web-site through the internet.

<http://www.samsungcamera.com> : English
<http://www.samsungcamera.co.kr> : Korean

1. Install the Digimax Master by following the instructions shown on your PC monitor.

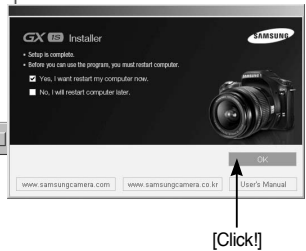
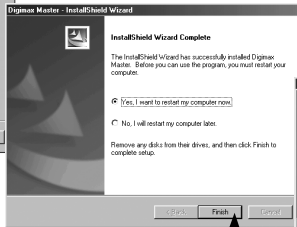
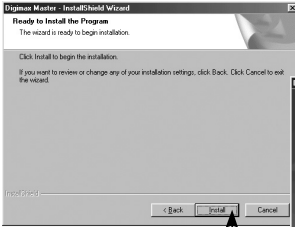
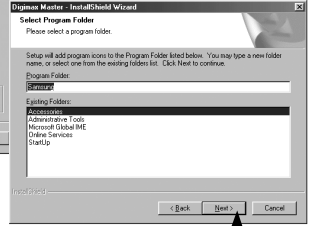
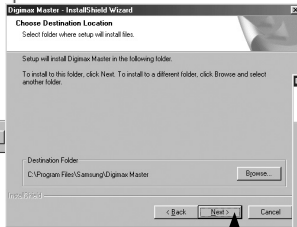
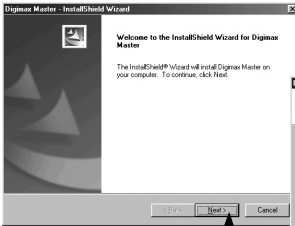

Setting up the application software

2. After restarting the computer, connect the PC to the camera with the USB cable.

3. Turn the camera power on.

The [Found New Hardware Wizard] will open and the computer will recognize the camera.

※ If your OS is Windows XP, an image viewer program will open.

If the download window of Digimax Master opens after starting Digimax Master, the camera driver was setup successfully.

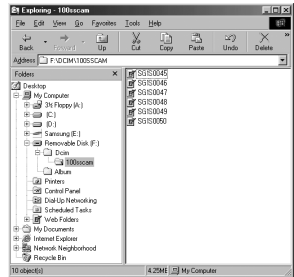

Starting PC mode

- In this mode, you can download stored images to your PC through the USB cable.
- The LCD monitor is always turned off in PC mode.

■ Connecting the camera to a PC

1. Press the MENU button and select the [X↓ Set-up] menu.
2. Set [Transfer Mode] on camera to [PC].
3. Connect the PC to the camera with the USB cable.

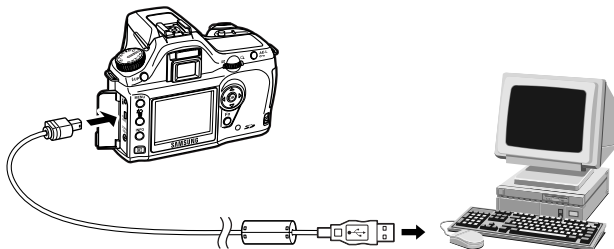
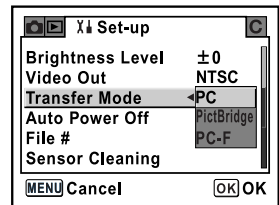

Removable Disk

■ Downloading stored images

You can download the still images stored on the camera to your PC's hard disk and print them or use a photo editing software to edit them.

1. Connect the camera to your PC with the USB cable.
2. On your computer's desktop display, select [My Computer] and double click [Removable Disk → DCIM → 100SSCAM].
The image files will then be displayed.

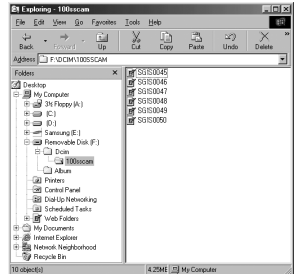

3. Select an image and press the right mouse button.

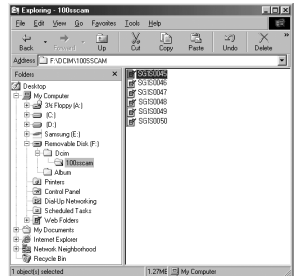

4. A pop-up menu will open.
Click the [Cut] or [Copy] menu.
 - [Cut] : cuts a selected file.
 - [Copy] : copies files.

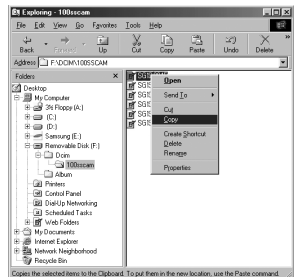

5. Click a folder where you want to paste the file.

Removable Disk

- Press the right mouse button and a pop-up menu will open.
Click [Paste].

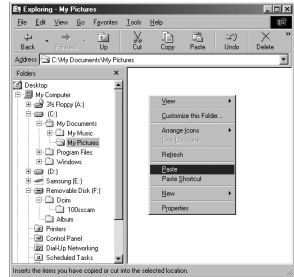

- An image file is transferred from the camera to your PC.

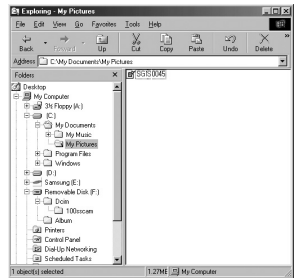

- By using [Digimax Master], you can see the images stored in the memory directly on the PC monitor and you can copy or move the image files.

CAUTION

- We recommend that you should copy the images to the PC to view them. Opening images directly from the removable disk may be subject to unexpected disconnection.
- When you upload a file that is not taken by this camera to the Removable Disk, the [Camera cannot display this image] message will be displayed on the LCD monitor in the PLAY mode, and [?] message is displayed in THUMBNAIL mode.

Removing the removable disk

■ Windows 2000/ME/XP

(The illustrations may be different from the real display depending on the Windows O/S.)

1. Check whether the camera and PC is transferring a file. If the Card in use lamp blinks, you have to wait until the lamp is turned off.
2. Double-click the [Unplug or Eject Hardware] icon on the task bar.



3. The [Unplug or Eject Hardware] window will open. Select the [USB Mass Storage Device] and click the [Stop] button.

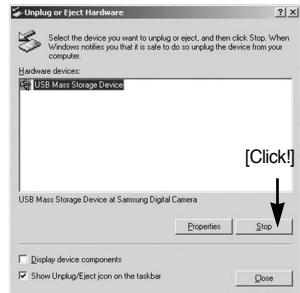

4. The [Stop a Hardware device] window will open. Select the [USB Mass Storage Device] and click the [OK] button.



5. A [Safe to Remove Hardware] window will open. Click the [OK] button.



Removing the removable disk

6. A [Unplug or Eject Hardware] window will open.
Click the [Close] button and the removable disk may then be removed safely.

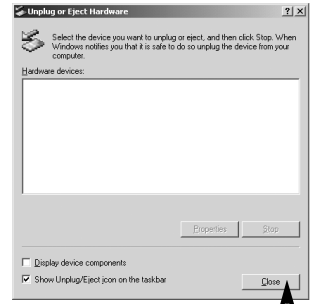

7. Unplug the USB cable.

[Click]

Setting up the USB Driver for MAC

1. A USB Driver for MAC is not included with the software CD as MAC OS supports the camera driver.
2. Check the MAC OS. This camera is compatible with MAC OS 9.0 or later.
3. Connect the camera to the Macintosh and turn the camera power on.
4. A new icon will be displayed on the desktop after connecting the camera to the MAC.

Using the USB Driver for MAC

1. Double click a new icon on the desktop and the folder in the memory will be displayed.
2. Select an image file and copy or move it to MAC.

CAUTION

- For Mac OS 10.0 or later : First complete uploading from computer to camera and then remove the removable disk with the Extract command.

Digimax Master

- You can download, view, edit and save your digital images and movies with this software. This software is only compatible with Windows except for the Windows 98.
- To start the program, click [Start → Programs → Samsung → Digimax Master → Digimax Master].

● Downloading images

1. Connect the camera to your PC.

2. A window for downloading images will display after connecting the camera and your PC.

- To download the captured images, select the [Select All] button.
- Select desired folder in the window and click the [Select All] button. You can save captured images and selected folder.
- If you click the [Cancel] button, downloading will be cancelled.

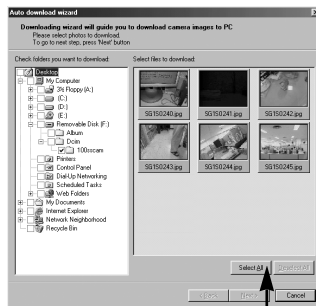

[Click!]

3. Click [Next >] button.

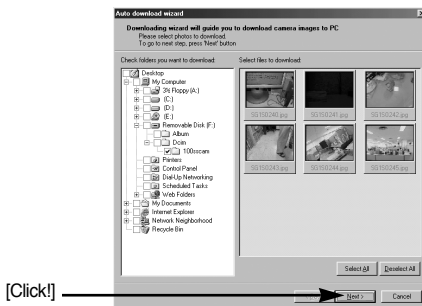

[Click!]

Digimax Master

4. Select a destination and make a new folder in which to save downloaded images and folders.
 - Folders will be made in order of date and images will be downloaded.
 - Folder names can be made as you want and images will be downloaded.
 - After selecting a folder that was made before, images will be downloaded.
5. Click [Next >] button.

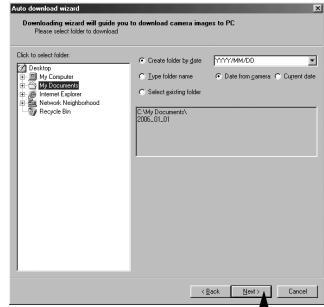

[Click!]

6. A window will open as shown alongside.
The destination of the selected folder will be displayed on the upper side of the window.
Click the [Start] button to download the images.

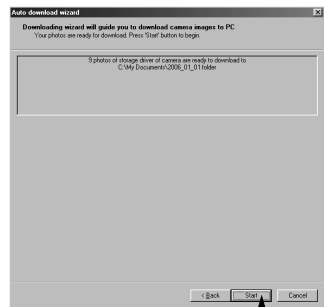

[Click!]

7. Downloaded images will be displayed.

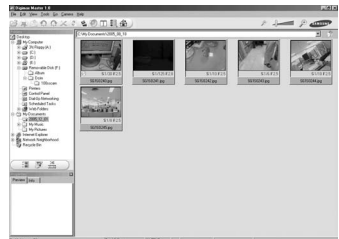

Digimax Master

- Image viewer : You can view the stored images.

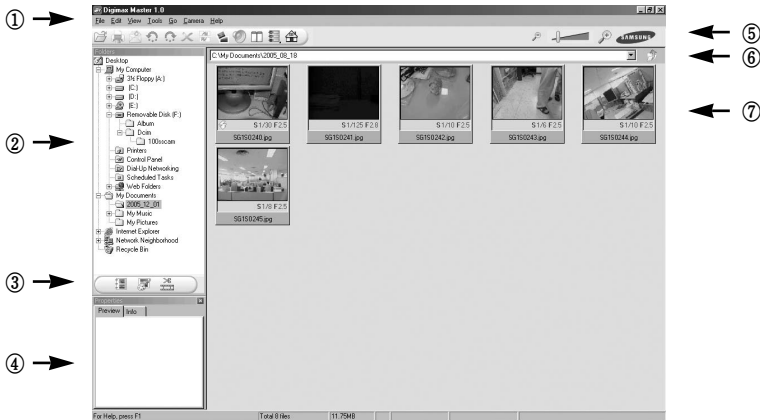

- Image viewer functions are listed below.

- ① Menu bar : You can select menus.

File, Edit, View, Tools, Change functions, Auto download, help, etc.

- ② Image selection window : You can select the desired images in this window.
- ③ Media type selection menu : You can select image viewer, image edit, movie edit functions in this menu.
- ④ Preview window : You can preview a image or a movie clip and check the multi media information.
- ⑤ Zoom bar : You can change preview size.
- ⑥ Folder display window : You can see the folder location of the selected image.
- ⑦ Image display window : Images of the selected folder are displayed.

※ Refer to the [Help] menu in Digimax Master for further information.

Digimax Master

- Image edit : You can edit the still image.



- Image edit functions are listed below.

- ① Edit menu : You can select the following menus.
 - [Tools] : You can resize or crop the selected image. See the [Help] menu.
 - [Adjust] : You can modify image quality. See the [Help] menu.
 - [Retouch] : You can change image or insert effects on the image. See the [Help] menu.
- ② Drawing tools : Tools for editing an image.
- ③ Image display window : a selected image displays in this window.
- ④ Preview window : You can preview the changed image.

- ※ A still image edited with Digimax Master can't be played back on the camera.
- ※ Refer to the [Help] menu in Digimax Master for further information.

Digimax Master

- DNG converter : You can convert a RAW (*.pef, *.dng) file into a JPEG or TIFF file format.



- DNG converter functions are listed below.

- ① Histogram display : Histogram of displayed image will be displayed.
- ② Tools : You can edit the RAW (*.pef, *.dng) files as you want
 - [White Balance] : You can edit the colour temperature and saturation of the image.
 - [Exposure] : You can edit the Exposure value, Contrast and gamma value.
 - [Sharpness] : You can edit the Sharpness of the image.
- ③ File format : You can convert the RAW (*.dng) file into a file format you prefer (*.jpg, *.tiff).

※ Refer to the [Help] menu in Digimax Master for further information.

Digimax Master

- **Movie edit** : You can have still images, movies, narration and music all in one movie file.



- Movie clip edit functions are listed below.

- ① **Edit menu** : You can select the following menus.

[Add Media] : You can add other media elements to a movie.

[Edit Clip] : You can change the brightness, contrast, colour and saturation.

[Effects] : You can insert an effect.

[Set Text] : You can insert texts.

[Narrate] : You can insert a narration.

[Produce] : You can save the edited multi media as a new file name.

You can select AVI, Windows media (wmv), Windows media (asf) and movie clip for this camera (avi, MPEG-4) file types.

- ② **Frame display window** : You can insert multi media in this window.

- ※ Some movie clips that were compressed with a codec that is not compatible with the Digimax Master can't play back in the Digimax Master.
- ※ Refer to the [Help] menu in Digimax Master for further information.

MEMO

A large, empty rectangular box with rounded corners, intended for writing a memo. The box is outlined in a thin gray line and occupies most of the page below the header.

7 Appendix

Explains troubleshooting, introduces optional accessories and provides various resources.

| | |
|----------------------------|-----|
| Default Settings | 186 |
| Cleaning the CCD | 190 |
| Optional Accessories | 192 |
| Error Messages | 194 |
| Troubleshooting | 196 |
| Main Specifications | 200 |
| Glossary | 202 |
| Index | 206 |

Default Settings

- The table below lists the factory default settings.

Table notations are as follows.

- Last Memory Setting

Yes : The current setting (last memory) is saved when the camera is turned off.









No : The setting returns to the default setting when the camera is turned off.

- Reset Setting

Yes : The setting returns to the default setting with the reset function (p.166).

No : The setting is saved even after reset.

- [ Rec. Mode] Menu

| Item | Default Setting | Last Memory Setting | Reset Setting | Page |
|------------------|---|---------------------|---------------|-------|
| Image Tone |  (Bright) | Yes | Yes | p.106 |
| Recorded Pixels |  (3008*2000) | Yes | Yes | p.107 |
| Quality Level |  (Best) | Yes | Yes | p.108 |
| Saturation |  (0) | Yes | Yes | p.109 |
| Sharpness |  (0) | Yes | Yes | p.109 |
| Contrast |  (0) | Yes | Yes | p.109 |
| Instant Review | 1 sec | Yes | Yes | p.165 |
| Auto Bracket | ±0.5/ 0 - + | Yes | Yes | p.144 |
| AE Metering |  (Multi-segment) | Yes | Yes | p.129 |
| Swch dst msr pt |  (Auto) | Yes | Yes | p.120 |
| AF Mode | AF.S (Single mode) | Yes | Yes | p.119 |
| Flash Exp. Comp. | 0.0 | Yes | Yes | p.145 |

- [ Playback] Menu

| Item | Default Setting | Last Memory Setting | Reset Setting | Page |
|-------------------|-----------------|---------------------|---------------|-------|
| Plybkb dsply mthd | Images only | Yes | Yes | p.155 |
| Bright Portion | OFF | Yes | Yes | p.155 |
| Digital Filter | B&W | Yes | Yes | p.69 |
| Slideshow | 3 sec | Yes | Yes | p.66 |

Default Settings

- [X] Set-up] Menu

| Item | | Default Setting | Last Memory Setting | Reset Setting | Page |
|------------------|--------------------|--|---------------------|---------------|-------|
| Format | | - | - | - | p.157 |
| Beep | | <input checked="" type="checkbox"/> (On) | Yes | Yes | p.158 |
| Date Adjust | | According to default setting | Yes | No | p.158 |
| World Time | World Time setting | <input type="checkbox"/> (Off) | Yes | Yes | p.159 |
| | Hometown (City) | According to default setting | Yes | No | |
| | Hometown (DST) | According to default setting | Yes | No | |
| | Destination (City) | Same as Hometown | Yes | No | |
| | Destination (DST) | Same as Hometown | Yes | No | |
| Language | | According to default setting | Yes | No | p.162 |
| Guide display | | <input checked="" type="checkbox"/> (On) | Yes | Yes | p.162 |
| Brightness Level | | 0 | Yes | Yes | p.163 |
| Video Out | | According to default setting | Yes | No | p.163 |
| Transfer Mode | | PC | Yes | Yes | p.82 |
| Auto Power Off | | 1 min | Yes | Yes | p.164 |
| File # | | SerialNo | Yes | Yes | p.164 |
| Sensor Cleaning | | - | - | - | p.190 |
| Reset | | - | - | - | p.166 |

Default Settings

● [C Custom Setting] Menu

| Item | Default Setting | Last Memory Setting | Reset Setting | Page |
|-----------------------------------|----------------------------------|---------------------|---------------|--------------|
| Setting | <input type="checkbox"/> (Off) | Yes | Yes | p.98 |
| Noise Reduction | On | Yes | Yes | p.139 |
| Expsr Setting Steps | 1/2 EV Steps | Yes | Yes | p.141 |
| ISO Corction in AUTO | ISO 200-800 | Yes | Yes | p.113 |
| ISO Snstvty Wrn Dspl | Off | Yes | Yes | p.114 |
| Link AF Point and AE | Off | Yes | Yes | p.130 |
| Meter Operating Time | 10 sec | Yes | Yes | p.131 |
| AE-L with AF locked | Off | Yes | Yes | p.123 |
| Recordable Image No. | Remaining image storage capacity | Yes | Yes | p.98 |
| OK btn when shooting | Off | Yes | Yes | p.118, p.120 |
| AE-L btnn on M expsr | Program Line | Yes | Yes | p.139 |
| Superimpose AF Area | On | Yes | Yes | p.120 |
| AF in remote control | Off | Yes | Yes | p.98 |
| Fl with S lens used ^{*1} | Not available | Yes | Yes | |
| Using aperture ring ^{*2} | Prohibited | Yes | Yes | |
| Release when Chrging | Off | Yes | Yes | p.146 |
| Instant Review Dsply | Normal Playback | Yes | Yes | p.165 |
| Mag to Strt Zm Plybk | 1.2 times | Yes | Yes | p.99 |
| Man. WB Measurement | Entire screen | Yes | Yes | p.111 |
| Color Space | sRGB | Yes | Yes | p.115 |
| Reset Custom Fcnctn ^{*3} | - | - | - | p.167 |

*1 : When the screw mount lens is in use, [Fl with S lens used] menu is available.

*2 : When a lens that has aperture ring is in use, [Using aperture ring] menu is available.

*3 : ResetReset settings in [C Custom Setting] menu.

Default Settings

- Fn Menu

| Item | Default Setting | Last Memory Setting | Reset Setting | Page |
|-----------------|--|---------------------|---------------|-------------------------|
| Drive Mode | <input type="checkbox"/> (Single frame shooting) | No*1 | Yes | p.51, p.53, p.57, p.142 |
| Flash Mode |  (Auto) | Yes | Yes | p.47 |
| White Balance | AWB (Auto) | Yes | Yes | p.110 |
| ISO Sensitivity | AUTO | Yes | Yes | p.113 |
| DPOF Settings | - | Yes | No | p.77 |
| Digital Filter | B&W | Yes | Yes | p.69 |
| Slideshow | 3 sec | Yes | Yes | p.66 |



*1 : Only continuous shooting settings are saved.

Cleaning the CCD

- Shadows may appear in the image for white backgrounds and other shooting conditions if the CCD becomes dirty or dusty. This indicates that the CCD must be cleaned. Please contact Samsung Camera service center for professional cleaning because the CCD is a precision part.

INFORMATION

- Do not use a spray type blower.
- Do not clean the CCD when the exposure mode is set to **B** (Bulb) mode.
- Always cap the lens mount area to prevent dirt and dust from accumulating on the CCD when no lens is on the camera.
- It is recommended to use the AC adapter (D-AC10, optional) when cleaning the CCD.
- When the battery level is low, a warning message [Not enough battery remaining to clean sensor] is displayed on the LCD monitor.
- If you are not using the AC adapter, please use batteries with ample capacity remaining. A warning beep will sound if the battery capacity becomes low during cleaning. Please stop cleaning immediately.
- Do not put the tip of the blower inside the lens mount area. If the power is turned off, this could cause damage to the shutter or the CCD sensor.
- The self-timer lamp blinks and [Cln] appears on the LCD panel while cleaning the CCD.

1. Turn the camera off and remove the lens.
2. Turn the camera on.
3. Select [Sensor Cleaning] on the [ Set-up] menu.
4. Press the four-way controller ().
 - The Sensor Cleaning screen appears.

Cleaning the CCD

5. Use the four-way controller (▲) to select [Mirror Up].

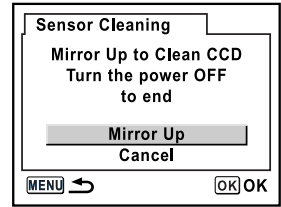

6. Press the **OK** button.

- The mirror is locked in the up position.

7. Clean the CCD.

- Use a brush-less blower to remove dirt and dust from the CCD. Using a blower with a brush may scratch the CCD. Do not wipe the CCD with a cloth.

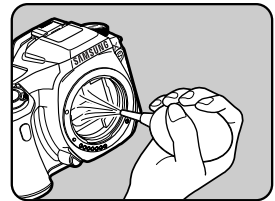

8. Turn the camera off.

9. Attach the lens after the mirror returns to its original position.

Optional Accessories

- Dedicated accessories are available for this camera. Please contact a service center for details regarding accessories. Accessories for PENTAX DSLR can be used with SAMSUNG DSLR.

Cable Switch SSR-D1

- This is a remote shutter release cord. The cord length is 0.5 m.

Flash Accessories

- Auto Flash SEF-36PZF
This is an auto flash unit with a maximum guide number of 36 (ISO 100/m). Its features include slave-sync flash, contrast-control-sync flash, AF spot beam, high-speed sync, wireless flash and front/rear curtain-sync.

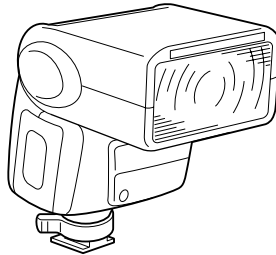

Optional Accessories

Camera Case

- Camera Case SCP-D1

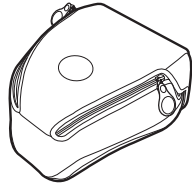

Others

- The accessories below are the same as the accessories that are packaged with the camera.

- Viewfinder cap



- Eyecup

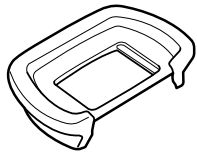

- Strap



Error Messages



| Error Message | Description |
|---|--|
| Memory card full | The SD Memory Card is full and no more images can be saved. Insert a new SD Memory Card or delete unwanted images. (p.27, 71) You may be able to save new images by changing the quality level or recorded pixels. (p.107, p.108) |
| No image | There are no images for playback on the SD Memory Card. |
| Camera cannot display this image | You are trying to play back an image in a format not supported by this camera. You may be able to play it back on another brand of camera or your computer. |
| No card in camera | The SD Memory Card is not inserted in the camera. (p.27) |
| Memory card error | The SD Memory Card has a problem, and image capture and playback are impossible. It may be viewable on a PC but not the camera. |
| Card not formatted | The SD Memory Card you have inserted is unformatted or has been formatted on a computer or other device and is not compatible with this camera. Use after formatting with the camera. |
| Card locked | A locked SD Memory Card is inserted in the camera. Unlock the SD Memory Card. (p.28) |
| Card is locked Rotation information cannot be saved | |
| This image is protected Rotation information cannot be saved | The selected rotated image is protected. Remove protection from the image. |
| Cannot use this card | The inserted card cannot be used on a camera. Insert a usable card. |
| Battery depleted | The batteries are exhausted. Install new batteries in the camera. (p.23) |
| Not enough battery remaining to clean sensor | Appears during CCD cleaning if battery set level is insufficient. Replace the battery set with a new one or use an AC adaptor (D-AC10, optional). (p.26) |

Error Messages



| Error Message | Description |
|-----------------------------------|---|
| Image folder could not be created | The maximum folder number (999) and file number (9999) are being used, and no more images can be saved. Insert a new SD Memory Card or format the card. (p.157) |
| The image is not stored | The image could not be saved because of an SD Memory Card error. |
| Settings not stored | The DPOF settings file could not be saved because SD Memory Card is full. Delete unwanted images and set DPOF again. (p.71) |
| RAW images cannot be set | DPOF cannot be applied to the RAW images. |
| RAW images are not supported | RAW images cannot be processed using the digital filter. |
| No image to be filtered | When digital filter is started from [ Playback] menu, this message appears if all saved images are RAW files or images captured with other cameras. |
| This image cannot be filtered | Appears when digital filter is started from Fn menu for images captured with other cameras. |
| No DPOF files | No file set with DPOF. Set DPOF and print. (p.77) |
| Printer error | There is an error with the printer and the file cannot be printed. Fix error and print. |
| No paper in a printer | Printer has run out of paper. Put paper in printer and print. |
| No ink in a printer | Printer has run out of ink. Replace ink and print. |
| Paper stuck in a printer | Paper is jammed in printer. Remove paper and print. |
| Data error | A data error has occurred during printing. |

Troubleshooting

We recommend checking the following items before contacting a service center.

| Problem | Cause | Remedy |
|------------------------------|---|---|
| Camera does not turn on | Batteries are not installed | Check if batteries are installed. If not, install batteries. |
| | Batteries are not installed properly | Check orientation of batteries. Re-insert batteries according to the ⊕⊖ symbols. (p.23) |
| | Battery power is low | Replace with a charged battery set or use the AC adapter (D-AC10, optional). (p.26) |
| The shutter does not release | Flash is charging | Wait until charging is finished. |
| | No available space on SD Memory Card | Insert SD Memory Card with available space or delete unwanted images. (p.27, 71) |
| | Recording | Wait until recording is finished. |
| The Autofocus does not work | Subject is difficult to focus on | Autofocus cannot focus well on subjects that have low contrast (the sky, white walls), dark colours, intricate designs, are moving quickly or scenery shot through a window or a net-like pattern. Lock focus on another object located at same distance (press shutter release button halfway), then aim at target and press shutter release button fully. Alternatively, use manual focus. (p.124) |
| | Subject is not in focusing area | Position subject in focus frame in middle of viewfinder. If the subject is outside the focusing area aim the camera at the subject and lock the focus (press shutter release button halfway), then compose picture and press the shutter release button fully. |
| | Subject is too close | Move away from the subject and take a picture. |
| | The focus mode is set to MF | Set the focus mode lever to AF . (p.116) |
| | The focus mode is set to AF.C (Continuous mode) | Set the focus mode to AF,S (Single mode). (p.119) |
| | The capture mode is set to  (Moving Object) mode | Set the capture mode to setting other than  (Moving Object) mode. (p.45) |

Troubleshooting

| Problem | Cause | Remedy |
|--|---|---|
| AE lock function does not operate | AE lock is not available when set to M (Manual) mode or B (Bulb) mode | Use AE lock with any setting other than M (Manual) mode or B (Bulb) mode. |
| Built-in Flash does not discharge | When flash mode is set to [Auto discharge] or [Auto flash+Redeye reduct], the flash will not discharge if the subject is bright | Set flash mode to [Manual discharge] or [Mani flash+Redeye reduct]. (p.47) |
| | Mode dial is set to  (Flash OFF) | Set mode dial to any setting other than  (Flash OFF). (p.45) |
| The power zoom system does not function | The camera does not have the power zoom function | Use manual zoom. (p.46) |
| USB connection with computer does not work properly* | The transfer mode is set to [PictBridge] | Set transfer mode to [PC]. |
| | An error occurred while sending USB data | Change the transfer mode to [PC-F]. |
| USB connection with printer does not work properly | The transfer mode is set to [PC] or [PC-F] | Set transfer mode to [PictBridge]. (p.82) |

* In rare cases, the camera may not operate correctly due to static electricity. This can be remedied by taking the batteries out and putting them back in again. When the mirror remains in the up position, take the batteries out and put them back in again. Then, turn the power on. The mirror will retract. After the procedure is done, if the camera operates correctly, it does not require any repairs.

* Refer to the software instructions for details on connecting the camera to a PC. (p.169)

Troubleshooting

- Please check the following if the USB connection malfunctions.

[Case 1] The USB cable is not connected or you are using a cable with an incorrect specification.
→ Use a USB cable with the correct specification.

[Case 2] The camera is not recognized by your PC. Sometimes, the camera may appear under [Unknown Devices] in Device Manager.
→ Turn off the camera, remove the USB cable, plug in the USB cable again, and then turn on the camera.

[Case 3] There is an unexpected error during file transfer
→ Turn the camera power off and on again. Transfer the file again.

[Case 4] When using the USB hub.
→ There may be a problem in connecting the camera to the PC through the USB hub if the PC and the hub are not compatible. Wherever possible, connect the camera to the PC directly.

[Case 5] Are other USB cables connected to the PC?
→ The camera may malfunction when it is connected to the PC at the same time as another USB cable. In this case, disconnect the other USB cable, and connect only one USB cable to the PC.

[Case 6] When I open the Device Manager (by clicking Start → (Settings) → Control Panel → (Performance and Maintenance) → System → (Hardware) → Device Manager), there are 「Unknown Devices」 or 「Other Devices」 entries with a yellow question mark (?) beside them or devices with an exclamation mark (!) beside them.
→ Right-click on the entry with the question (?) or exclamation (!) mark and select "Remove". Restart the PC and connect the camera the again. For Windows 98 PC, remove the camera driver also, restart the PC, and then reinstall the camera driver.

Troubleshooting

[Case 7]

In some security programs (Norton Anti Virus, V3, etc.), the computer may not recognise the camera as a removable disk.

→ Stop the security programs and connect the camera to the computer. Refer to the security program instructions about how to stop the program.

[Case 8]

If a PC connected with the camera stops responding while Windows is starting.

→ In this case, disconnect the PC and the camera and Windows will start.

If the problem happens continuously, set the Legacy USB Support to disable and restart the PC. The Legacy USB Support is in the BIOS setup menu (The BIOS setup menu differs from the PC manufacturers and some BIOS menus don't have Legacy USB Support). If you can't change the menu by yourself, contact the PC manufacturer or BIOS manufacturer.

[Case 9]

The camera is connected to the USB port located on the front of the computer.

→ When the camera is connected to the USB port located on the front of the computer, the computer may not recognise the camera.

Connect the camera to the USB port located on the back of the computer.

Main Specifications

| | | |
|------------------|---|--|
| Image Sensor | Type | 23.5mm x 15.7mm CCD |
| | Effective Pixel | Approx. 6.1 Mega-pixel |
| | Total Pixel | Approx. 6.3 Mega-pixel |
| Lens | Mount | PENTAX KAF bayonet mount |
| | Usable Lens | Schneider D-XENON Lens * All PENTAX DSLR lenses are available. * KAF2 (not power zoom compatible), KAF mount lenses, KA mount lenses |
| Viewfinder | Type | Pentaprism, Natural-Bright-Matte Focusing Screen |
| | Field of View | 95% |
| | Magnification | 0.95X (50mm 1.4/50mm · ∞) |
| | Dioptr Adjustment | -2.5m ⁻¹ ~ 1.5m ⁻¹ |
| Focusing | Type | TTL phase-matching 11 points wide AF |
| | Modes | AF Single (with focus lock), Manual focus, Continuous AF |
| Shutter | Type | Electronically controlled vertical-run focal plane shutter |
| | Speed | 30 ~ 1/4,000 sec. with Bulb |
| Exposure Control | Metering System | TTL open-aperture 16-segment (coupled with lens and AF information) Metering : Multi, Center-weighted, Spot |
| | Compensation | ±2 (1/3EV or 1/2EV steps) |
| | ISO Equivalent | Auto, 200, 400, 800, 1600, 3200 |
| Flash | Type | Built-in retractable P-TTL auto pop-up flash |
| | Modes | Auto, Manual, Auto/Red-eye reduction, Manual/Red-eye reduction |
| | Guide Number | 15.6 (at ISO 200) |
| | Angle of View Coverage | 28mm wide-angle (equivalent to 35mm) |
| | Sync. Speed | 1/180 sec. (with SEF-36PZF SAMSUNG dedicated flash) |
| | Recharging Time | Approx. 3 sec. |
| White Balance | External Flash | SEF-36PZF (optional) |
| | Auto, Daylight, Shade, Cloudy, Tungsten, Fluorescent (W, D, N), Flash, Manual | |
| Shooting | Modes | AUTO SCN, Normal, Portrait, Landscape, Macro, Moving Object, Night scene, Flash off, Program AE, Shutter Priority AE, Aperture Priority AE, Manual, Bulb |
| | Drive Modes | Single, Continuous, Auto Bracket |
| | Continuous | 2.8 fps up to 8 frames (JPEG), 5 frames (RAW) |
| Self-timer | 2 sec., 12 sec., Remote control, Remote control 3 sec | |

Main Specifications

| | | |
|-----------------------|---------------------|--|
| Storage | Media | SD Card (up to 1GB guaranteed) |
| | File Format | RAW (PEF), JPEG (DCF), EXIF 2.21, DPOF 1.1, PictBridge 1.0 |
| | Image Size | 6M : 3008x2008 pixels (RAW) 6M : 3008x2000, 4M : 2400x1600, 1.5M : 1536x1024 pixels (JPEG) |
| | Capacity (128MB) | 6M : RAW 10 Super Fine 33 Fine 68 Normal 114 4M : - Super Fine 50 Fine 94 Normal 158 1.5M : - Super Fine 103 Fine 169 Normal 266 ※ These figures are measured under Samsung' s standard conditions and may vary depending on shooting conditions and camera settings. |
| Image Play | Type | Single image, Thumbnails, Slide show |
| | Editing | Rotate, Digital Filter |
| | Digital Filter | B&W, Sepia, Soft, Slim |
| Interface | | Digital Output Connector : USB 2.0 (HI-SPEED) Video Output : NTSC, PAL (user selectable) DC Power Input Connector : DC 6.5V |
| Power Source | | 4xAA Alkaline, Lithium, Ni-MH, 2 x CR-V3 (Lithium) batteries |
| Dimensions (WxHxD) | | 125x92.5x67mm (excluding the projecting parts of the camera) |
| Weight | | 505g (without batteries and card) |
| Operating Temperature | | 0 ~ 40° C |
| Operating Humidity | | 5 ~ 85% |
| Software | Camera Driver | Storage Driver (Windows 2000/ME/XP, Mac OS 9.0 or later) |
| | Application | Digimax Master |

* Specifications are subject to change without prior notice.

* All trademarks are the property of their respective owners.

* Accessories for PENTAX DSLR can be used with SAMSUNG DSLR.

Glossary

AdobeRGB

Colour space recommended by Adobe Systems, Inc. for commercial printing. Wider range of colour reproduction than sRGB. Covers most of the colour range so colours only available when printed are not lost when editing images from a computer. When image is opened by non-compatible software, the colours look lighter.

AE Metering

Brightness of subject is measured to determine exposure. In this camera, select from [Multi-segment Metering], [Center-weighted Metering] and [Spot Metering].

Aperture

The aperture increases or reduces the light beam (the amount of light) that passes through the lens.

Auto Bracket

For automatically changing the shooting conditions. When the shutter button is pressed, three images are shot. The first one has no compensation, the second is under-exposed and the third is over-exposed.

Bright Portion

Over exposed area in the image loses contrast and appears white.

Camera Shake (Blur)

When the camera moves while the shutter is open, the entire image appears blurred. This occurs more often when shutter speed is low.

Prevent camera shake by raising the sensitivity, using the flash, or by using a faster shutter speed.

Alternatively, use a tripod to stabilize the camera. Because camera motion causes camera shake, use the self-timer, the remote control unit, and the cable switch to prevent.

CCD (Charge Coupled Devices)

Photography element which converts the light entering through the lens into electric signals.

Glossary

Colour space

A defined range of colours from the spectrum which are used. In digital cameras, [sRGB] is defined as the standard Colour Space by Exif. In this camera, [AdobeRGB] is also used because of its richer colour expression over sRGB.

Colour Temperature

This numerically expresses the colour of the light source illuminating the subject. This is indicated in absolute temperature, using Kelvin (K) units.

The colour of light shifts to a bluish colour as the colour temperature rises, and to a reddish colour as the colour temperature falls.

DCF (Design Rule for Camera File System)

A digital camera file system standard established by the Japan Electronics and Information Technology Industries Association (JEITA).

Depth of Field

Area of focus. This depends on the aperture, lens focal length, and distance to the subject. For example, select a smaller aperture to increase the depth of field or use a larger aperture to decrease the depth of field.

DPOF (Digital Print Order Format)

Rules for writing information onto a card with recorded images regarding the specific images and number of copies to be printed. Prints can easily be made by taking images to a DPOF photo printing store.

EV (Exposure Value)

Exposure Value is determined by the combination of the aperture value and the shutter speed.

EV Compensation

Process of adjusting the image brightness by changing the shutter speed and aperture value.

Exif (Exchangeable image file format for digital still camera)

A standard digital camera file format established by the Japan Electronics and Information Technology Industries Association (JEITA).

Focus point



Position in the viewfinder that determines focus.

Glossary

Histogram

A graph that shows the darkest and brightest points in an image. The horizontal axis represents the brightness and the vertical axis represents the number of pixels. This is useful when you wish to refer to the exposure status of an image.

JPEG

An image compression method. The image is recorded in JPEG format when the quality level is set to  (Best),  (Better), or  (Good). Images recorded in JPEG format are suited for viewing on your PC or for attaching to e-mail.

ND (Neutral Density) Filter

A filter which reduces the amount of light entering the camera lens by a measured amount, without affecting the picture itself.

Noise Reduction

Process to reduce noise (image roughness or unevenness) caused by slow shutter speed.

NTSC/PAL

These are video output formats. NTSC is mainly used in Japan, North America, and South Korea. PAL is mainly used in Europe and in China.

Quality Level

This refers to the image compression ratio. The lower the compression, the more detailed the image. The image becomes rougher as the compression rate rises.

RAW data

Unedited image data output from the CCD. RAW data is data before being internally processed by the camera. Settings like White balance, contrast, saturation and sharpness can be manipulated individually on each file. In addition, RAW data is 12-bit data that contains 16 times the information of 8-bit JPEG and TIFF data. Rich gradations are possible. Transfer RAW data to your computer and use the provided software to create image data with different settings, such as JPEG or TIFF.

Glossary

Recorded Pixels

Indicates the size of the image by the number of pixels. The more pixels that compose a picture, the larger the image size.

Sensitivity

The sensitivity of the camera to light; the equivalent of film speed in a camera using film. With a high sensitivity, images can be shot with a high shutter speed even in dimly lit places, reducing camera shake. However, images with high sensitivity are more susceptible to noise.

Shutter Speed

The length of time that the shutter is open and light strikes the CCD. The amount of light that strikes the CCD can be changed by altering the shutter speed.

sRGB (standard RGB)

International standard of colour space established by the IEC (International Electrotechnical Commission). This is defined from colour space for PC monitors and is also used as the standard colour space for Exif.

Vignetting



















Vignetting occurs when corners of pictures are darkened because the subject was blocked by the hood or filter or the flash was blocked.

White Balance

While shooting, colour temperature is adjusted to match the light source so that the subject appears to have correct colour.

Index

Symbols

| | |
|--|---------|
| [ Rec. Mode] Menu | 96, 186 |
| [ Playback] | 96, 186 |
| [ Set-up] Menu | 97, 187 |
| [ Custom Setting] MENU | 98, 188 |
|  Auto Scene | 41, 45 |
|  Normal | 45 |
|  Portrait | 45 |
|  Landscape | 45 |
|  Macro | 45 |
|  Moving Object | 45 |
|  Night Scene Portrait | 45 |
|  Flash OFF | 45 |
|  button | 91, 93 |
|  button | 93 |
|  UP button | 91 |
|  button | 93 |
|  Av button | 91 |
|  Preview | 128 |

A

| | |
|--|--------|
| AC Adapter | 26 |
| Adding the Date | 77 |
| AdobeRGB | 115 |
| AE lock | 141 |
| AE Metering | 129 |
| AE-L button | 91 |
| AF Mode | 119 |
| SEF-36PZF | 150 |
| AF.C (Continuous mode) | 119 |
| AF.S (Single mode) | 119 |
| Alkaline batteries | 24 |
| Aperture | 127 |
| Aperture Priority Mode Av | 135 |
| Auto Bracket | 142 |
| Auto Scene  | 41, 45 |
| Auto Power Off | 164 |
| AF (Autofocus) | 116 |

| | |
|--|-----|
| Autofocus AF | 116 |
| Automatic Sensitivity Correction | 113 |
| AV Equipment | 68 |
| Av (Aperture Priority) mode | 135 |

B

| | |
|-------------------------------------|---------|
| B&W (Digital Filter) | 69 |
| Batteries | 24 |
| Beep | 158 |
| Bright | 106 |
| Bright Portion | 155 |
| Brightness of the LCD Monitor | 163 |
| Built-in flash | 47, 145 |
| B (Bulb) Mode | 139 |
| Bulb Mode B | 139 |

C

| | |
|--|---------|
| Cable Switch | 139 |
| Capture Information | 15, 16 |
| Card access lamp | 13 |
| CCD Cleaning | 190 |
| Center-weighted | 129 |
| Cloudy (White Balance) | 110 |
| Colour space | 115 |
| Colour Temperature | 111 |
| Continuous Autofocus | 123 |
| Continuous mode AF.C | 119 |
| Continuous Shooting | 51 |
| Contrast | 109 |
| Contrast-Control-Sync Flash | 150 |
| Correct exposure | 126 |
| CR-V3 | 24 |
| Custom Function | 98 |
| [ Custom Setting] Menu | 98, 188 |



D

| | |
|-------------------|----|
| Date Adjust | 33 |
|-------------------|----|

Index

- Date change158
- Daylight (White Balance)110
- Daylight-Sync Shooting50
- Default Setting 31, 186
- Delete71
- Delete All Images72
-  (Delete) button93
- Deleting a Single Image71
- Depth of Field128
- Digital Filter69
- Diopter Adjust37
- Direct Printing81
- Display Language162
- Display Style158
- DPOF AUTOPRINT88
- DPOF Settings77
- Drive Mode100

- E**
- e-dial93
- Error Message194
- EV Compensation140
-  **Av** (EV Compensation/Av) button91
- Exposure126
- Exposure metering timer143
- Exposure Mode131
- Exposure Warning134, 136, 138
- External flash150

- F**
- File #164
- Filter69
- Fireworks139
- Fix Exposure123
- Fix Focus122
- Flash145
- Flash (White Balance)110
- Flash Compensation145
- Flash Off45
- Flash OFF 45
-  **UP** (Flash pop-up) button91
- Fluorescent Light (White Balance)110
- Fn** button91, 93
- Fn Menu100
- Focus Indicator99, 124
- Focus Lock122
- Focus mode lever91
- Focus point120
- Focusing116
- Format157
- Four-way controller91, 93









- G**
- Guide display14, 162

- H**
- High-Speed Flash Sync Mode152
- Histogram17, 165

- I**
- Image Tone106
- INFO** button91, 93
- Instant Review165
- ISO Sensitivity113
- ISO Sensitivity Warning Display114

- L**
- Landscape 45
- Language31
- Last Memory186
- LCD Monitor14
- LCD panel20
- Lens35
- Lens unlock button36, 90
- Lithium batteries24

Index

- M**
- Macro  45
 - Main switch 90, 92
 - MF (Manual focus) 124
 - Manual focus MF 124
 - Manual White Balance 111
 - Matte Field 125
 - MENU** button 91, 92
 - Menu Operation 94
 - Meter Operating Time 131
 - Mirror Lock Up 60, 91
 - Mode dial 91, 102
 - Moving Object  45
 - Multi-segment 129
- N**
- Natural 106
 - Night Scene 139
 - Night Scene Portrait 45
 - Ni-MH 24
 - Ni-MH rechargeable batteries 24
 - Nine-Image Display 64
 - Noise Reduction 139
 - Normal  45
 - NTSC 163
- O**
- OK** button 91, 93
 - Optional Accessories 192
- P**
- P** (Program) Mode 132
 - PAL 163
 - PC-F 197
 - PictBridge 81
 - Pixels 107
 - Playback 16, 61
 -  (Playback) button 91, 93
 - [ Playback] Menu 96, 186
 - Playback Time 25
 - Portrait  45
 - Power 30
 - Press fully 43
 - Press halfway 43
 - Preview 128
 - Print All 86
 - Print One 84
 - Print Service 77
 - Printer connection 83
 - Program Mode **P** 132
 - Protect 75
 -  (Protect) button 93
 - P-TTL (Auto) 151
 - P-TTL (Flash) 153
- Q**
- Quality Level 29, 108
- R**
- RAW 108
 - Rear Curtain Sync Flash 154
 - [ Rec. Mode] Menu 96, 186
 - Recorded Pixels 29, 107
 - Red-eye reduction 50, 154
 - Remaining image storage capacity 29
 - Remote Control 57
 - Reset 186
 - Rotate 62
 - SEF-36PZF 150
- S**
- Saturation 109
 - SD Memory Card 27
 - Select&Delete 73

Index

| | |
|---------------------------------------|------------|
| Selecting the Focusing Area | 120 |
| Self-Timer | 53 |
| Sensitivity | 113 |
| Sepia (Digital Filter) | 69 |
| [X↓ Set-up] Menu | 97, 187 |
| Shade (White Balance) | 110 |
| Sharpness | 109 |
| Shutter Priority Mode Tv | 133 |
| Shutter release button | 43, 90, 92 |
| Shutter speed | 126 |
| Single mode A.F.S | 119 |
| Slideshow | 66, 156 |
| Slim (Digital Filter) | 69 |
| Soft (Digital Filter) | 69 |
| Spot Metering | 130 |
| sRGB | 115 |
| Strap | 22 |

T

| | |
|---|-----|
| Transfer Mode | 82 |
| Tungsten Light (White Balance) | 110 |
| TV | 68 |
| Tv (Shutter Priority) mode | 133 |

U

| | |
|---------------------------|-----|
| USB cable | 81 |
| Using aperture ring | 188 |

V

| | |
|---------------------------|--------|
| Video cable | 68 |
| Video Output Format | 163 |
| Viewfinder | 18, 37 |
| Vignetting | 205 |

W

| | |
|---------------------|-----|
| White Balance | 110 |
| World Time | 159 |

Z

| | |
|--------------------|----|
| Zoom Display | 63 |
| Zoom Lens | 46 |

Correct Disposal of This Product



Correct Disposal of This Product (Waste Electrical & Electronic Equipment)

(Applicable in the European Union and other European countries with separate collection systems) This marking shown on the product or its literature, indicates that it should not be disposed with other household wastes at the end of its working life.

To prevent possible harm to the environment or human health from uncontrolled waste disposal, please separate this from other types of wastes and recycle it responsibly to promote the sustainable reuse of material resources. Household users should contact either the retailer where they purchased this product, or their local government office, for details of where and how they can take this item for environmentally safe recycling. Business users should contact their supplier and check the terms and conditions of the purchase contract.

This product should not be mixed with other commercial wastes for disposal.

An FCC warning

- This device has been tested in accordance with the limits of a class B digital device under item 15 of the FCC rules. These limits are designed to provide protection against harmful interference in commercial installation. This equipment generates, absorbs and can emit radio frequency energy. If it is not installed and used in accordance with the instructions, it may cause harmful interference to radio communication.

There is however, no guarantee that interference will not occur in some situations. Should any interference occur when this device is in operation, please try one or more of the following measures.

- Change the location and direction of any aerial.
 - Increase distance between the camera and the affected device.
 - Use a different socket away from the affected device.
 - Please contact a Samsung agent or a radio/TV engineer.
- This device complies with part 15 of the FCC Rules.
 - Changes or modifications not expressly approved by the party responsible for compliance could void user's authority to operate the equipment.

MEMO

A large, empty rectangular box with rounded corners, intended for writing a memo. The box is outlined in a thin grey line and occupies most of the page below the header.

MEMO

A large, empty rectangular box with rounded corners, intended for writing a memo. The box is white and occupies most of the page below the header.

SAMSUNG

SAMSUNG TECHWIN CO., LTD.
OPTICS & DIGITAL IMAGING DIVISION
145-3, SANGDAEWON 1-DONG, JUNGWONGU,
SUNGNAM-CITY, KYUNGKI-DO, KOREA
462-121
TEL : (82) 31-740-8086, 8088, 8090, 8092, 8099
FAX : (82) 31-740-8398
www.samsungcamera.com

SAMSUNG OPTO-ELECTRONICS AMERICA, INC.
HEADQUARTERS
40 SEAVIEW DRIVE, SECAUCUS, NJ07094, U.S.A.
TEL : (1) 201-902-0347
FAX : (1) 201-902-9342
WESTERN REGIONAL OFFICE
18600 BROADWICK ST.,
RANCHO DOMINGUEZ, CA 90220, U.S.A.
TEL : (1) 310-900-5263/5264
FAX : (1) 310-537-1566
www.samsungcamerausa.com

SAMSUNG FRANCE S.A.S.
BP 51 TOUR MAINE MONTPARNASSE 33,
AV .DU MAINE 75755, PARIS CEDEX 15, FRANCE
HOTLINE PHOTO NUMÉRIQUE :
00 800 22 26 37 27 (Numéro Vert-Appel Gratuit)
TEL : (33) 1-4279-2200
FAX : (33) 1-4320-4510
www.samsungphoto.fr

SAMSUNG OPTO-ELECTRONICS GMBH
AM KRONBERGER HANG 6
D-65824 SCHWALBACH/TS., GERMANY
TEL : 49 (0) 6196 66 53 03
FAX : 49 (0) 6196 66 53 66
www.samsungcamera.de

TIANJIN SAMSUNG OPTO-ELECTRONICS CO.,LTD.
7 PINGCHANG ROAD NANKAI DIST., TIANJIN
P.R CHINA POST CODE:300190
TEL : (86) 22-2761-4599
FAX : (86) 22-2769-7558
www.samsungcamera.com.cn

SAMSUNG OPTO-ELECTRONICS UK LIMITED
SAMSUNG HOUSE 1000 HILLSWOOD DRIVE
HILLSWOOD BUSINESS PARK
CHERTSEY KT16 OPS U.K.
TEL : 00800 12263727
(free for calls from UK only)
UK Service Hotline : 01932455320
www.samsungcamera.co.uk

RUSSIA INFORMATION CENTER SAMSUNG ELECTRONICS
117545 ST. DOROZHNAJA BUILDING 3,
KORPUS 6, ENTRANCE 2, MOSCOW, RUSSIA
TEL : (7) 095-363-1700
CALL FREE : (8) 800 200 0 400 (from Russia only)
www.samsungcamera.ru

* Internet address - <http://www.samsungcamera.com/>



The CE Mark is a Directive conformity mark of the European Community (EC)

6806-3253