



Rolleiflex Hy6

User's manual



Note:

Your camera carries this symbol which means that electrical and electronic appliances should not be disposed of with your household waste, but through separate take-back channels.

Disposal information for commercial users

1. In the European Union

If you have used this product for commercial purposes and wish to dispose of it:

Please contact your dealer who will provide relevant information. You may have to bear the cost of take-back and recycling. Small products (and small quantities) may be accepted by your local collecting point.

Spain: Please contact your collecting system or municipal authorities for recycling information.

2. Outside the European Union

Please inquire with your municipal authorities for proper disposal procedures.

Disposal information for private users

1. In the European Union

Caution: Do not dispose of this product together with your normal household waste!

A new EU Directive governing the return, treatment and recycling of electrical and electronic appliances requires used appliances to be disposed of separately.

After implementation of this Directive in the EU member states, private users may now return used electrical and electronic appliances free of charge to special collecting points. In some countries*, used appliances may also be returned free of charge to your dealer if you buy a comparable new product.

* For further details, contact your municipal authorities.

If your used electrical or electronic appliances contain dry cells or rechargeable batteries, these should be removed and disposed of separately according to local regulations.

Proper disposal of used appliances ensures controlled recycling and avoids damage to our environment.

2. In countries outside the European Union

Please contact your municipal authorities for information on proper disposal.

Switzerland: Used electrical and electronic appliances may be returned to your dealer free of charge even if you do not buy a new product.

Alternative collecting systems will be found on the homepages of www.swico.ch and www.sens.ch

Disposal information	»	2
Controls and parts overview	»	6
Introduction	»	10
Handling and use of the camera		
Battery charger/recharging the battery	»	12
Battery condition	»	13
Opening the battery compartment/ Inserting the battery	»	14
Attaching the lens	»	14
Opening the focusing hood	»	15
Closing the focusing hood	»	15
Attaching the carrying strap	»	15
Changing the handgrip position	»	16
Adjusting the wrist strap	»	16
Loading the film magazine and film advance		
Attaching the magazine/digital back	»	17
Opening the magazine	»	18
Removing the film insert	»	18
Loading the film insert	»	19
Positioning the film insert	»	20
Closing the magazine	»	20
Film advance	»	20
LC display	»	21
Switching on the LC display	»	21
Basic display	»	21
Default settings	»	21
Error detection	»	22
MODE button	»	22
Selecting the display mode	»	23
Entering the film speed	»	23
Selecting the film type	»	23
Multiple exposures	»	24
Focusing screens and viewfinder mask	»	24
Inserting the viewfinder mask	»	25
Changing format or magazine	»	25

CONTENTS

Removing the film	» 25	Shutter release	
Changing batteries	» 26	Tripping the shutter	» 46
Magazine malfunctions	» 27	Using a cable release	» 46
Changing the lens	» 28	Mirror lockup	» 47
Changing the viewfinder	» 28	Flash photography	
Changing magnifiers for eyeglass wearers	» 29	Flash photography	» 47
Changing focusing screens	» 29	Setting the type of flash synchronisation	» 48
Switching ON and OFF	» 30	Manual flash without SCA adapter	» 50
Single frame shooting	» 30	Using a dedicated SCA-3562 adapter	» 50
Continuous shooting	» 30	Automatic flash photography with SCA adapter in poor light	» 51
Shooting modes/Custom functions		– Programmed AE flash	» 52
View-finder information	» 31	– Aperture AE flash	» 52
Handgrip display	» 32	– Shutter-priority AE flash	» 52
Basic settings on handgrip display	» 33	– Fill-in autoflash with SCA adapter	» 53
Focusing	» 38	Manual flash exposure control	» 54
Autofocus mode		Custom functions	
– Single Focus	» 39	Shooting modes	» 54
– Continuous Focus	» 39	Bracketing	» 55
– Manual Focus (Focus indicator)	» 40	Self-timer	» 56
Exposure and shooting modes		Focus bracketing	» 56
Exposure metering	» 41	Ultra fast	» 57
– Multizone average	» 41	Exposure modes	» 58
– Centre-weighted multizone metering	» 41	Metering patterns	» 61
– Spot metering	» 42	Focusing	» 62
– Programmed AE	» 43		
– Shutter speed priority AE	» 43		
– Aperture priority AE	» 44		
– Metered manual AE	» 44		
Exposure compensation	» 45		
Depth-of-field preview	» 45		
Compensation of extraneous light	» 45		

Practical tips

Shooting at low temperature	» 64
Shooting in difficult situations	» 64
– Spot metering	» 64
– Substitute reading	» 65
– Close-up reading	» 65
– Lighting contrast	» 65
Macro photography	» 66
Caring for your camera	» 68
Various accessories	» 69
Interchangeable lenses	» 69
Tele-converters	» 70
Interchangeable magazines	» 70
Interchangeable view-finders	» 70
Focusing screens	» 72
Matte box	» 73
The Rolleiflex Hy6-System	» 74
Troubleshooting	» 78
Lens Table	» 82
Specifications	» 84

CONTROLS AND PARTS OVERVIEW

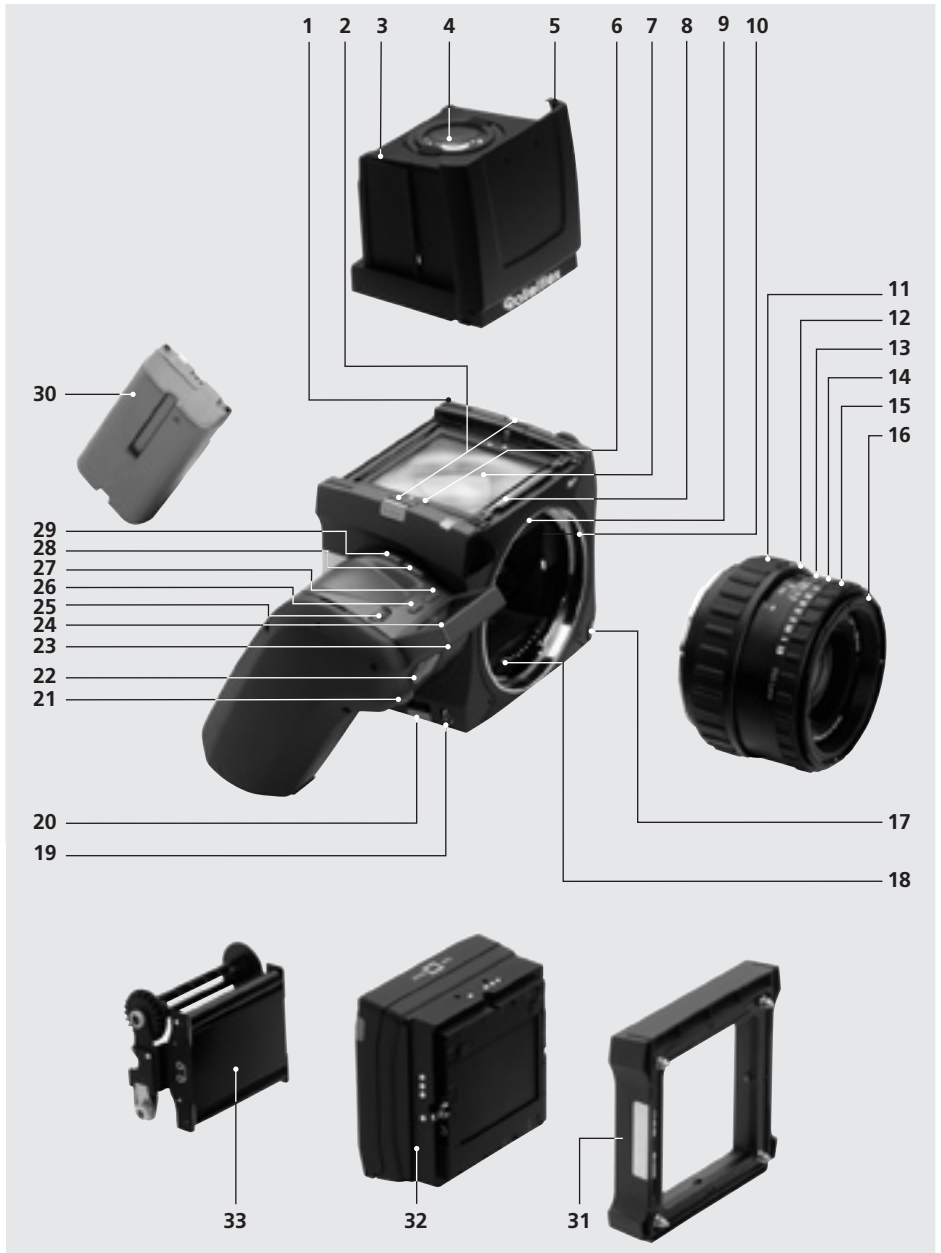

CONTROLS AND PARTS OVERVIEW

- 1 Strap holders, right and left
- 2 View-finder release, right and left
- 3 Magnifier holder
- 4 Viewfinder magnifier
- 5 Collapsible focusing-hood cover
- 6 Hinged frame, right and left
- 7 Interchangeable focusing screen
- 8 View-finder display
- 9 Red lens-bayonet index
- 10 Camera bayonet
- 11 Focusing ring
- 12 Focusing scale
- 13 Distance index and depth-of-field scale
- 14 Aperture scale (except on AFD lenses)
- 15 Shutter-priority and manual-aperture ring (except on AFD lenses)
- 16 Double filter bayonet
- 17 Lens-mount release button (also suitable for a camera-reset)
- 18 Contact strip for signal transfer (Camera)
- 19 X-syncro PC terminal
- 20 Grip release adjuster button
- 21 Aperture and menu scroll dial
- 22 Shutter release button
- 23 Mini-USB socket for e. g. Firmware Updates
- 24 Grip display
- 25 Shutter-speed and menu scroll dial
- 26 Button for basic camera settings
- 27 Button for special functions (life-picture with digital backs)
- 28 Mirror-up button
- 29 Stop-down button
- 30 Rechargeable battery
- 31 Magazine frame
- 32 Interchangeable magazine 4560
- 33 Film insert with pressure plate

CONTROLS AND PARTS OVERVIEW

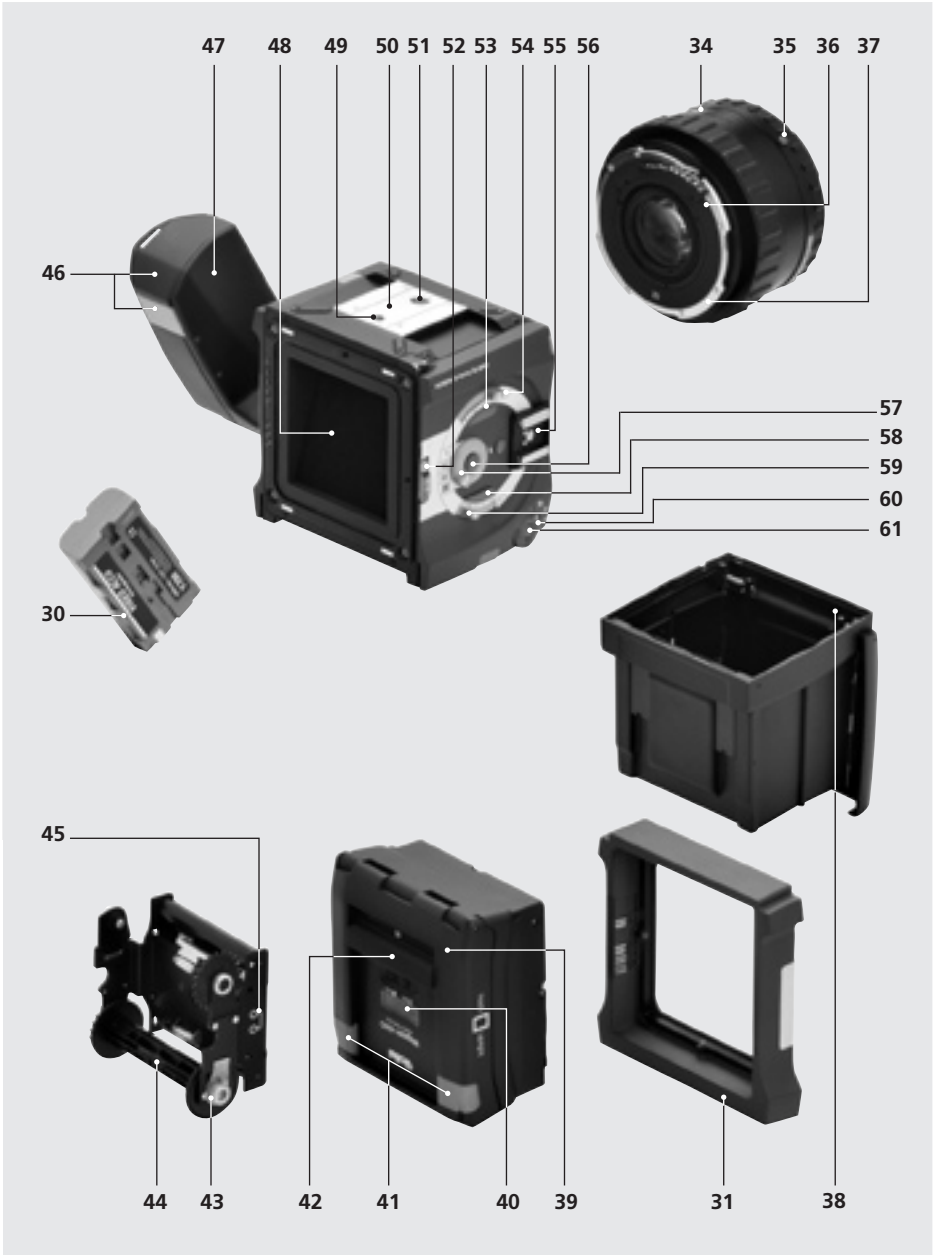

CONTROLS AND PARTS OVERVIEW

- 34 Interchangeable lens
- 35 Aperture-ring release (except on AFD lenses)
- 36 Lens bayonet with contact strip
- 37 Red mounting index
- 38 Detachable view-finder hood
- 39 Magazine back
- 40 Film-data display
- 41 Film-changing release buttons, left and right
- 42 Grip ridge for laminar drawslide
- 43 Film-spool spring clip
- 44 Empty film spool
- 45 Film-advance symbol
- 46 Battery compartment with release
- 47 Lateral handgrip
- 48 Auxiliary shutter
- 49 1/4" tripod socket *
- 50 Quick-release adapter for Novoflex Q-BASE tripod plates
- 51 3/8" tripod socket *
- 52 Magazine-frame release button
- 53 Focusing-mode menu button
- 54 Focusing-mode selector
- 55 Hot shoe for flash unit or accessories, with X contact and additional flash contacts
- 56 Menu button for ISO and EV values
- 57 Metering-pattern selector switch
- 58 Exposure-mode menu button
- 59 Exposure-mode selector switch
- 60 Master on/off switch
- 61 Shooting-mode menu button



*** Don't use long tripod screws!
Otherwise the camera will be damaged.**

Rolleiflex Hy6

Congratulations on your new Rolleiflex Hy6. We trust it will be your reliable and enjoyable companion for many years to come.

Your Rolleiflex Hy6 has been conceived as a highly professional camera. It is ideally suited for creative fashion, people and action photography, as well as for architectural and industrial applications.

WARNING

Your camera contains magnetic drive systems!

Do not place magnetic storage media, such as credit or memory cards near the camera!

X Note

The basic version of the camera is supplied in special packing to insure its safety from damage. It is advisable to keep this packing for future shipping. Also, it is good policy to make a note of the serial numbers of camera and lenses to facilitate replacement and proof of ownership in the case of loss.

Introduction

The following is a detailed description and illustration of the camera, in the practical order of all necessary manipulations, from assembly of the camera's main components right up to removal of the exposed film.

Next, you will find a number of practical tips with additional information to facilitate understanding the camera, followed by notes on the most important accessories.

The most important data on our line of interchangeable lenses is presented in tabular form.

A troubleshooting guide will help you detect and remedy possible operating errors.

Parts numbers in the text and in illustrations always refer to the same part as shown in the two picture plates.

X Notes

Like any precision instrument, your Rolleiflex Hy6 should be handled and maintained with care.

Special care must be used above all when attaching and removing interchangeable magazines, digital backs and lenses:

- » With the lens removed, NEVER touch the reflex mirror and its special light-absorbing surface!
Without a lens in place, the interior of the camera body should be protected by attaching its front cap.
- » With the magazine or digital back removed, be sure not to exert any pressure on the exposed auxiliary shutter. Without a magazine or digital back attached, the camera should be protected by its rear cap.
NEVER touch the sensor of a digital back with your fingers!
- » Always store separate magazines and digital backs with their protective cover in place.

Note for owners of earlier models of the Rolleiflex 6000 Series:

Compatibility of earlier lenses and accessories (SLX, 6002 and 6006 lenses)

Lenses for Rolleiflex SLX, 6002 and 6006 cameras (non-PQ/PQS lenses) are not compatible with your Rolleiflex Hy6.

PQ and PQS lenses for Rolleiflex 6008 cameras can be used with manual focusing.

The following accessories are not compatible with your Rolleiflex Hy6: FM1, ME1, Timer, MasterControl and SRC/MRC-120. The same applies to finder hoods of the 6000 Series.

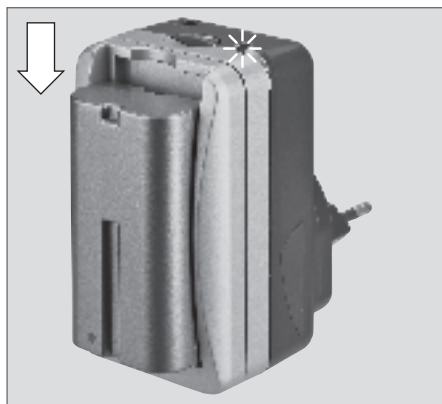

Battery charger/Recharging the battery

The Hähnel Ultima Charger serves to recharge the high-performance lithium-ion battery supplied with the camera. It is designed for line voltages from 100 – 240 VAC. Two adapter plugs are provided for use in Europe and the USA.

Before using the charger, fit the corresponding adapter plug (shown above, right). The charger is then ready for use, and the battery may be inserted in the charging compartment as shown. After inserting the battery, the charger's LED will light red, showing that charging is in progress. When the battery has reached 90% of its capacity, the LED will blink green. When the battery is fully charged, the LED will continuously light green, and the battery may be removed. Depending on the condition of the battery, charging may take 1 – 2 hours.



X Possible malfunctions

The battery should not be charged any further if the LED lights orange.

If the LED blinks red, the charging temperature is too high, and the charger will automatically switch off to prevent damage to battery and charger.

Charging from an automobile battery

The charger has a 12V socket (12 VDC) and may be used for charging from an automobile battery via a commercially available adapter cable for cigarette lighters.

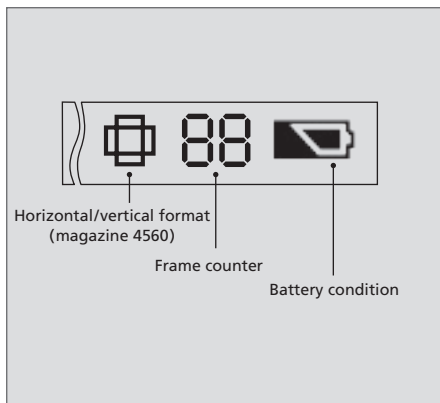

Safety hints

- » The charger should be used exclusively with the specified batteries.
- » Avoid humidity and moisture.
- » Keep the charger out of the reach of children.
- » Disconnect the charger from the power source after charging.
- » Do not use unnecessary force when inserting the contact plate and attaching or removing the battery.
- » Always keep contacts clean.
- » Do not bend contacts.
- » Avoid short-circuiting the contacts.
- » Do not store your battery in the charger.
- » Never expose battery or charger to heat or an open flame.
- » Do not dismantle or modify the charger.





Do not dispose of battery or charger with your household waste.

Battery condition

The battery condition is checked automatically as soon as the camera is switched on.

The display shows:

- » Symbol  for full or sufficient capacity.
- » Symbol  for partial discharge.

When the capacity of the battery is no longer sufficient, the camera will shut down. It is highly recommended always to carry a fully charged spare battery.

It is advisable to recharge the battery as soon as the symbol  appears, above all when shooting in cold weather.

The power supply of a fully recharged battery is sufficient for approx. 500 exposures at 20° C ambient temperature.

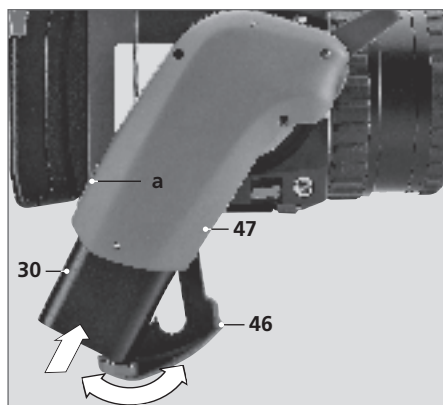

Opening the battery compartment and inserting the battery

Open battery-compartment cover **46** by pressing the release button **a** and slide the recharged battery **30** into handgrip **47** of the camera as shown. Then close the battery-compartment cover until it clicks into place.

Changing the battery

Unlock battery-compartment cover and withdraw discharged battery **30**. Insert charged battery into the compartment as described before and lock cover.

X Note

Be sure to change batteries only with the camera switched off so that any exposure settings that may be stored in the camera will not be lost.

To avoid premature discharge of the battery, return master switch **60** to OFF after use of the camera.

It is normal for rechargeable batteries to slowly discharge even when they are not used. To make sure that your battery will always be ready to use, it should be regularly be recharged at intervals of about 2 – 3 months.

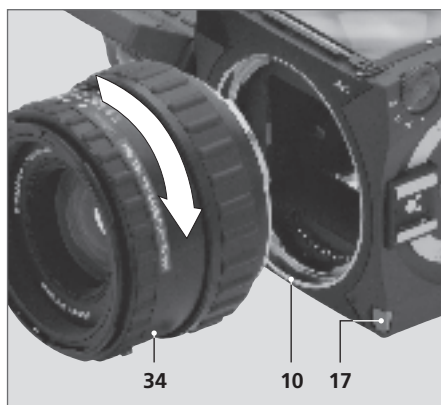

Attaching the lens

Remove front and rear lens caps. Press release **17** and remove body cap, turning it counter-clockwise. Align red dot of lens **34** with red index of camera bayonet **10**, insert it all the way and lock by clockwise rotation.

X Note

When using a teleconverter, extension tube or bellows attachment, be sure to attach these to the lens first, before attaching the assembly to the camera.

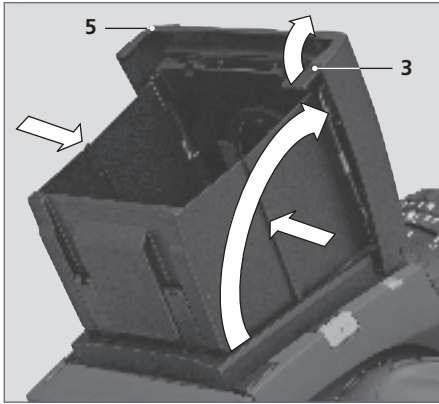

Opening the focusing hood

Lift focusing-hood cover **5** at the rear and swing up. To swing out the magnifier flap **3**, press the tab towards the front edge of the cover. The magnifier will swing up into position.

Closing the focusing hood

Swing magnifier flap **3** down. Press the two side panels inwards and let go. The hood will then close automatically.

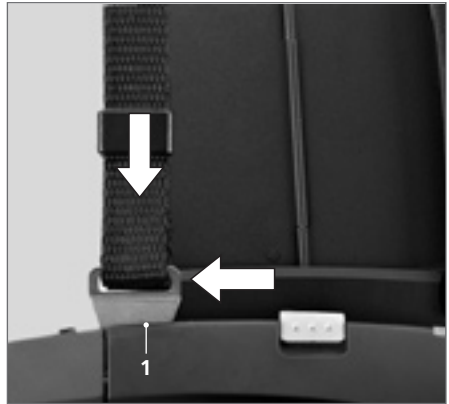

Attaching the carrying strap

Plug self-locking lugs straight into right-/left-hand slots **1** until they lock. To remove, lightly press on lugs, push them straight back and unhook them upwards.

The camera's strap holders leave the strap a wide margin of rotation and thus ensure comfortable carrying in all situations.

HANDGRIP / WRIST STRAP

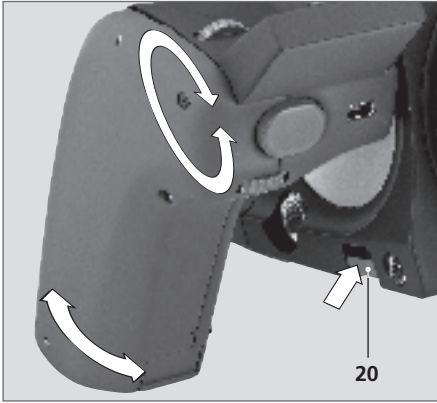

Changing the handgrip position

The handgrip has four click stops and thus guarantees comfortable operation with the folding finderhood (at waistlevel), the 45° prism finder and the 90° High-Eyepoint Finder (at eyelevel).

To change the grip position, press release **20** on the camera upwards until the grip can be freely moved. Then let go of the release and shift the grip forwards or backwards until it clicks into position.

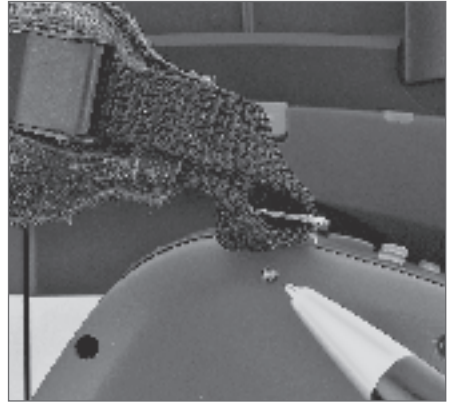

Adjusting the wrist strap

Loosen the loop belts at the buckle and adjust the wrist strap so that you can hold the camera safely with your right hand alone.

To remove the wrist strap, depress the two locking pins of the loop holder with a pointed object, such as a ball pen, and pull the holders from the guide slots. To attach the wrist strap, proceed in the reverse order.

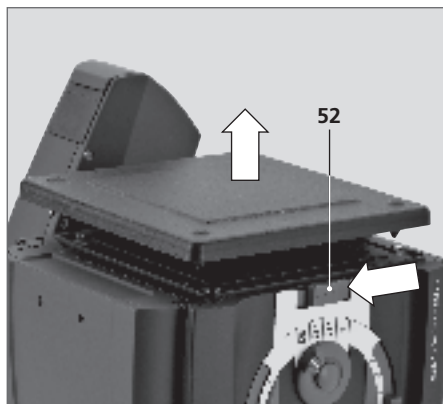

Attaching the magazine

Release rear body cap by pulling it straight up, and press release **52**. Then insert magazine frame **31** into the four openings until it clicks into position.

Insert the magazine straight into the magazine frame until it clicks into position. The symbol of the desired format (vertical/horizontal) should be visible from above.

Attaching a digital back

Attaching a digital back is similar to that of a film magazine. Note, that digital backs by Sinar or Leaf already come with an adapter frame so that mounting an adapter frame **31** is unnecessary.

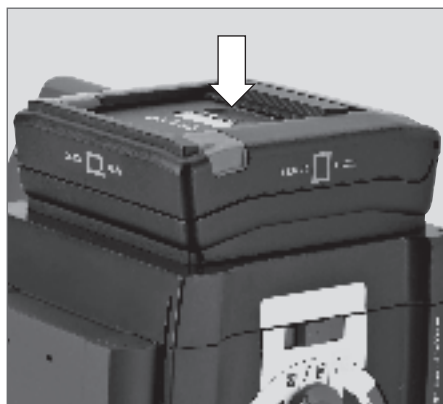
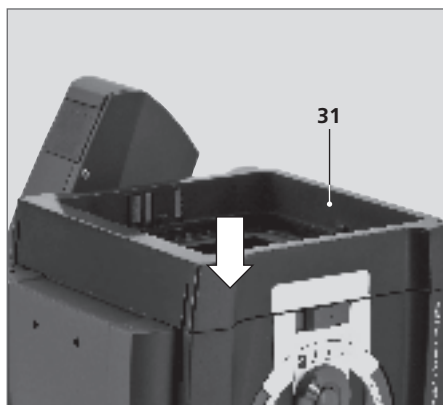

FILM MAGAZINE

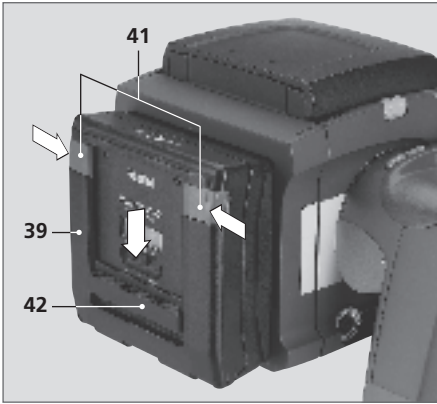

Opening the magazine

Push gripper ridge **42** for laminar drawslide all the way in the direction of "magazine change/turn" to close the drawslide. Press the two lateral releases **41** and swing down magazine back **39** as shown.

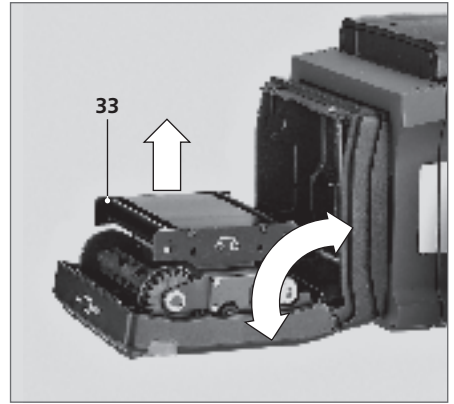

Removing film insert

Pull film insert **33** against the light resistance of its magnetic holder upwards out of the magazine back (see illustration above).

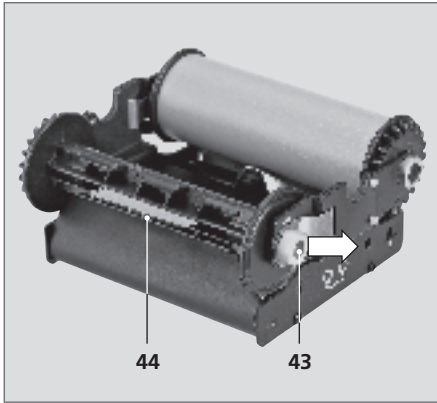

Loading the film magazine

Thanks to the symmetrical design of the film insert, the empty film spool need not be repositioned.

Use the film spool to press spring clip **43** outwards and insert the film spool in its holder so that the negative black inside of the paper is facing outwards.

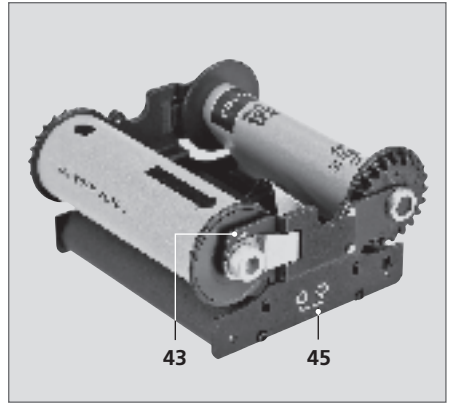



Make sure that the paper leader moves over the pressure plate to the empty spool **44** according to the symbol **45**.

Thread the paper leader straight into the empty spool **44**. Use the sprockets to wind the film taut and advance it until the arrow on the paper leader is aligned with the index ▲ of spring clip **43**.

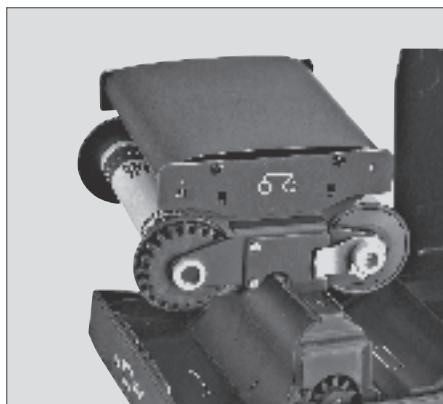
FILM MAGAZINE



Positioning the film insert

Place the loaded film insert in the magazine so that the full film spool faces the symbol  and the empty spool the symbol .

Closing the magazine

Close the magazine until it clicks in place. Film loading resets the frame counter to 00. The basic display will appear as soon as the LC display is switched on (see page 21).

Enter the film type and speed given on the film box (see page 23).

Push gripper ridge 42 up as far as it will go. This opens the drawslide.

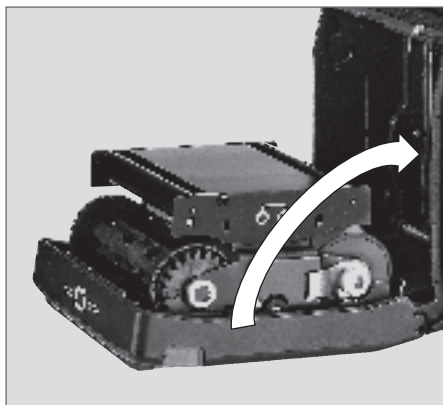

As long as the drawslide is not fully open, "SLIDE" will appear on the LC display, and the shutter cannot be released. "SLIDE" will appear only when the magazine is attached and the camera is switched on.

Film advance

Pressing the shutter release once will automatically advance the film to frame 01.

The LC display will show the frame number under EXP.NO.

The frame counter will advance with every exposure, up to 16 with size 120 film, up to 32 with size 220 film.



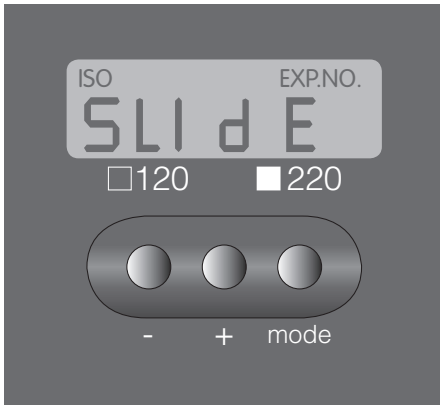

LC Display

The LC display **40** at the back of the magazine reflects the most important functions and conditions of the magazine.

Switching the LC display on

With the camera ON, lightly press the shutter release. The LC display will remain active as long as the camera is switched on. About 20 seconds after the camera has shut down, the LC display will be switched off automatically.

With the camera OFF or the magazine removed, press MODE button. If no button is pressed, the display will automatically switch off after about 20 seconds. All settings will remain in memory.

X Note

Very high or low temperatures may affect the legibility of the display.

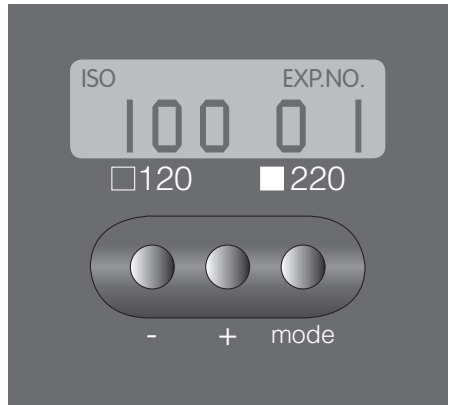

Basic display

The basic display appears as the LC display comes on. It shows the last settings put in memory, after a change of batteries (see page 26) the default settings.

Default settings

After a change of batteries, the memory will be reset to defaults.

- » Film speed to ISO
- » ISO speed to 11
- » Frame counter to 100
- » Film type to 120
- » No frame number on camera display (oFF)
- » Single-frame film advance (run)





Error detection

The LC display shows "Error" (see Fig. above)

- » when the shutter release is pressed without film in the camera
- » in the case of film advance malfunctioning.

The "Error" display will disappear after about one second.

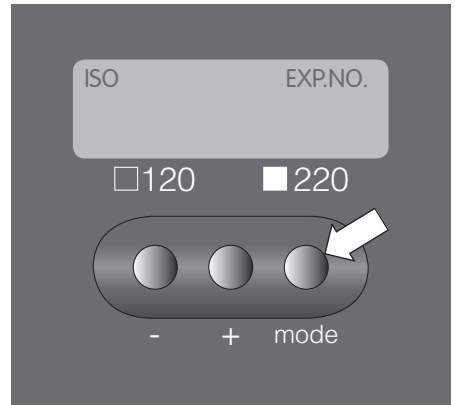

MODE button

The MODE button allows the following functions to be selected in this order:

- » **iSo/din**
Film-speed display mode
(see page 23)
- » **120/220**
Film type to 120 (see page 23)
- » **oFF/run**
Frame number in camera display
ON/OFF (see page 21)
- » **Run/StoP**
Film advance during multiple exposures
ON/OFF (see page 24).

To choose your settings, press "-" button or shutter release. The display changes to basic (see page 21).

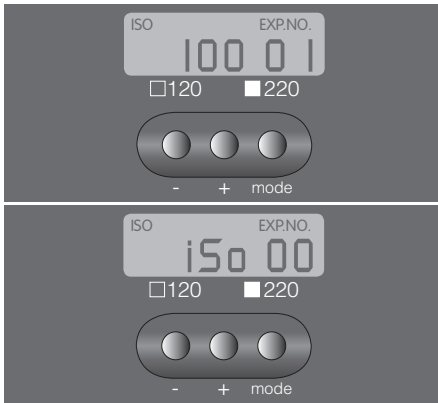

Presetting the film-speed display mode

Press MODE button once. iSo or din appears on the LC display. Pressing the “+” button, you can switch over between the ISO and DIN display modes.

Return to basic display (see page 21).

Entering the film speed

In basic display, incrementally reduce film speed pressing “-” button or increase it pressing “+” button.

In the ISO display mode, possible settings are from ISO 25 to ISO 6400, in the DIN display mode from DIN 15° to DIN 39°.

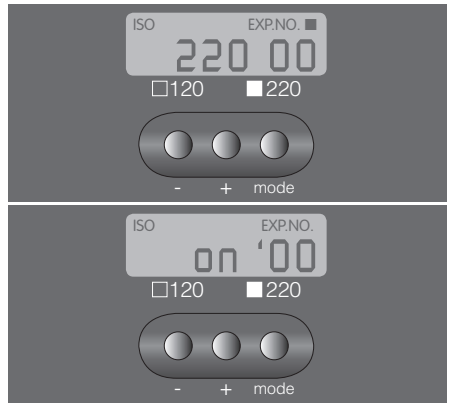

Presetting the film type

Press MODE button twice. Either 120 or 220 appears on the LC display. Pressing the “+” button, you can switch over between the two film types.

Return to basic display (see page 21).

For size 220 film, the square symbol ■ will light continuously on the LC display behind EXP.No.



Multiple exposures

Disabling film advance

Press MODE button four times. The LC display shows "run". In this setting, the film will be advanced normally after every exposure.

To disable film advance in the magazine, press the "+" button. The LC display shows SToP. The film will not be advanced after the exposure.

With film advance disabled (SToP), the number of individual exposures will be displayed below EXP.No. instead of the actual frame number.

Return to basic display (see page 21). The number of individual exposures EXP. appears on the LC display.

Enabling film advance

Press the "+" button before the last of the multiple exposures. The LC display shows "run" beside the number of multiple exposures. When "run" disappears, press the shutter release so that the multiple-exposure frame is advanced. The LC display shows the basic display.



Alternatively:

Before the last of the multiple exposures, press the MODE button four times. To re-enable film advance in the magazine, press the "+" button. The LC display shows "run". Return to basic display (see page 21).

Focusing screen and viewfinder mask

The High-D focusing screen in the viewfinder of your Rolleiflex Hy6 has orientation aids for horizontal and vertical 4.5 x 6 cm photography.

In addition, the viewfinder mask can be used for framing, which makes framing horizontal or vertical 4.5x6 photography even easier.

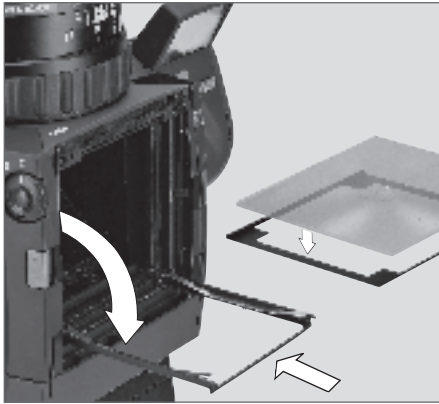

Inserting the viewfinder mask for the 4.5cm x 6.5cm format

Remove finderhood from camera, unlock focusing-screen frame by withdrawing buttons 6, swing up and remove focusing screen. Be careful not to touch its surfaces!

Place camera on its back as shown above. Place focusing screen with its matte side facing inside between the edges of the viewfinder mask. Slide viewfinder mask with focusing screen into focusing-screen frame. Close focusing-screen frame until it clicks in place and replace finderhood.

Changing negative size or magazine

Push gripper ridge 42 all the way in the direction of the arrow "magazine change/turn" to close the drawslide. Pull magazine straight towards the rear out of the adapter frame.

To change from horizontal to vertical format (or vice versa), turn magazine through 90° until the corresponding yellow format symbol can be seen at the top.

Insert magazine straight into magazine frame until it clicks into place. Move gripper ridge

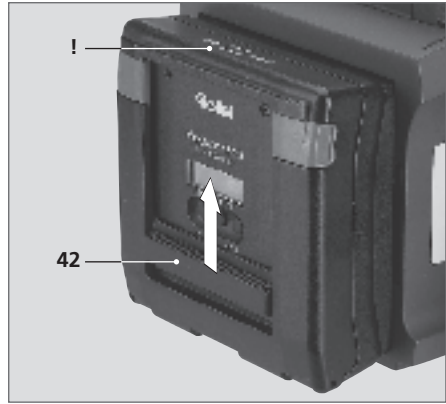

42 up. This will open the drawslide, lock the magazine on the camera and release the shutter button.

Removing the exposed film

After the last frame, the film is automatically wound up. Open the magazine back and remove the film insert. Take out the exposed film and seal it. Replace the film insert and press the magazine back until it locks.

X Note

Before opening the magazine back, **be sure** to move the gripper ridge in the direction of the arrow "magazine change/remove insert" as far as it will go. Failure to do so may damage the laminar drawslide.

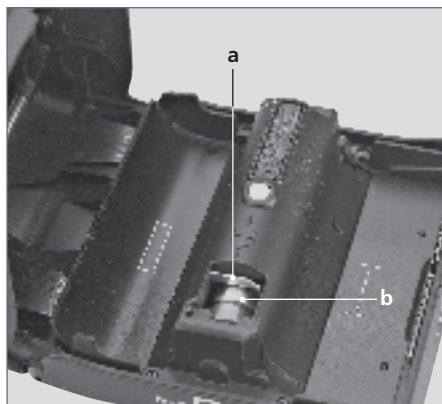

Changing batteries

The batteries are exhausted when the LC display is hardly legible.

Push gripper ridge all the way in the direction of the arrow "magazine change/turn". Press the two lateral releases and open the magazine. Remove the film insert.

Push battery spring *a* away from the batteries and remove exhausted button cells from battery compartment *b*. Dispose of exhausted batteries with due regard for the environment. Insert two new 1.55V button cells observing their polarity -  +.

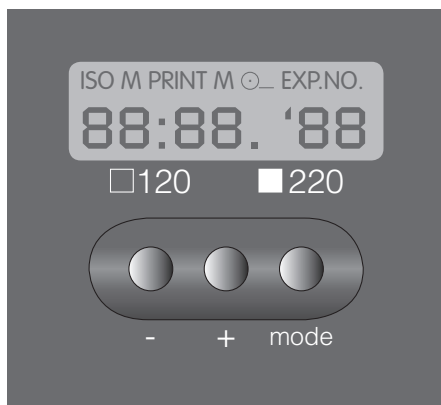

As the batteries are loaded, all segments of the LC display should light up simultaneously for about one second. Should this check fail to appear, briefly push battery spring *a* away from the batteries and let go.

Insert film magazine and close magazine until it clicks into place. Push gripper ridge up to open the drawslide.

After changing batteries, the memory will be returned to its default setting (see page 21), and the film speed has to be entered again (see page 23).

Make other settings as required.

Problem	Cause	Remedy
LC display hardly legible.	Magazine batteries exhausted.	Change batteries (see page 26).
Back cannot be closed.	Drawslide is open.	Push gripper ridge fully down in direction of arrow.
Magazine cannot be removed or opened.	Drawslide is open.	Move gripper ridge fully down.
Magazine cannot be attached.	Lateral hooks on magazine are locked. Film guiding strip still in place.	Carefully push out hooks by hand using a pointed object. Film guiding strip is detachable.
Shutter release blocked with magazine attached.	Drawslide closed.	Push gripper ridge fully up.
LC display shows "Error".	Shutter released without film in camera or film advance malfunction.	Load film following instructions (see page 19/20).
Size 220 film is only partially exposed.	Film type has not been entered.	Enter film type (see page 23).
Magazine fails to respond to MODE +/- button.	Power supply interrupted.	Remove batteries and reload (see page 26).

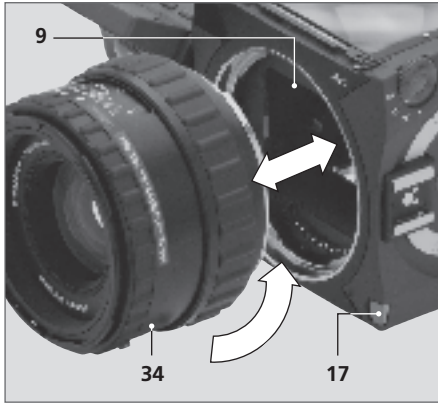

Changing lenses

Press button **17** and remove lens **34** from camera bayonet, turning it counterclockwise. Align red index of interchangeable lens with red dot **9** and lock by clockwise rotation.

For available interchangeable lenses see page 82/83.

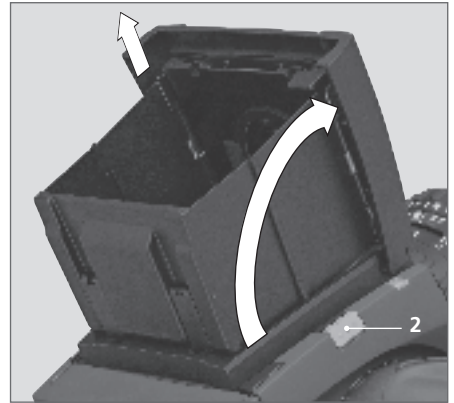

Changing viewfinders

Open standard finderhood, press both release buttons **2** and lift finderhood off. Proceed in the reverse order to mount the interchangeable viewfinder that will lock automatically.

As a 45° prism finder or a 90° High-Eyepoint finder is mounted, the viewfinder display is automatically switched to laterally correct reading of viewfinder information!

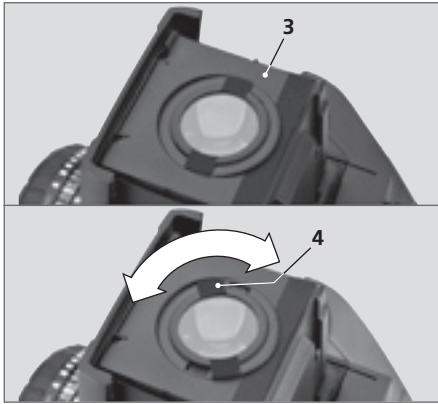

Changing magnifiers for eyeglass wearers

To allow focusing without eyeglasses, the magnifier of the folding hood can be changed for one making allowance for the wearer's visual defect within a range of +2.5 to -4.5 dpt (as referred to the dioptric value of the wearer).

To change magnifiers, hold flap **3** laterally between thumb and index finger, at the same time pressing the lateral panels of the finderhood against the flap. Unlock magnifier **4** by counterclockwise rotation and lift it off. Insert interchangeable magnifier into magnifier holder and lock, turning it clockwise.

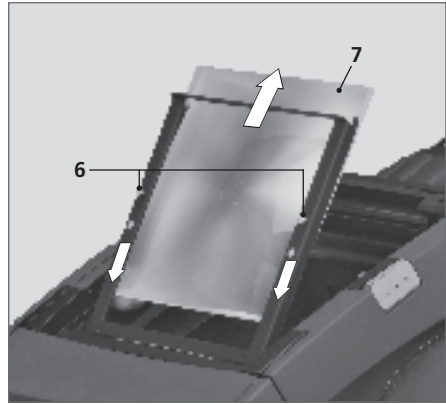

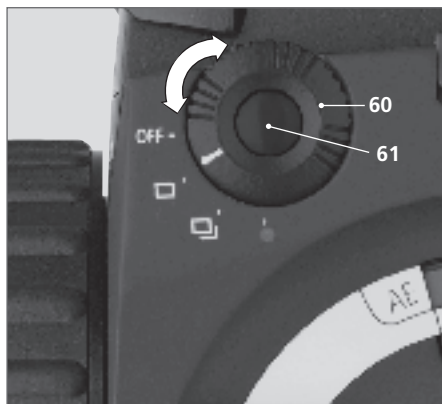

Changing focusing screens

Remove finderhood, pull back the two catches **6** and carefully swing frame up. Withdraw focusing screen **7** and keep it in a dry place. Do not touch its surfaces – therefore grip it only at the edges! Slide interchangeable focusing screen (with its matte side facing the mirror!) between retaining tabs and springs. Close hinged frame, pull it back slightly and let it click into position on both sides.



Switching the camera on and off

With the master switch **60** on OFF, the camera is switched off and cannot be activated by inadvertent actuation of one of its controls.

When the master switch is set to either  for single-frame shooting or  for continuous shooting, the camera can be activated only with the aid of its shutter release. As long as the camera is deactivated, the displays **8** and **24** will remain blank.

In its default setting, the camera will stay on for about three minutes. The camera will then shut down. All camera settings are stored. Use of any of its controls will extend standby by another three minutes.

Single-frame shooting

With the master switch set to , any depression of the shutter release will trigger an exposure. For the next exposure, first reduce pressure on the shutter release.

Continuous shooting

With the master switch set to , the camera will keep shooting for as long as its shutter release is kept depressed. With roll film, full battery, normal temperature (20°C) and shutter speeds faster than 1/250 s, up to about two frames per second are possible.

Shooting modes/Custom functions Shooting (see page 54)

Set master switch to red dot. After pressing shooting-menu button **61**, the following shooting modes can be selected with scroll dial **25**:

- » Single frames (single)
- » Continuous shooting (continuous)
- » Exposure bracketing
- » Self-timer
- » Focus bracketing.

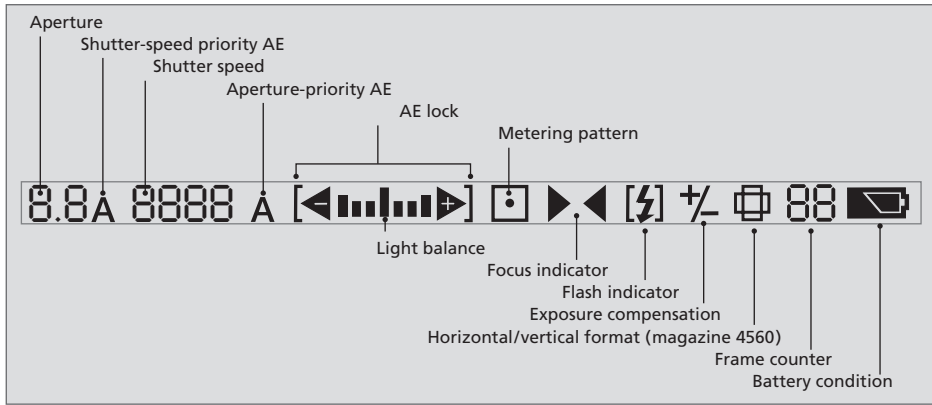

Viewfinder information

The illuminated LC control centre in the viewfinder provides comprehensive information on all relevant shooting and camera data.

The most important information is:

- » **Exposure mode**
- » **Shutter speed and aperture**
- » **Light balance meter**
- » **Exposure metering pattern**
- » **Focus indicator**
- » **Flash indicator**
- » **Battery condition**

HANDGRIP DISPLAY

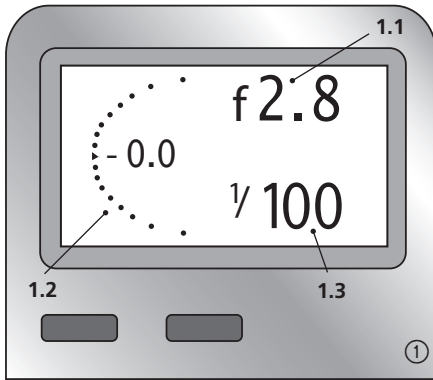

Handgrip display

With the camera switched on, light depression of shutter release **21** will show all important shooting data at a single glance on the large handgrip display. The basic display illustrated above will appear: 1.1 = aperture, 1.2 = light balance, (indicating over or underexposure) 1.3 = shutter speed.

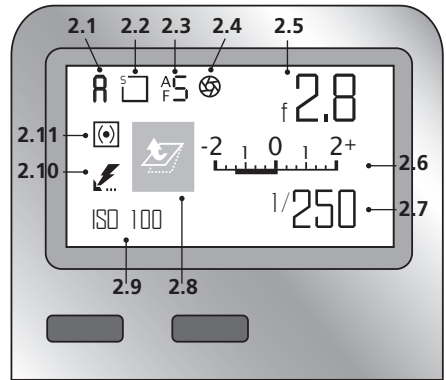

As one of the selector switches is set to one of the red indices, the handgrip display will change, and additional detailed information will appear as shown above, right.

The following data are presented:

- » **Exposure mode (2.1)**
- » **Single or continuous shooting (2.2)**
- » **Autofocus mode (2.3)**
- » **Shooting aperture (2.4)**
- » **Aperture (2.5)**
- » **Exposure compensation/Light meter (2.6)**
- » **Shutter speed (2.7)**
- » **Mirror lock (2.8)**
- » **ISO speed (2.9)**
- » **Flash mode (2.10)**
- » **Metering pattern (2.11)**

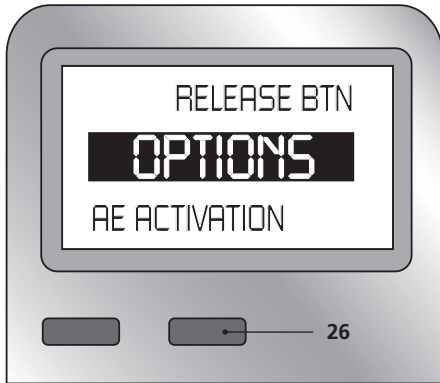

Menu button **26** allows various default settings to be varied:

- » **LCD BACKLIGHT** **AUTO ON/OFF**
- » **LCD CONTRAST** **CONTRAST LO/HI**
- » **ACOUSTIC SIGNAL** **ON/OFF**
- » **POWER SAVE** **ON/OFF**
- » **AE ACTIVATION** **RELEASE BTN/MANUAL**
- » **GUI (GRAPHIC USER INTERFACE)** **AUTOMATIC/ENHANCED**

To set the desired option, use the menu scroll dials **21** and **25**.

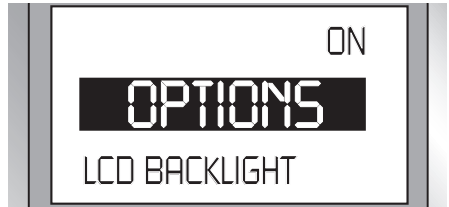

OPTIONS

LCD Backlight

This submenu lets you choose one of three illumination modes for the viewfinder and handgrip display:

ON = Illumination always on.

OFF = Illumination off.

AUTO = Pressing the shutter release will switch illumination on. It will remain on for as long as the camera is used. Approx. 15 s after the camera has been used, illumination will switch off automatically.

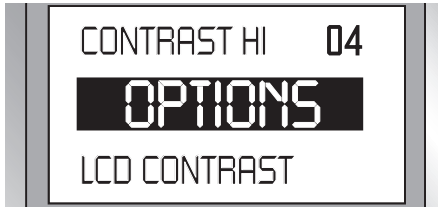

OPTIONS

LCD Contrast

Contrast of the handgrip display can be set between LO (Low) and Hi (High) with the aid of scroll dial **21**. Hi settings are possible from 00 to 16, Lo settings from 48 to 63.

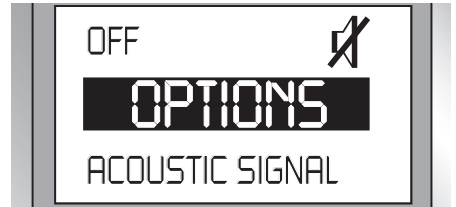

OPTIONS

Acoustic signal

Some digital backs give an acoustic signal to let you know when the back is ready for the next exposure. This can be muted with scroll dial **21**.

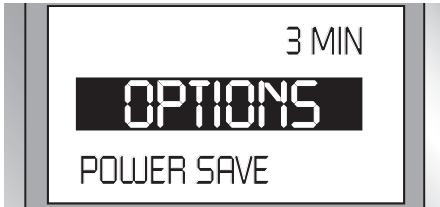

OPTIONS

Power save

This menu allows settings of 3, 5, 10, 20, 30 minutes and one hour (HR) as well as OFF. The default setting is 3. The camera will switch to standby after the time set and can be reactivated by lightly pressing the shutter release. In the OFF setting, the camera will stay switched on until it is turned off via master switch **60**.

Note: In the latter case, the battery may be deep-cycled!



OPTIONS

AE activation

Automatic exposure control can be disabled with scroll dial **21**.

In other words, aperture and shutter speed can be chosen freely. Only the light balance in both displays will keep you informed about exposure tendency. The AF-function is still working.

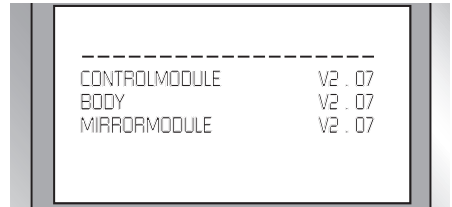
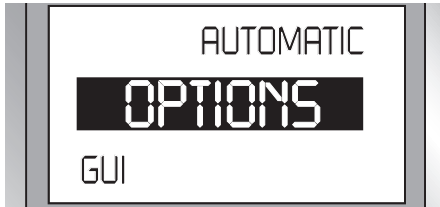

OPTIONS

GUI (Graphic User Interface)

There are two alternative settings:

AUTOMATIC (default) and ENHANCED.

In the ENHANCED setting, the handgrip display will always show *all* relevant shooting data.

+++	STATUS	+++
SUPPLY	VOLTAGE	V 7.3
BUFFER	VOLTAGE	V 11.7

+++	STATUS II	+++
FOCUS		7.2
TARGET		2.2
EXP METER	7.6	5.0
BACK SYNC		Film
BACK OUT		HI
BACK IN		HI

FOCUSING

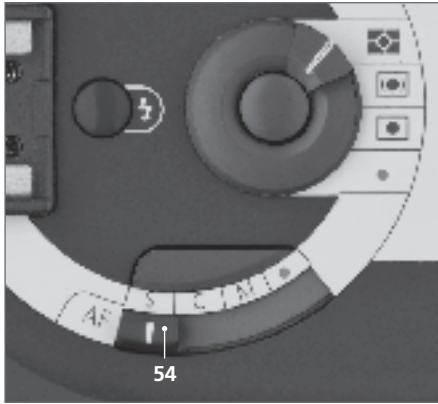

Focusing

The focusing selector **54** gives options of auto-focus (S = Single focusing, C = Continuous focusing) and manual focusing (M = focus indicator) as well as Advanced (→ red index).

To focus, press the shutter release lightly to its first stage. Only full pressure will trigger an exposure. To avoid inadvertent exposure, it is advisable first to practice with the two stages of the shutter release without any film in the camera.

In its standard version, the camera's focusing system uses a cross-type sensor.

X Note

Avoid the incidence of extraneous light on the focusing screen that might degrade focusing accuracy!

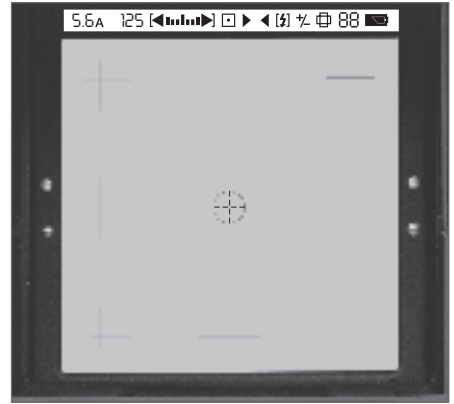

Closing the finderhood or using a prism finder is therefore recommended for tripod photography when no direct use is made of the viewfinder. The magnifier in its upper position may act like a burning glass and enhance the effect of extraneous light.

With manually focusing lenses, the camera in the autofocus mode (focus-mode switch set to "S" or "C") behaves as if it was set to focus indicator.

Autofocus and focus indicator will work properly only if the effective minimum aperture of the lens used is at least f/5.6. This should be noted above all when using a teleconverter or close-up accessories.

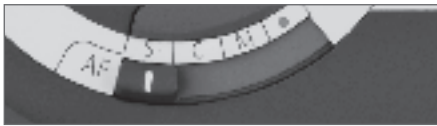
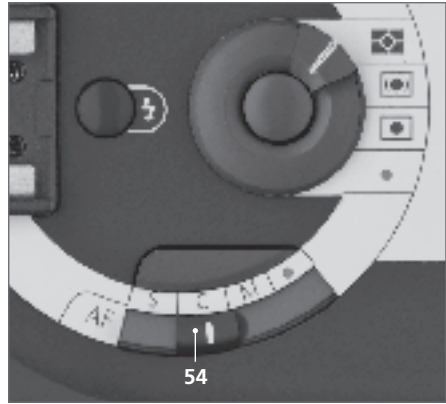
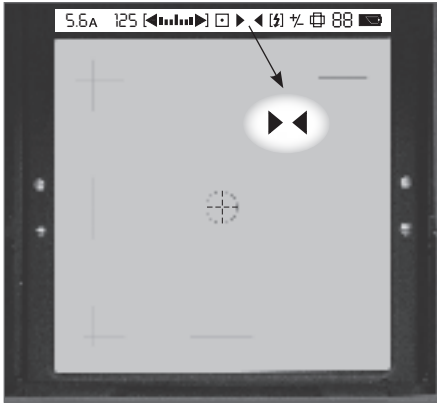

Single Focus (S)

Set focus-mode switch **54** to “S”. Place the cross-sensor symbol in the viewfinder over the subject to be focused (see illustration) and press shutter release **22** until a light resistance is encountered (stage 1). Your AF lens will now focus automatically. To repeat metering, let go of the shutter release and press it again lightly. Sharp focus has been detected when the two arrows of the focus indicator appear simultaneously.

Metering is impossible if only *one* arrow appears in the focus indicator. In this case, place the focus area over a well-textured detail of higher contrast at the same distance and trigger your exposure with the final framing. If necessary, fine-tune manually.

This function uses focus priority. In other words, exposure is possible only after focusing has been accomplished.

X Note

In low light, an integral IR (infrared) grid projector will aid the autofocus system.

Continuous Focus (C)

Set focus-mode switch **54** to “C”. Unlike in the single-focus mode, the autofocus is here active for as long as the shutter release is held at stage 1. The AF lens will then refocus as soon as the object detail moves out of the focus area.

This function uses release priority so that an exposure can be triggered at any desired moment, regardless of focusing status. In all other details, the mode is identical to Single Focus.

EXPOSURE METERING PATTERNS

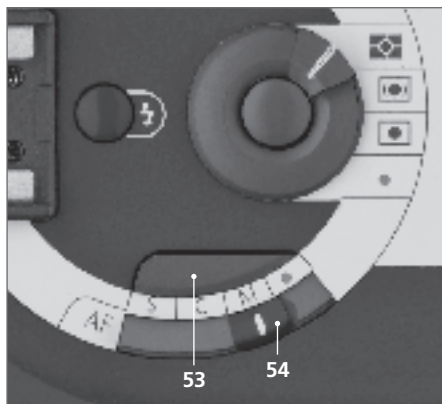

Manual Focusing (M)

(Focus Indicator)

Set switch **54** to M and focus by turning ring **11** of the lens. Check focus with the aid of the focus indicator. Place the focus area over the subject to be focused and turn ring **11** until the two arrows of the focus indicator light simultaneously. The arrows indicate the direction in which the ring should be turned.

See the table below:

Display	Focal plane
▶ ◀	Behind subject
◀ ▶	In front of subject
▶ ▶	On subject

All Rolleiflex 6008 PQ/PQS lenses can be used with the Hy6 with manual focusing.



Manual focusing is impossible if the two arrows cannot be brought to appear in the focus indicator simultaneously. In this case, focus on a well-textured subject of higher contrast at the same distance.

To re-enable autofocus, press menu button **53**.

X Note

With interchangeable lenses of longer than 180mm focal length coarse manual focusing will be required because in this case the focusing system may, for physical reasons, be in error.

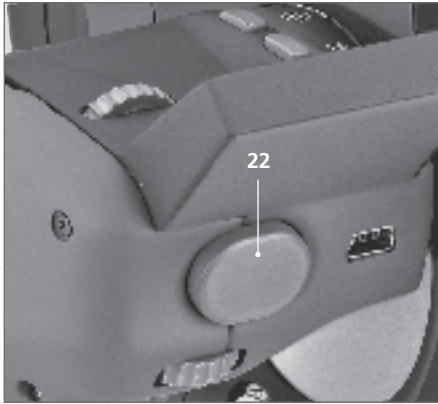

Exposure metering

With the camera ON, its exposure-metering system becomes active when the shutter release 22 is depressed lightly. The reading can be stored by keeping the shutter release in this position. AF is locked at the same time.

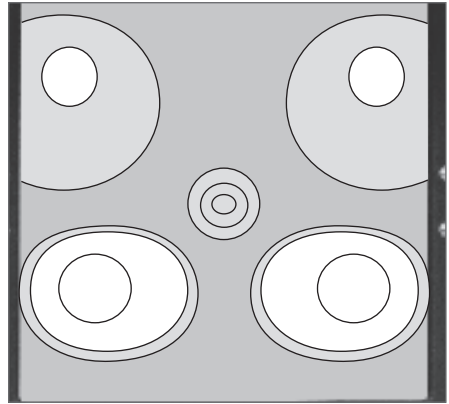

Multizone average metering

Seven silicon photodiodes located behind the reflex mirror meter the incident light. Arranged in five groups, they ensure well-balanced multi-zone readings that usually give excellent results.

For average light metering only the outer six diodes are active.

Outside the centre of the frame, this metering pattern gives added weight to the lower portions of the image as opposed, for example, to the sky in landscape photos.

See illustration above!



To use this metering pattern, set switch 57 to . The corresponding symbol will appear on the display.

EXPOSURE MODES

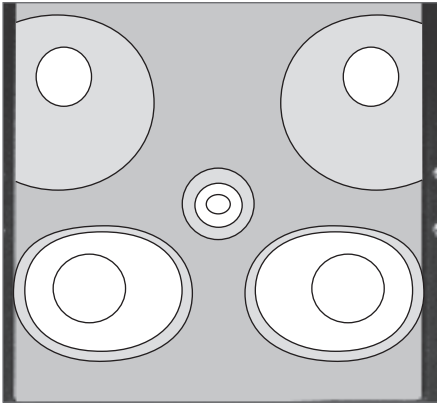

Centre-weighted multizone metering

Here all seven silicon photodiodes are active. 50% of metering sensitivity are concentrated on the centre of the frame. The remaining metering areas are weighted with also 50%. This metering pattern is recommended for shots in which exposure should be adjusted to a narrowly limited subject area.

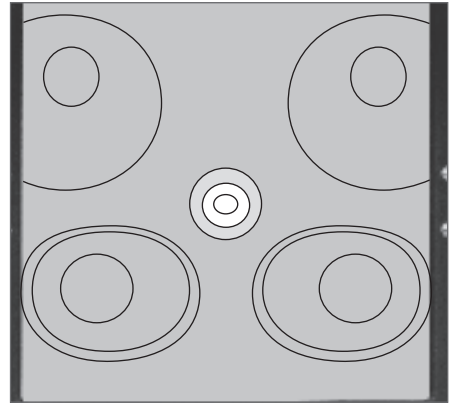

Spot metering

When shooting against the light or with high-contrast subjects, important subject detail may be metered with the central spot-metering cell alone (< 1% of image area, as referred to 6x6cm format). Brightness in the 5mm centre circle is then weighted with 100%. However, using spot metering requires a certain measure of experience.



Set switch **57** to .



Set switch **57** to  to activate this mode. The corresponding symbol will appear on the display.



Programmed AE (P)

Set aperture ring **15** of an AF lens to "A" (not applicable to AFD lenses) and selector switch **59** to "P". In the viewfinder display, "A" will appear next to the aperture and shutter-speed display. The camera will now select a combination of aperture and shutter speed suited for the lighting conditions. In the default setting, the program is biased for fast speeds to reduce to a minimum the risk of blur due to camera shake. Also in the default setting, the program is biased for shutter-speed priority at 1/125 s.

If the lighting conditions have exhausted the available margin of apertures and shutter speeds, the light balance will show the deviation from correct exposure (within ± 1 EV, in 1/3 increments).

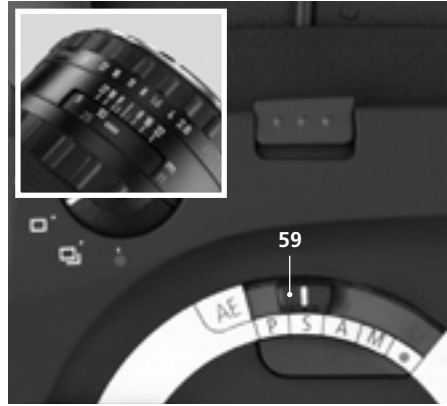

Shutter-speed priority AE "S"

Set selector switch **59** to "S" and select desired shutter speed – in 1/3 increments – turning dial **25**. Turn aperture ring **15** to "A". Not applicable to AFD lenses. On the camera display, "A" will appear next to the aperture. If the available margin of apertures is exhausted due to the lighting conditions and the shutter speed selected, the aperture display and the light balance will show the deviation from correct exposure (within ± 1 EV, in 1/3 increments).

EXPOSURE MODES

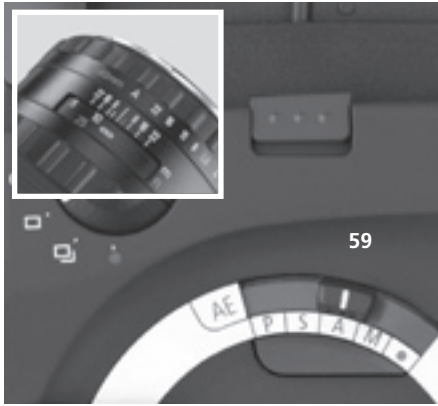

Aperture-priority AE "A"

Set selector switch **59** to "A", unlock aperture ring **15** pressing release **35** and choose the desired aperture on your AF lens – in 1/3 increments. (Not applicable to AFD lenses). "A" will appear next to the shutter speed on the camera display. If the margin of shutter speeds is exhausted due to the lighting conditions and the preset aperture, the shutter-speed display will blink, and the light balance will show the deviation from correct exposure (within ± 1 EV, in 1/3 increments). If the difference is greater than 1 EV, the light balance will also blink.



Metered Manual "M"

In this mode, any desired combination of aperture and shutter speed may be used. Set selector switch **59** to "M" and use aperture ring **15** plus scroll dial **25** to manually select shutter speed and aperture (AF lenses). Align the exposure indicator with the centre index of the light balance in viewfinder display. Deviations are displayed in 1/3 EV. If the difference is greater, the light balance will also blink. Setting aperture and shutter speed on AFD lenses is possible only with scroll dials **21** and **25**, respectively.

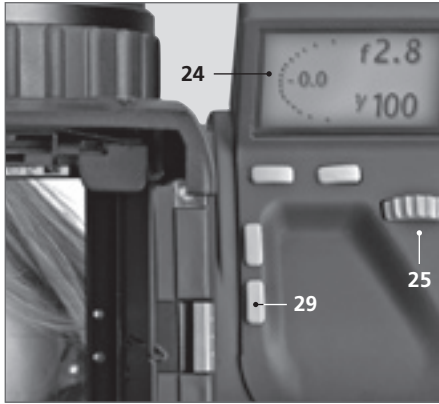

Exposure compensation

Keep button **58** depressed and use dial **25** to set the desired compensation over a range of ± 5 EV. The amount of compensation is displayed with \pm in the viewfinder as well as on the display of grip **24**.

X Note

The camera should be in the auto mode.

Depth-of-field preview

To preview depth of field, press stop-down button **29**, and the preset aperture will jump into position. Depth of field can best be judged with the magnifier in its top position.

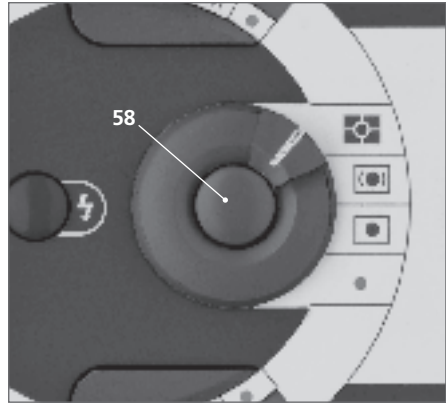

Compensation of extraneous light

Extraneous light incident through the open folding hood is factored into the measurement and compensated up to a ratio of extraneous-to-metered light of approx. 16 : 1. Compensation is independent of the type of viewfinder used.

If the viewfinder image is viewed through the folding hood without a magnifier, the focusing screen should be properly shaded during metering to avoid the incidence of extraneous light (e.g. light sources, especially fluorescent lamps). During long time exposures, the folding hood should always be closed.

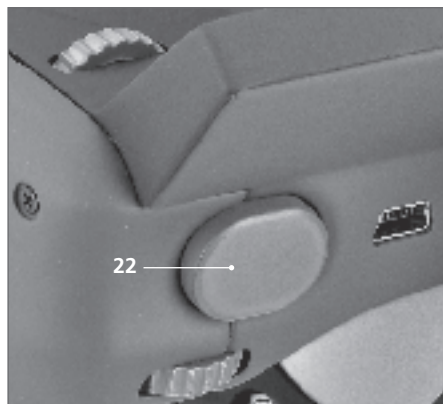

Tripping the shutter

Brief light depression of the shutter release 22 will switch on both the viewfinder and the handgrip display.

The shutter release is of the two-stage type. Stage 1 serves for autofocus and exposure metering, stage 2 for exposure triggering.

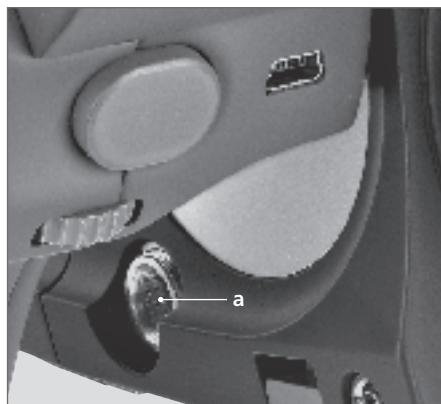

Using a cable release

Plug cable release into socket a. For exposure, press START button. The film will be automatically advanced after exposure. The START button on the cable release is equipped with the similar function of the START button of the camera.

X Note

When using a cable release, automatic focusing is not possible in the continuous-focus mode (release priority).

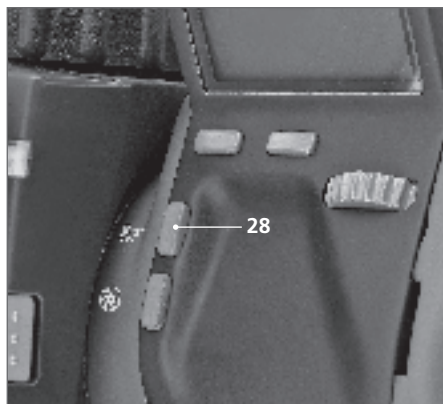

Locking up the mirror

To cut out even the slightest vibration during exposure, especially with long lenses or close-ups, it is advisable to lock up the mirror. To do this, briefly press button **28** identified by a mirror symbol: The mirror will swing up. Then press the shutter release. The shutter lag is only a few milliseconds.

Do not make any further adjustment while the mirror is up because exposure metering is then disabled. If the camera shuts down or if it is switched off via its master switch, the AE values determined will be stored in the memory.

If no further exposure with mirror lock is planned, press button **28** again: The mirror will swing back to its normal position without any exposure.

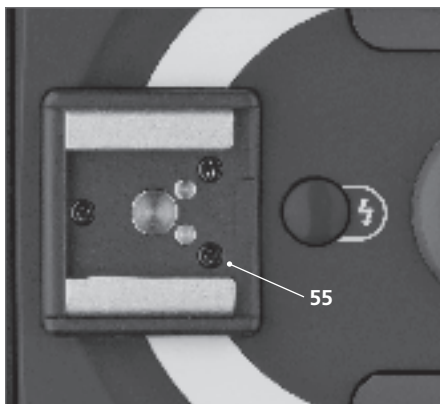

Flash photography

Your Rolleiflex Hy6 is fully X-synchronized at all shutter speeds up to $1/500$ s (up to $1/1000$ s with PQS lenses). Flash units can be connected either to hot shoe **55** or PC contact **19** with (parallel-connected) standard 3mm socket. The camera offers the following flash options:

- » Manual flash (aperture chosen as a function of subject distance).
- » Dedicated flash (TTL flash metering and control) with dedicated SCA-3562 flash adapter and suitable Metz flash units.
- » The TTL-flash sensor incorporated in your camera will meter the light in the "multi-zone" function.
- » Different degrees of reflection of digital backs are transmitted to the camera via electrical interfaces and will be taken into account automatically.

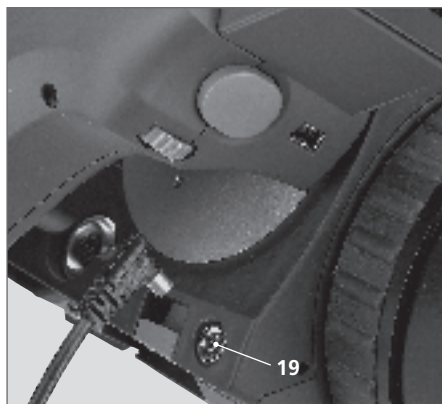

X Note

Since studio flash units may have considerably longer response and burning times than compact or handle-mount flash units, slower shutter speeds than $1/250$ s may cause the flash to fire too late and light beyond the end of shutter-open time. Please consult the operating instructions supplied with your flash equipment.

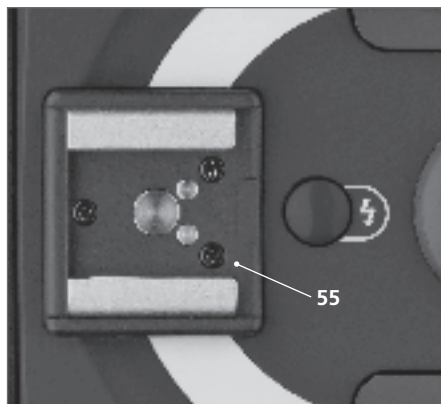

Setting the type of flash synchronisation

Keeping button ⚡ beside the hot shoe **55** depressed will make "Flash" appear on the handgrip display **24**. It is then possible to set the desired type of flash synchronization using the scroll dial **21**:

Due to the use of between-the-lens shutters, flash is synchronized with all available shutter speeds. At speeds faster than $1/250$ s, there will be no difference between leading and trailing synchronisation.

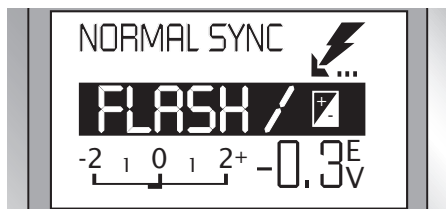

NORMAL SYNC

The flash fires immediately after the shutter has opened, i.e. at the beginning of exposure (default setting).

Additional EV corrections can be made in 1/3 increments within -3 to +3 EV with the aid of scroll dial 25.

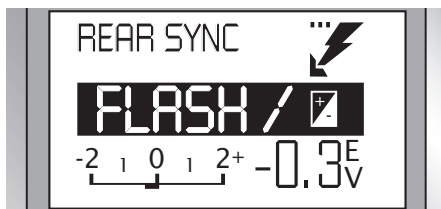

RARE SYNC

The flash fires 3 ms before the shutter closes, i.e. at the end of exposure.



Manual flash without SCA adapter

Switch your flash unit off and connect it to the camera's hot shoe or PC terminal. In this case, the camera will not detect your flash unit and behave as if no flash were connected. On AF lenses or the camera (with AFD lenses), set the aperture as required by your flash unit.

Autoflash units control the light output required for an aperture set on flash and camera via their integral sensor. With simpler flash units, the flash aperture will have to be determined as a function of subject distance (table on flash). For details, please see the instructions of your flash unit.



Using a dedicated SCA-3562 adapter

In conjunction with dedicated flash units and an SCA-3562 (or SCA-356) adapter, the TTL flash-metering feature of the camera can be used. Switch your flash unit off, attach the adapter, connect it to the camera and set it to TTL. During exposure, the sensor incorporated in the camera will meter the light reflected from the film or sensor surface and control flash duration according to film speed and ambient light level. The result is optimum exposure accuracy within a range of ISO 25 to ISO 1600.

Camera and flash unit interchange the following data via the flash adapter:

- » Focal length of AF lenses to control the flash reflector
(Note: For technical reasons, focal lengths are converted to 35mm equivalents).
- » Lens-aperture and film-speed settings to control the autoflash unit.
- » Reading of flash compensation in suitable flash units.
- » Control of AF preflash

Automatic flash photography with SCA adapter in poor light

Poor light means that the limit of flash apertures and basic flash speed would have to be exceeded to obtain correct exposure. As long as there is sufficient light, the automatic control will perform as described under "Automatic fill flash with SCA adapter".

Programmed AE flash

If the light is poor without the available flash apertures (see table) having to be exceeded at the default setting of the basic sync speed of $1/60$ s, the camera will automatically fire the flash to make up for the missing light.

Aperture AE flash

If the ambient light is insufficient for correct exposure at the preset f-stop and the basic sync speed of $1/60$ s, the camera will automatically fire the flash to make up for the low light level.

X Note

Use wide apertures only for long distances, or correct exposure will become difficult due to the switching times of flash units.

Shutter-priority AE flash

Select the desired shutter speed. In poor light, full use will first be made of the available flash apertures (see table). The flash will then automatically add the amount of light still missing. Flash apertures start with the values given in the table, depending on film speed.

ISO	25	50	100	200	400	800	1600
Aperture	2.8	3.5	4.0	5.0	5.6	7.1	8

Fill-in autoflash with SCA adapter

If there is sufficient light and no flash is needed, the flash will not fire. However, if the flash is to be used for fill-in in one of the three automatic exposure modes after all, this option is available. (also see the instructions of your unit's manufacturer).

This auto fill mode is of particular interest for shots in which the foreground should be filled in, while the background should remain untouched due to the limited flash output (e.g. in outdoor photography).

Manual flash exposure control

If none of the three automatic exposure modes has been selected, exposure is controlled separately for the ambient light and the flash. Exposure by ambient light can be controlled as described under "Metered manual". In addition, TTL metering will control flash output.

Flash-output compensation is possible with the aid of the compensation switch of the flash unit. The camera's exposure compensation will then affect only metering of ambient light.

SHOOTING MODES

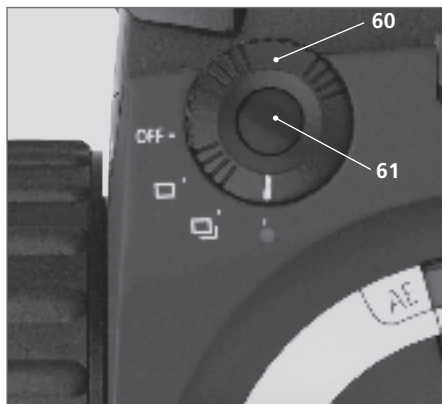

Set master switch **60** to the red index and briefly press the shutter release to stage 1. This will activate the viewfinder and handgrip displays.

With menu button **61** depressed, the above display will appear on the handgrip.

Clockwise rotation of dial **25** gives access to the following menu items:



SINGLE

Single-frame photography

In this mode, every depression of the shutter release will trigger an exposure and – in conjunction with a film magazine – an advance cycle.

Press the shutter release again for the next shot.

X Note

The new shots will be saved as menu button **61** is released.



To fine-adjust the submenus for Bracketing and Self-timer, use aperture dial/scroll dial 21.



BRACKETING

Bracketing

Above all with slide film, bracketing allows carefully controlled exposure compensation. It is available in both the auto and the manual mode and – in addition to a normally exposed picture – allows the following variations:

- 3 exposures -1/3, 0, +1/3
- 3 exposures -2/3, 0, +2/3
- 3 exposures -1, 0, +2
- 5 exposures -4/3, -2/3, 0, +2/3, +4/3
- 5 exposures -2, -1, 0, +1, +2

To choose the desired configuration, use scroll dial 21.

Keep the shutter release depressed until the series of exposures has been completed. Premature release of the shutter button will abort the series.

X Note

If the margin of available shutter speeds or apertures should not be wide enough to accommodate the entire bracketing series, the shutter-speed or aperture plus the +/- symbol will blink as a warning.



CONTINUOUS

Continuous shooting

In this mode, the camera will expose one frame after another for as long as the shutter release is kept depressed. When using a film magazine, maximum advance speed is 2 fps at normal temperature (20° C), with a full battery and at shutter speeds faster than 1/250 s.



SELF-TIMER

Using the self-timer

To start the self-timer, press the shutter release. The delay is shown on the display. The following delays can be set with scroll dial **21**: 1/4, 1/2, 1, 2, 4, 8, 16, 32, 64 and 128 seconds.



FOCUS TRAP

Freeze-frame focus

Freeze-frame focus is possible only with manual focusing. Set switch **54** to the red index. Then hold down menu button **61**, select "Focus Trap" with scroll dial **25**, focus and press the shutter release all the way and the function will be activated.

AF modes S and C are disabled in this mode.

If you wish to reproduce sharply a certain point or subject within the frame, as in sports or fashion photography, focus manually on the corresponding location (be sure to use a tripod!). The camera will automatically fire as soon as an athlete or model crosses this focal plane. In this mode, AF lock is no longer controlled by the shutter release.



BRACKETING F
(Focus bracketing)

There is a choice of 3, 5, 7 or 9 exposures per series. If you choose five bracketing exposures, for example, one will be made with the focusing determined by AF, plus two each in 1/1 and 2/1 focus steps in front of and behind the optimum focal point determined. The camera will adjust the plane of focus automatically from exposure to exposure.

To do this, the mirror is locked up, and the exposures are made with autofocus and shutter interacting. A tripod should be used.



ULTRA FAST
Ultra Fast (Instant release)

In photographic practice, a minimum shutter lag may be required to capture a subject at the decisive moment – for example, if the camera is tripod-mounted, facing the subject and triggered by a photoelectric sensor. To make this possible, exposure metering and mirror lock are performed in advance.

To select the Ultra Fast mode, keep button **61** depressed and use dial **25** to select “ultrafast” on the display. As a result, the light will be metered, the reading put in memory and the mirror locked up. Depression of the shutter release will now lead to exposure with a delay of only 3 – 4 ms. If a PQS lens is used, the shutter lag will only be about 2 ms.

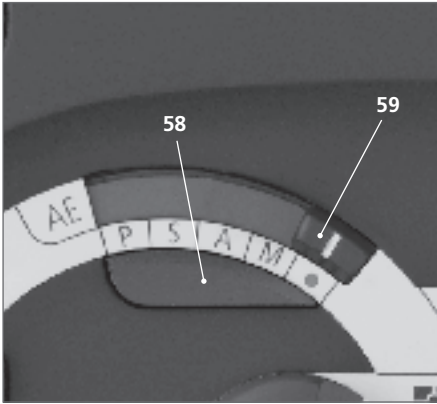

Set exposure-mode selector **59** to red index, switch camera on with master switch **60** and briefly depress the shutter release to stage 1. Viewfinder and handgrip displays are activated.



With menu button **58** depressed, the above display will appear on the handgrip.

Clockwise rotation of dial **25** gives access to the following menu items:



MANUAL

Metered manual

In this mode, any desired shutter speed and aperture can be set – for example in critical lighting conditions or if a precise amount of over or underexposure is desired. The light balance on the camera displays will keep you informed of the deviation from the exposure the camera has determined so that you will always know how far your manual setting is away from normal exposure.



APERTURE PRIO.

Aperture priority

This mode is ideal for the creative use of depth of field, a small aperture resulting in good depth of field from fore to background, a wide aperture in selective focus, emphasizing the main subject by blurring the background.



SHUTTER PRIO.

Shutter-speed priority

Ideal for shooting moving subjects. You decide how sharp you want subject motion to be captured: with pin-point sharpness (frozen) due to a fast shutter speed or with a slower speed that graphically emphasizes motion in the image.



PROGRAM

Programmed AE

In this mode, the camera will automatically select a combination of aperture and shutter speed to suit existing lighting conditions – biased for a fast 1/125 s to reduce the risk of camera shake. Ideal for rapid shooting when there is no time for lengthy settings.

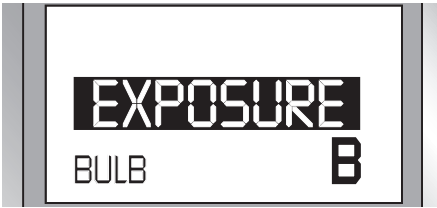

BULB

Bulb exposure

The shutter remains open for as long as the shutter release is kept depressed. During exposure, the display shows □.

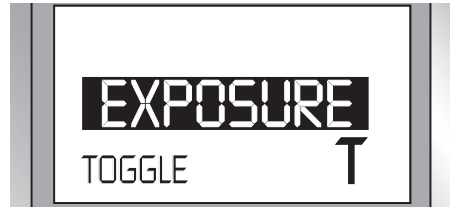

TOGGLE

Time exposure

Unlike in the B mode, the shutter here remains open even after you let go of the shutter release. It will close when the shutter button is pressed again. Exposure metering is not possible in either of these modes. During exposure, the display shows □.

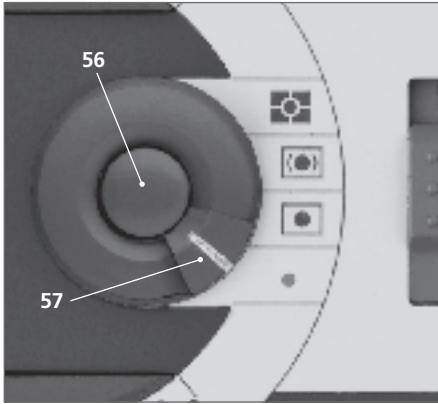

Set metering-pattern selector **57** to the red index. If necessary, switch camera on with master switch **60** and briefly press the shutter release to stage 1. This will activate the viewfinder and handgrip displays. Keeping menu button **58** depressed, you can correct selected EV values by turning shutter-speed dial **25** and vary ISO values from ISO 12 – 3200 with the aid of aperture dial **21**.

Exposure compensation is very useful in all of the autoexposure modes where it can be used to shift exposure very selectively. It allows normal exposure to be shifted in a very selective manner.

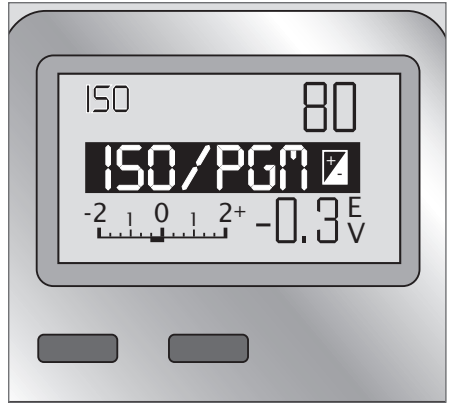

X Note

Button **56** is permanently enabled, allowing you to vary ISO and EV values any time during the shoot.

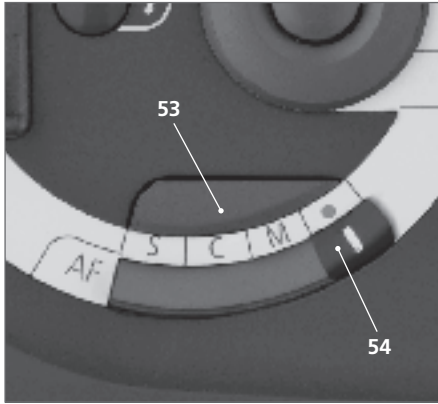

Set focus-mode selector **54** to its red index. If necessary, switch camera on with master switch **60** and briefly press the shutter release to stage 1. This will activate the viewfinder and handgrip displays. Keeping menu button **53** depressed, turning dial **25** will give access to the following focusing modes:



MANUAL

Manual focusing

For special shooting situations in which manual focusing may seem more appropriate.

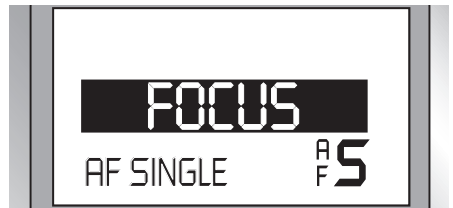

AF-SINGLE

Focus priority

In this mode, an exposure can be triggered only after focusing has been completed and the two focus arrows in the viewfinder are facing each other – your best guarantee for sharp pictures. Keeping the shutter release lightly depressed to stage 1 after focusing has been completed, you can easily reframe without refocusing (AF lock).



AF-CONTINUOUS

Release priority

The ideal focusing mode for moving subjects, since the camera will keep the subjects in sharp focus. Exposure can be triggered at any time so that you are in full control of exposure timing.



Shooting at low temperatures

Below -10°C it is advisable to keep the battery warm by carrying it in an inside pocket and loading it only shortly before shooting. In extreme conditions (in polar regions, cooling chambers, refrigeration laboratories), the camera will also need protection, i.e. insulation.

Shooting in difficult lighting situations

The camera's autoexposure system is fully operational in conjunction with any interchangeable lens, filter, extension ring, reversing adapter or bellows attachment. Exposure will always be metered with high precision directly through the lens (TTL), making full allowance for angular field and multiplying factors. The three available metering modes optimally cover any lighting situation that might be encountered in practice.

Spot metering

This is ideal for pin-point readings of subjects when shooting against the light or against a very bright or dark background. The 5mm dia. focusing area on the ground-glass screen serves as an aid for aiming. The metering spot covers about 1% of the 6x6cm format and thus guarantees very high metering accuracy. If the detail to be metered is located outside the format centre, use AE lock and reframe as desired.

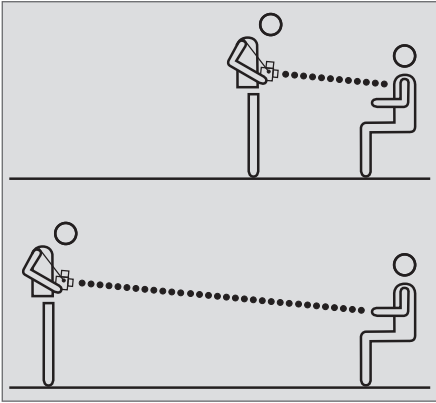

Substitute reading

In critical lighting conditions it is advisable to take a substitute reading, e.g. on a gray card (following the latter's instructions). This will give you a reliable average value for optimal rendition of midtones.

Close-up reading

This is likewise suitable for work in difficult lighting situations: Take a close-up reading of the subject and put the reading in memory. Step back and take the picture from the desired distance.

Lighting contrast

It is a known fact that determining correct exposure becomes all the more difficult, the steeper the film gradation and the higher the lighting contrast within your frame.

Excessive lighting contrast can be reduced by fill flash, softer illumination, changes in shooting direction and viewpoint, different film, compensating development, etc.

If all this is not enough to reduce lighting contrast for the film used, the end use of your pictures will decide over whether lights, shadows or midtones are more important.

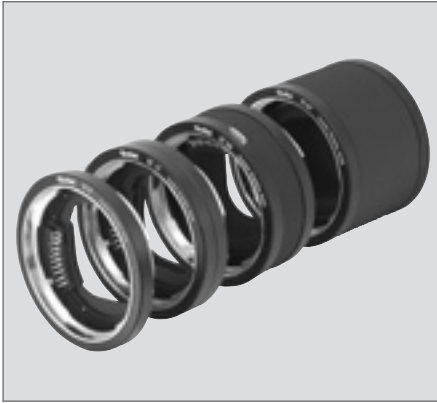

Macro photography

Extension tubes and a bellows attachment take you right up to macro. Extension tubes can be used in any desired combination, even in conjunction with a bellows attachment. The electronic exposure control will remain fully functional.

The following macro accessories are available:

- » **9mm extension tube**
- » **17mm extension tube**
- » **34mm extension tube**
- » **67mm extension tube**
- » **67 – 204mm bellows attachment**
- » **22 – 68mm zoom extension tube**
- » **Reversing adapter**

All extension tubes have a double Rollei bayonet and can thus be combined at will. A combination of the four rigid tubes gives a total extension of 127 mm.

The **bellows attachment** features a precision rack and pinion and a focusing stage. Clamps serve to lock the extension between 67 and 204 mm. The latter can be read off a scale. A 1/4" tripod socket is provided. All exposure and exposure-metering modes of the camera remain fully functional when used in conjunction with the bellows attachment.



The **reversing adapter** further extends the camera's versatility in close-up photography. It allows reverse-mounting of any lens with a size VI filter bayonet. The camera's exposure and exposure-metering modes remain fully functional. It is advisable to combine use of the reversing adapter with that of a bellows attachment. With a reverse-mounted 80mm f/2.8 Xenotar, for example, available magnifications range from 1.8x to 3.5x.

A matte box is a valuable aid for this kind of work which usually involves relatively complex illumination.

X Note

For reasons of physics, the functionality of the AF sensor for both autofocus and use of the focus indicator is limited to an effective minimum aperture of f/5.6. The use of tele-converters or certain close-up accessories may result in a smaller than the nominal f/5.6 aperture.



The **zoom extension** tube with its precise helical focusing mount has an extension of 22 – 68 mm. It greatly facilitates close-up work without gaps or exchange of components, can be combined with a reversing adapter and is suitable for all lenses with size VI filter bayonet.

Taking care of your camera

Your Rolleiflex Hy6 deserves the same care as any precision instrument expected to give reliable service for many years to come. Here are a few useful tips:

- » NEVER touch the reflex mirror or the surfaces of focusing screens with your bare fingers! Use a blower lens brush to remove dust.
- » DO NOT exert pressure on the auxiliary shutter of the camera!
- » When necessary, clean outer lens surfaces: Breathe on them and clean with lens tissue. Antistatic protection: Breathe on the surface and let the moisture evaporate.
- » Protect your camera against the long-term effects of noxious vapors and humidity.

- » Store your camera in a cool and dry place. In humid climate, the camera should be stored in an air-tight enclosure in the presence of a desiccant. High humidity in tropical and subtropical areas is liable to cause corrosion of metal components and fungus growth on glass surfaces.
- » Take special care to protect your camera against any kind of dust.

The Service Department of Franke & Heidecke GmbH will be glad to service your camera and provide help and advice on the subject of photography with Rolleiflex cameras.

Service:

Phone: ++49 531 6800-425 or -282

Fax:

++49 513 6800-244

Address:

Franke & Heidecke GmbH
Feinmechanik und Optik
- Werksservice -
Salzdahlumer Straße 196
D-38126 Braunschweig/Germany



Various accessories

The Rolleiflex Hy6 System includes a number of valuable additional dedicated accessories that considerably extend the uses of the camera, optimize handling and are essential for certain kinds of special work.

The complete camera system with all its accessories is shown on pages 74 – 77.

Interchangeable lenses

The lenses work on the Direct-Drive technology developed by Rollei. Two integral linear motors – controlled by the camera's microcomputer – allow practically instant high-precision aperture and shutter-speed setting from 1/1000 s to 30 s. The interface between camera and lens is a ten-pin contact strip – immobile, free from wear and hermetically sealed.

Our current line of lenses together with the super-fast interchangeable lenses by Schneider-Kreuznach has been specially designed for the professional user.

VARIOUS ACCESSORIES



Tele-converters

There are two tele-converters with extension factors of 1.4x and 2x that may be used in the focus-indicator mode with Rollei lenses.

Interchangeable type 6060*/4560 magazines

These allow size 120 and 220 roll film for 6x6cm and 4.5x6cm to be used in both vertical and horizontal format. All roll-film magazines feature integral motor drive, rapid-loading film inserts, automatic frame counters and laminar drawslides.

Interchangeable view-finders

Interchangeable view-finders and various High-D focusing screens ensure optimal viewing in any kind of work.

The **standard Collapsible Finderhood** is designed for vertical viewing of the view-finder image. It comes with an interchangeable focusing magnifier (+2.5 – -4.5 dpt, 3x magnification).

* in preparation

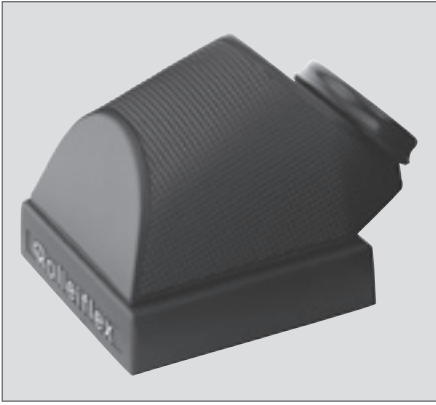

The 45° **Prism-finder** gives an upright, right-side-up view-finder image magnified 2.5x and can be used in four different positions spaced 90° apart so that it makes for comfortable viewing even in awkward shooting positions. As the viewfinder is mounted, its display is automatically adjusted for laterally correct presentation.



The 90° **High-Eyepoint View-finder** gives an upright, right-side-up view-finder image magnified 3.4x. Its eyepiece can be easily adjusted from +4 to -4 diopters. Its display is automatically switched to laterally correct presentation. The High-Eyepoint View-finder can likewise be used in four different positions spaced 90° apart.

VARIOUS ACCESSORIES

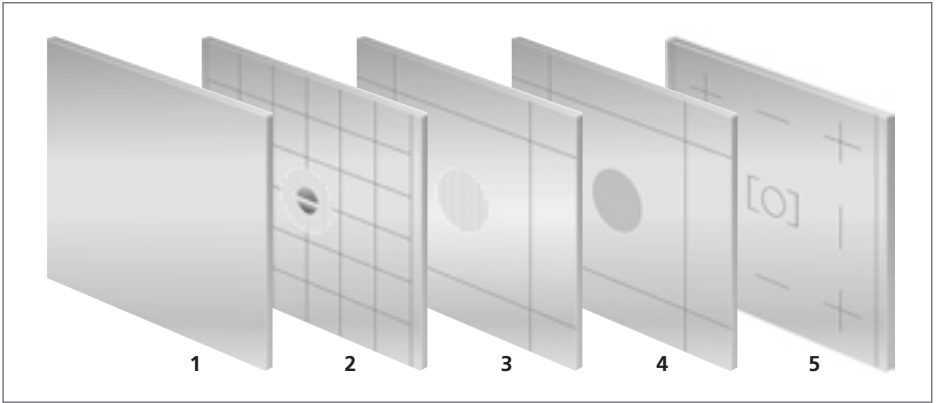

Focusing screens

1 Matte focusing glass screen for precise focusing, especially in macro photography, or for creative work where focusing aids might be found disturbing.

2 Bright focusing screen with central microprism spot and split-image rangefinder for optimum focusing accuracy with vertical lines. Microprism criterion: flicker-free image. Micro-fine ground glass for precise focusing over the entire frame and grid area.

3 Micro-fine bright focusing screen for focusing over the entire frame area and undisturbed, creative framing. Also suitable for use with lenses of small effective aperture as well as depth-of-field preview. With orientation aids for horizontal and vertical limits of 4.5x6cm format.

4 Bright microprism screen for rapid microprism and ground-glass shots. Permits precise focusing even in poor lighting conditions. Focusing criterion: flicker-free image.

5 AF High-D screen – ultra-bright focusing screen showing AF focusing area for optimum assessment of depth of field. Brilliant viewfinder image even in poor light. Frame outlines for vertical and horizontal 4.5x6cm format. Standard focusing screen of Rolleiflex Hy6.

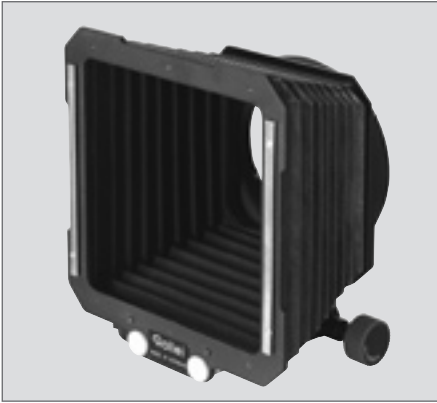

Matte box

The matte box is designed to shield the lens from extraneous sidelight. It is practically an extensible bellows. Its extension scale is marked for focal lengths of 50 mm, 80 mm and 120 – 250 mm. It comes with masks for focal lengths of 120 and 250 mm. Its rear drawer accepts size 75x75mm gelatine filters.

Rolleiflex 6000/Hy6 System

- | | | | |
|-------|--|-------|--|
| 10740 | X-Act ₂ Monorail camera | 59426 | Apo-Tele-Xenar 300 mm f/4 HFT PQ |
| 25857 | Zoom extension tube 22 – 68 mm | 59439 | Super-Angulon 40 mm f/3.5 HFT PQ |
| 54001 | AF-Xenotar 80 mm f/2.8 HFT PQS | 59602 | Sonnar 150 mm f/4 HFT PQS |
| 54080 | AF-Super-Angulon 50 mm f/2.8 HFT | 59926 | M39/40 Behind-the-lens shutter |
| 54120 | AF-Tele-Xenar 150 mm f/4 HFT PQS | 60472 | Lens hood for 40 mm f/3.5 |
| 54300 | AF-Flektogon 35 mm f/3.5 HFT PQS ¹ | 62069 | Extension tube 67 mm |
| 54501 | AF-Variogon 60 – 140 mm f/4.6 PQS | 62624 | Sonnar 250 mm f/5.6 HFT PQS |
| 54701 | AF-Tele-Xenar 180 mm f/2.8 HFT PQ | 63348 | Apo-Symmar 90 mm f/4 HFT PQS |
| 56701 | 1.4x AF-tele-converter HFT | 63350 | Xenotar 80 mm f/2.8 HFT PQS |
| 56704 | AF-High D-Screen | 64866 | F-Distagon 30 mm f/3.5 HFT PQ |
| 58001 | AFD-Xenotar 80 mm f/2.8 HFT PQS | 64872 | LensControl S unit |
| 58080 | AFD-Super-Angulon 50 mm f/2.8 HFT | 64911 | Bright Focusing Screen with
Micro-fine texture |
| 58120 | AFD-Tele-Xenar 150 mm f/4 HFT PQS | 66300 | Makro-Planar 120 mm f/4 HFT PQS |
| 58220 | High eyepoint view-finder 90° ¹ | 86674 | Planar 110 mm f/2 HFT PQ |
| 58242 | Lens hood for 50 mm f/2.8 | 86705 | Distagon 50 mm f/4 FLE HFT PQ |
| 58450 | Battery charger | 86706 | Distagon 50 mm f/4 HFT EL |
| 58502 | AFD-Variogon 60 – 140 mm f/4.6 PQS | 86757 | Sonnar 150 mm f/4 HFT EL |
| 58600 | Rolleiflex Hy6 body | 86760 | Sonnar 250 mm f/5.6 HFT EL |
| 58601 | Rolleiflex Hy6 body complete
with 4560 magazine | 86913 | Variogon 140 – 280 mm HFT PQ |
| 58701 | AFD-Tele-Xenar 180 mm f/2.8 HFT PQ | 96741 | Lens hood extension tube
size VI bayonet for 80 – 250 mm
(except 180 mm) |
| 58715 | Battery 7,2 V 2000 mAh | 96752 | Lens hood extension tube
size VI bayonet for 50 mm f/4
and 60 mm f/3.5 |
| 58722 | Shoulder strap | 96841 | Circular polarising filter, size VI bayonet |
| 58776 | Magazine adapter-frame | 96900 | Zeiss Softlar I, size VI bayonet |
| 58814 | 45° prism-finder | | |
| 58987 | 4560 Magazine | | |

- 96904 Zeiss Softar II, size VI bayonet
- 96950 Gelatine-filter holder, size VI bayonet
- 97054 Ground glass focusing screen
- 97069 Bright focusing screen with central microprism collar and split-image range-finder
- 97074 Bright focusing screen with microprism spot
- 97844 Extension tube 9 mm
- 97868 Extension tube 17 mm
- 97888 Extension tube 34 mm
- 98029 Rapid focusing lever
- 98065 Bellows unit
- 98080 Matte box – professional adjustable lens hood
- 98253 2x tele-converter HFT ²
- 98290 SCA 3562 system flash adapter
- 98410 Reversing adapter
- 98839 Extension tube for 180 mm f/2.8 and 110 mm f/2
- xxxxx Remote release RC 120 ¹
- 98989 Electronic Shutter for View Camera lenses
- 99090 Sliding adapter for digital backs

¹ in preparation

² not working in AF mode

ROLLEIFLEX 6000 / HY6 SYSTEM

>> LENS-ACCESSORIES <<

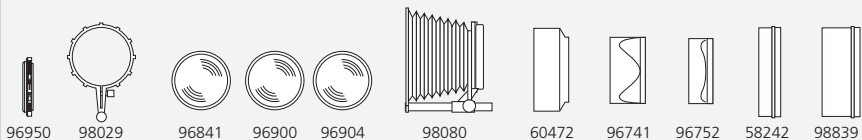

>> MACRO-ACCESSORIES <<

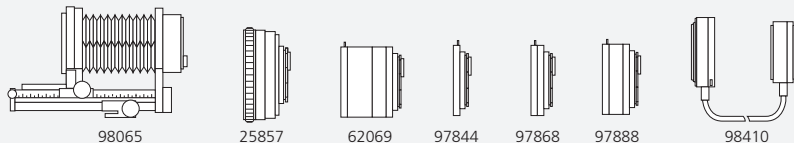

>> INTERCHANGEABLE LENSES AND CONVERTERS <<

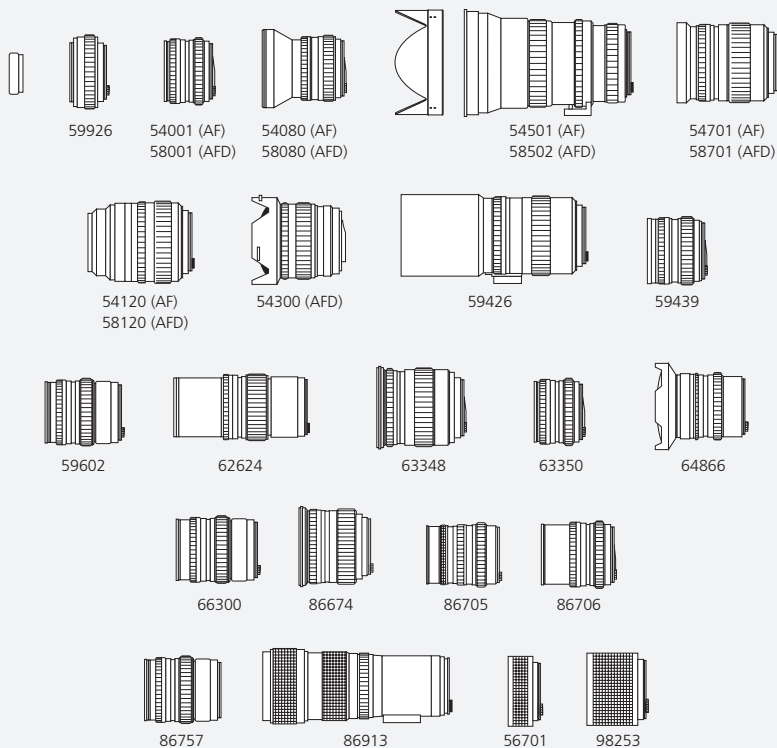

>> X-ACT₂ MONORAIL CAMERA + ACCESSORIES <<

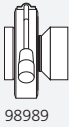

98989

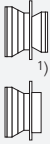

1)

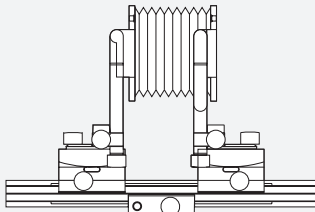

10740



99090



64872

>> VIEWFINDER ACCESSORIES <<

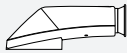

58220



58814



56704



64911



97069



97054



97074

>> CAMERA WITH MAGAZINE AND BACK <<



58600

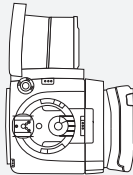

58601



58776



58987



Digital back by
Sinar or Leaf.

>> FLASH ACCESSORIES <<



98290

>> MISCELLANEOUS ACCESSORIES <<

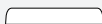

58715

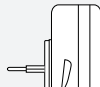

58450

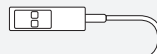

In preparation



58722

TROUBLESHOOTING

Problem

Camera does not work

Camera does not work,
magazine displays 5 LI dE

Film does not wind up to frame 1

----- displayed with PQ lens

Camera does not fire immediately

Focusing screen without view-finder image

View-finder image unsharp at ∞

Shutter does not release

Shutter does not release, but
preceding light metering okay

Battery exhausted prematurely

Camera switches off during film winding or
advance

Camera switches off during serial photography

No fill-in flash with dedicated flash

Cause	Remedy
Camera switched off	Set master switch to <input type="checkbox"/> or <input type="checkbox"/>
No battery or battery exhausted	Insert battery or recharge
Grip of magazine drawslide not pulled down all the way	Pull grip of magazine fully down
Lens not fully locked	Lock lens
Film leader curled or loose	Insert again, if necessary wind leader tightly by hand when inserting
B or T set	Select defined shutter speed
"Self-timer" custom function enabled	Disable self-timer
Mirror locked up	Press shutter release and, if necessary, repeat light metering
Focusing screen improperly positioned or unlocked	Insert screen properly (matted side facing down) and press frame tightly
Magnifier unsuited for user's vision	Use correct magnifier (available from +2.5 to -4.5 dpt)
With focus priority, autofocus (set to "Single") is unable to focus due to difficult contrast situation	Set switch 54 to "M" or "C" or make repeat measurements on the same detail at identical distance
Battery power insufficient; camera switches off	Change or recharge battery
Ambient temperature too low	Keep battery warm, recharge or use spare battery
Film base too stiff, e.g. after storage	Bring film (and camera) to right temperature, use fully charged spare battery
Film inserted improperly	Wind up film uniformly
Insufficient battery power	Use fully charged battery, if possible
Fill-in flash output not preselected	Set output on exposure-compensation switch from -1/3 EV to -3 EV (compensating) or from +1/3 EV to 2 EV (additive)

TROUBLESHOOTING

Problem

Exposure error

Photo incorrectly exposed with preflash metering

Camera does not focus automatically

Camera gives wrong distance settings in AF mode

1 – 2 pictures remain unexposed at the end of film

Cause	Remedy
Lighting conditions changed after mirror lockup	In changing lighting conditions, avoid mirror lock to let camera's auto systems work until shutter trips
Strong extraneous light entering viewing hood (especially with fluorescent tubes)	Swing up view-finder magnifier, avoid direct light incidence, close view-finder hood in difficult lighting conditions; if necessary, use other viewfinder attachment
Warnings on viewfinder or handgrip display went unheeded	Meter the light before every exposure and watch warnings
Strong extraneous light	Avoid direct incident light; close view-finder hood in difficult lighting conditions; if necessary, use other view-finder attachment
Subject too low in contrast Exceeded measuring range	Take substitute reading on more contrasty subject at same distance
Heavy extraneous light	Avoid extraneous light – e.g. close view-finder hood or use other view-finder attachment
Film insufficiently wound up during insertion	Wind up film until arrow mark points to index

X Note

If the camera shows an unusual behavior, first check whether a custom function (such as self-timer) might be activated or if some default settings might have been changed.

LENS TABLE

		Aperture range	Shutter speeds 30 s to	Field angle diagonal/horizontal	Elements/components	Focusing range	Max. diameter	Max. length	Weight	Filter type
F-Distagon 30mm f/3.5 (Fish-Eye)	PQ	3.5 – 22	1/500	180/112°	8 / 7	∞ – 0.3 m	108 mm	122 mm	1550 g	Built-in M 24 x 0.5
AF-Flektogon 35mm f/3.5 (with floating elements)	PQS	3.5 – 22	1/1000	96/76°	10 / 8	∞ – 0.5 m	104 mm	105 mm	1300 g	104 bayonet
Super-Angulon 40mm f/3.5 (with floating elements)	PQ	3.5 – 22	1/500	88/68°	8 / 8	∞ – 0.4 m	83,2 mm	72 mm	750 g	M 77 x 0.75
Distagon 50mm f/4 (with floating elements)	PQ	4 – 32	1/500	75/57°	9 / 8	∞ – 0.5 m	82 mm	95 mm	880 g	Size VI Rolleiflex bayonet
Distagon 50mm f/4	EL	4 – 32	1/500	75/57°	7 / 7	∞ – 0.5 m	81.5 mm	96 mm	840 g	M 67 (inside) VI (outside)
AF-Super-Angulon 50mm f/2.8	PQS	2.8 – 22	1/1000	74/56°	9 / 8	∞ – 0.6 m	104 mm	115 mm	1500 g	M 95 x 1
AFD-Super-Angulon 50mm f/2.8	PQS	2.8 – 22	1/1000	74/56°	9 / 8	∞ – 0.6 m	104 mm	115 mm	1500 g	M 95 x 1
AF-Xenotar 80mm f/2.8	PQS	2.8 – 22	1/1000	52/38°	7 / 6	∞ – 0.8 m	84.5 mm	66.5 mm	520 g	Size VI Rolleiflex bayonet
AFD-Xenotar 80mm f/2.8	PQS	2.8 – 22	1/1000	52/38°	7 / 6	∞ – 0.8 m	84.5 mm	66.5 mm	520 g	Size VI Rolleiflex bayonet
Xenotar 80 f/2.8mm	PQS	2.8 – 22	1/1000	52/38°	7 / 6	∞ – 0.8 m	84.5 mm	66.5 mm	520 g	Size VI Rolleiflex bayonet
Apo-Symmar 90mm f/4 Macro	PQS	4 – 32	1/1000	47/34°	6 / 4	∞ – 0.4 m	104 mm	110 mm	860 g	M 95 x 1
Planar 110mm f/2	PQ	2 – 16	1/500	39/28°	7 / 6	∞ – 0.8 m	104 mm	95 mm	1295 g	M 95 x 1 (filter) 104 bay. (lensh.)
Macro-Planar 120mm f/4	PQS	4 – 32	1/1000	36/26°	6 / 4	∞ – 0.8 m	81.5 mm	102 mm	960 g	Size VI Rolleiflex bayonet

LENS TABLE

		Aperture range	Shutter speeds 30 s to	Field angle diagonal/horizontal	Elements/components	Focusing range	Max. diameter	Max. length	Weight	Filter type
Sonnar 150mm f/4	PQS	4 – 32	1/1000	29/21°	5 / 3	∞ – 1.4 m	81.5 mm	102 mm	890 g	Size VI Rolleiflex bayonet
Sonnar 150mm f/4	EL	4 – 32	1/500	29/21°	5 / 3	∞ – 1.4 m	81.5 mm	102 mm	890 g	M 67 (inside) VI (outside)
AF-Tele-Xenar 150mm f/4	PQS	4 – 22	1/1000	29/21°	5 / 5	∞ – 1.4 m	95 mm	114 mm	890 g	Size VI Rolleiflex bayonet
AFD-Tele-Xenar 150mm f/4	PQS	4 – 22	1/1000	29/21°	5 / 5	∞ – 1.4 m	95 mm	114 mm	890 g	Size VI Rolleiflex bayonet
AF-Tele-Xenar 180mm f/2.8	PQ	2.8 – 22	1/500	26/18°	7 / 7	∞ – 1.8 m	100 mm	135 mm	1480 g	M 95 x 1 (filter) 104 bay. (lensh.)
AFD-Tele-Xenar 180mm f/2.8	PQ	2.8 – 22	1/500	26/18°	7 / 7	∞ – 1.8 m	100 mm	135 mm	1480 g	M 95 x 1 (filter) 104 bay. (lensh.)
Sonnar 250mm f/5.6	PQS	5.6 – 45	1/1000	18/13°	4 / 3	∞ – 2.5 m	82.5 mm	170 mm	1150 g	Size VI Rolleiflex bayonet
Sonnar 250mm f/5.6	EL	5.6 – 45	1/500	18/13°	4 / 3	∞ – 2.5 m	82.5 mm	170 mm	1150 g	M 67 (inside) VI (outside)
Apo-Tele-Xenar 300mm f/4	PQ	4 – 32	1/500	15/11°	6 / 6	∞ – 3.2 m	101 mm	262 mm	2000 g	M 95 x 1
AF-Variogon 60 – 140mm f/4.6	PQS	4.6 – 32	1/1000	67/50° 32/23°	13 / 11	∞ – 0.7 m	119 mm	210 mm	2400 g	Filter adapter M 122 x 1
AFD-Variogon 60 – 140mm f/4.6	PQS	4.6 – 32	1/1000	67/50°	13 / 11	∞ – 0.7 m	119 mm	210 mm	2400 g	Filter adapter M 122 x 1
Variogon 140 – 280mm f/5.6	PQ	5.6 – 45	1/500	32/23° 16/11°	17 / 14	∞ – 2.5 m Macro	94 mm	238 mm	1750 g	M 95 x 1/ 93mm drop-in filters

SPECIFICATIONS

Specifications

Camera type

Single-lens autofocus reflex camera with automatic multi-exposure control, variable metering pattern, TTL autoflash (SCA-3002) and motorized film advance when using magazine 4560.

Autofocus

Cross-type autofocus sensor. Integral red-light grid projector for autofocus in poor light. Non-AF Rolleiflex 6008-compatible PQ/PQS lenses can be used with focus indicator.

Film negative sizes

4,5 x 6 cm and 6 x 6 cm
(6 x 6 cm in preparation)

Film types

Size 120 and 220 roll film for 16 or 32
4.5 x 6cm exposures.

Film speed

ISO 25/15° to 6400/39° can be set on interchangeable magazine in 1/3 increments.

Shutter

Electronically controlled between-the-lens shutter for speeds from 1/1000 s (with PQS lenses) to 32 seconds plus B and T.

Exposure metering

- » Multizone average metering.
- » Centre-weighted multizone metering.
- » Spot metering via central photodiode (approx. 1 % of 6 x 6 film frame).
- » Automatic compensation of extraneous light during metering.
- » Integral RGB sensor for automatic white balance in digital photography.

Exposure functions

- » Shutter-priority AE.
- » Aperture-priority AE.
- » Programmed AE biased for fast shutter speeds.
- » Metered manual in 1/3 increments.

Working ranges

- » Exposure metering EV 0 to EV 19 at ISO 100/21° with 80mm f/2.8 lens
- » Automatic focusing EV 1 to EV 19 at ISO 100/21° with 80mm f/2.8 lens
- » TTL flash ISO 25 – 1600

AE/AF lock

Enabled in all automatic-exposure modes. Locks in EV of shutter speed and aperture.

Exposure compensation

- » Manual setting range from -5 to +5 EV, in 1/3 increments.
- » In bracketing mode in increments of 1/3, 2/3 and 1 EV.

Autoflash

OTF TTL metering.
Automatic flash firing possible with dedicated Metz flash units in case of poor light.
Additive fill-in flash.

Flash synchronization

At all speeds from 1/1000 s to 32 s.
Hot shoe with contacts for dedicated Metz flash units.
SCA interface via Rollei SCA-3562 adapter.

Minimum shutter lag

Ultra-fast shutter response with approx. 3 – 4 ms delay between shutter triggering and exposure, with PQ lenses. With PQS lenses, shutter lag is only approx. 2 s. Additional automatic stand-by mode after shutter release is possible.

Depth-of-field preview

By pressing stop-down button, in any mode.

Mirror lock

In any mode, with AE lock and display.

Lens mount

Rollei bayonet mount. 10-contact signal strip for aperture and shutter-speed transfer. Exposure control fully functional, even with bellows attachment, extension tubes and reversing adapter.

Multiple exposures

Via electronic suppression of film advance, without view-finder control, e.g. for digital printing.

Reflex mirror

Direct-drive reflex mirror with partially transmitting multilayer coating; can be locked up.

Viewfinder system

Standard collapsible finder-hood with swing-up focusing magnifier, interchangeable for 90° High eyepoint finder or 45° prism finder. Focusing screens. Superbright High-D focusing screen is standard equipment.

View-finder information

Illuminated view-finder LCD for focusing status, shutter speed and aperture (in 1/3 increments); metered-manual exposure balancing, exposure compensation, spot metering, flash-indication, custom functions, battery condition.

Control Display on Handgrip

Illuminated Control Display showing Exposure Mode, AE Lock, Autofocus Mode, Aperture, Exposure Compensation, Light Meter, Shutter Speed, Mirror Lock, ISO-Film Speed, Flash Mode and Metering Pattern.

Film advance

Automatic film advance by high-performance motor incorporated in magazine. Single-frame and continuous shooting with up to 2 fps. Automatic film winding up to frame 1. Automatic film winding after exposure of last frame.

Power supply

By rechargeable high-performance 7.4V, 2200 mAh lithium-ion battery.

Handgrip

With four click stops (for use of folding hood, 45° or 90° finder). Detachable leather wrist strap.

Interchangeable film magazines

Type 4560 4.5 x 6cm film magazine with integral laminar drawslide, frame counter, film-speed setting, film-type indicator and pre-loadable film insert.
Type 6060 film magazine for 6 x 6cm format in preparation.

Custom functions, accessible via menus

- » Leading or trailing sync
- » Self-timer
- » Automatic Exposure bracketing in 1/3 increments optional
- » Focus bracketing
- » Trap function
- » Ultra fast shutter

Interfaces

- » Interface for digital backs from Sinar and Leaf
- » 8-pin screw-type universal connector for electrical cable release and other electronic accessories
- » Mini USB socket, e. g. for Firmware Updates

SPECIFICATIONS

Working temperature

From -20° C to +60° C.

Quick-release tripod plate (Novoflex Q-BASE system)

With 1/4" and 3/8" tripod socket

Suitable digital backs

Sinar back eMotion 22 / 54 / 75

Sinar back eVolution 75 H

Sinar back 54 MC / M

Some digital backs by Leaf

Suitable lenses

Schneider AFD 50, 80, 150, 180,

Zoom 60 – 140 as well as AFD Flektogon 35.

All PQ and PQS lenses that are compatible with Rolleiflex 6008 cameras.

Dimensions (mm/wxhxd)

- » Camera body: 157 x 112 x 78
- » 80mm f/2.8 lens: 67 x 90
- » 4560 film magazine: 88 x 86 x 50
- » Digital back: See manufacturer's data

Weight

- » Camera body with battery: 990 g
- » 80mm f/2.8 lens: 500 g
- » 4560 film magazine: 330 g
- » Digital back: See manufacturer's data

Subject to change without notice.

Intertek ETL SEMKO

AUTHORIZATION TO MARK

This authorizes the application of the Certification Marks shown below to the models described in the Product(s) Covered section when made in accordance with the conditions set forth in the Certification Agreement and Listing Report. This authorization also applies to multiple listee model(s) identified on the correlation page of the Listing Report.

Applicant: HAHNEL INDUSTRIES LTD.
Parnell Street, Bandon, Co. Cork, Ireland

Contact: Name: Mr. Michael Hahnel Phone: 353-0-23-41600

Manufacturer:

Party Authorized To Apply Mark: (Same as Manufacturer)

Report Issuing Office: Intertek Testing Services Taiwan Ltd.

Report No.: C705271

Product Covered: Ultima Charger, Models 90800 (trade name: HAHNEL INDUSTRIES LTD.) and M50800

Description: The product covered by this Report is an ULTIMA CHARGER for information technology equipment battery and indoor use only. It is considered as direct plug-in and Class II equipment.

Standard(s): Information Technology Equipment – Safety – Part 1: General Requirements (ANSI/UL 60950-1: 2003 and CAN/CSA-C22.2 No. 60950-1-03, First Edition, Rev. November 26, 2003)

This document is the property of Intertek Testing Services and is not transferable. Only the Applicant may reproduce this document. The certification mark(s) may be applied only at the above noted location of the Party Authorized to Apply Mark.

Authorized by: 
William T. Starr
Certification Manager



Date: 23 Aug 2016

Control Number: 3102371

This document supersedes all previous Authorizations to Mark for the noted Report number.

Intertek Testing Services NA Inc.
185 Main Street, Cortland, NY 13045, USA
Telephone 800-345-3851 or 607-753-0711 Fax 607-756-0899



Registered EU-Design No.: 000586417-0001



Franke & Heidecke GmbH · Feinmechanik und Optik
Salzdahlumer Strasse 196 · D-38126 Braunschweig
www.franke-heidecke.net · Germany