

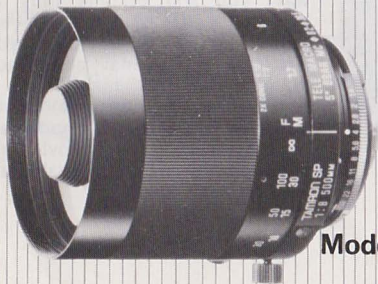

Model 06B



Model 55B

TAMRON-SP

350mm F/5.6

500mm F/8

CF TELE MACRO CATADIOPTRIC LENS

OWNER'S MANUAL



ADAPTALL-2 MOUNT SYSTEM



Welcome to the ever-expanding world of Tamron

Thank you for selecting the Tamron SP catadioptric lens. Before using your new Tamron lens, take a few minutes and carefully read this instruction manual. This way, you will become fully acquainted with the features and proper method of operating your lens in the normal and macro modes. This will enable you to obtain the best possible results. With proper handling and care, your Tamron lens will provide you with many years of enjoyable and trouble-free operation.

1. DESCRIPTION OF PARTS AND SPECIFICATIONS

Focusing ring

Macro magnification scale (w/2X tele-converter)

Macro magnification scale

Distance scale

Distance scale index

Mount index for all Nikon cameras, Nikkomat FT3 and other cameras



Model 06B

Focal Length:	350mm
Aperture:	F/5.6
Construction:	7 elements in 4 groups
Angle of View:	7°30'
Coating:	BBAR multi-layer coating
Lens Accessory Size:	30.5mm rear, screw-in (82mm front)
Minimum Focus from Film Plane:	1.1m (43.3 in.)
Maximum Magnification () w/2X tele-converter:	1 : 2.5 (1 : 1.25)
Focusing Ring Rotation:	—
Length (at infinity):	74.5mm (2.9 in.)
Diameter:	86mm (3.4 in.)
Weight:	535 g (18.9 oz.)
Lens Hood:	Detachable, screw-in
Filter:	A rear normal filter is supplied with your lens.
Optional Accessories:	Rear filter set available consisting of ND4X, Y52, O56, and R60. ND2X and 81B also available separately. Flat-field 2X tele-converter, tele-view adaptor, 82mm "Normal" filter.

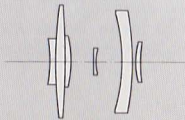

Focusing ring

Macro magnification scale (w/2X tele-converter)

Macro magnification scale

Distance scale

Tripod mounting ring fastening screw

Distance scale index

Mounting index (in red) for Nikkomat FT, FTN, EL and FLW

Mount index for all Nikon cameras, Nikkomat FT3 and other cameras

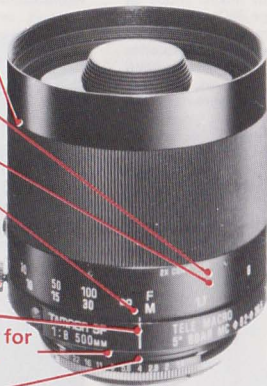

Model 55B

Focal Length:	500 mm
Aperture:	F/8
Construction:	7 elements in 4 groups
Angle of View:	5°
Coating:	BBAR multi-layer coating
Lens Accessory Size:	30.5mm rear, screw-in (82mm front)
Minimum Focus from Film Plane:	1.7 m (66.9 in)
Maximum Magnification () w/2X tele-converter:	1 : 3 (1 : 1.5)
Focusing Ring Rotation:	—
Length (at infinity):	87 mm (3.4 in)
Diameter:	84 mm (3.3 in)
Weight:	576 g (20.2 ounce)
Lens Hood:	Detachable, screw-in
Filter:	A rear normal filter is supplied with your lens.
Optional Accessories:	Rear filter set available consisting of ND4X, Y52, O56, and R60. ND2X and 81B also available separately. Flat-field 2X tele-converter, tele-view adaptor, 82mm "Normal" filter.

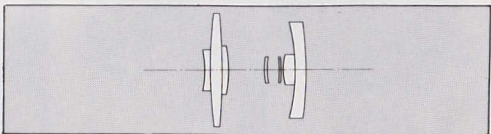

2. PRINCIPAL FEATURES

(1) Continuous Focusing – CF

Continuous focusing from infinity to the minimum object distance of 1.1 meters (for 350mm F5.6) or 1.7 meters (for 500mm F8) is permitted. The maximum macro magnification ratio at the minimum object distance of 1.1 meters is 1:2.5 (for 350mm F5.6) or 1:3 (for 500mm F8 at the minimum object distance of 1.7 meters).

(2) Tele-Macro Capability

Your new mirror lens features a "tele-macro" capability which permits photographing an object in macro mode as close as 1.1 meters (for 350mm F5.6) or 1.7 meters (for 500mm F8).

The lens has opened up new horizons for macro photography which have been almost impossible in the past; you can photograph objects which were normally

restricted, distance wise, such as insects, timid animals, accessories in a show window, birds in a cage, etc. in macro mode without closely approaching the object.



Subject distance 20 m,
F/8, 1/60 second

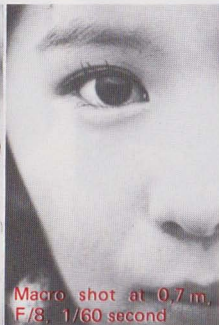

Macro shot at 0,7 m,
F/8, 1/60 second



Subject distance 5 m, F/8, 1/125 sec.



Macro shot at 1,7 m, F/8, 1/125 sec.

(3) Constant F-Number

A conventional fixed focal length lens requires troublesome F/stop calculations depending on the object distance. Tamron's innovative focusing system allows you to maintain a constant light transmission while focusing so that the F-number does not change at any focus settings from infinity to close up (macro). Therefore, you can obtain optimum exposure time without any correction even in auto flash photography, which so far, required obtaining a corrected value by means of guide numbers. In addition, with the tele-macro capability of the Tamron mirror lens permitting the use of an auto flash at the minimum distance of 1.1 meters

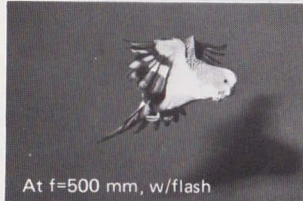

At f=500 mm, w/flash

(for 350mm F5.6) or 1.7 meters, (for 500mm F8), high-speed macro photography utilizing an auto flash is possible.

(4) Silver-Evaporated Reflex Mirrors

In order to increase light transmission efficiency, your new Tamron mirror lens incorporates special silver-evaporated reflex mirrors rather than the conventional mirrors whose surfaces are coated with aluminum. With two reflex mirrors, the total reflection percentage within a lens having aluminum-coated mirrors becomes 60% or less. However, Tamron has succeeded in obtaining a reflection percentage as high as 80% or more with the silver-evaporated reflex mirrors. The special silver evaporation which is applied to the reflex mirrors is extremely durable. The degree of durability ex-

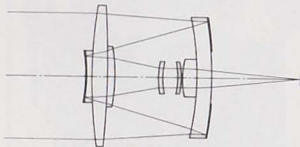

ceeds the requirements contained in the MIL standard by more than three times thanks to Tamron's original coating technique employing a combination of a single layer of metallic coating and two layers of high molecular films.

(5) Unique and Convenient Outer Design

In designing the outer appearance of the lens, emphasis was put on the maximum handling convenience by concentrating all the necessary information in one place where it can be easily read. Most of Tamron lenses, including your new lens, are marked with the maximum macro magnification scale to be applied when Tamron's SP 2X tele-converter is used.



PRINCIPAL FEATURES

(6) Expanded Vistas of Photography By Employing An SP 2X High- Performance Tele-Converter

Tamron's SP 2X tele-converter is a high-performance converter in the Adaptall system. It was specially developed for exclusive use with the telephoto and zoom lenses in the SP and Adaptall-2 series. The combination of the tele-converter and your Tamron mirror lens greatly expands the conventional range of photography as follows:



- The combination of the tele-converter and the lens permits expanding the range of the macro magnification ratio from 1:2.5 to 1:1.25 (for 350mm F5.6) or 1:3 to 1:1.5 (for 500mm F8) which is almost life-size.
- The tele-converter and lens combine to make a very compact 700mm (for 350mm) or 1000mm (500mm) ultra telephoto that is convenient to carry around.

(7) Adaptall Custom Mount System

Via Tamron's exclusive Adaptall custom mount system, your new lens can be used with virtually any popular single lens reflex camera.

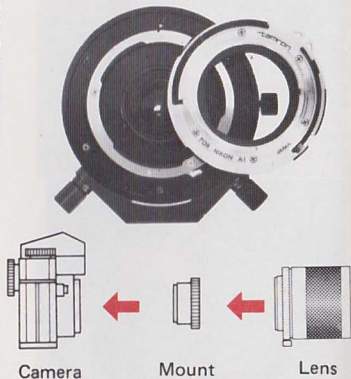

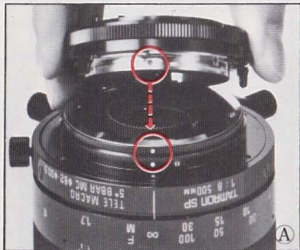

3. INSTALLING AND REMOVING THE TAMRON ADAPTALL CUSTOM MOUNT

1. Align the green dot on the custom mount with the matching green dot on the lens barrel and turn the mount clockwise until the mount is locked (clicks) into the proper position.



2. Move the meter coupling lever  provided on the custom mount so that it engages in the slot provided on the lens and now the aperture of the lens will couple to the exposure control mechanism of your camera. The method of installing custom



mounts for Canon FD, Minolta and Nikon is the same as described in Steps 1 and 2, however, the custom mount for Canon FD, Minolta and Nikon have two coupling levers . Therefore, when the mount is installed, engage the two coupling levers in the corresponding slots  on both sides of the lens.

Note 1. When Fitting The Custom Mount For Nikon with 500mm Mirror Lens.

A) With All Nikon Cameras and The Nikkormat FT3:

For use with Nikon cameras and the Nikkormat FT3 (and also all other brand SLRs) the rear ring of the SP500mm is set during manufacture with the two green dots aligned together. Therefore with the above cameras be sure to use the lens in this position. With AI system cameras push the exposure meter coupling lever on the camera upwards to prevent the lens from cross-coupling to the meter. This allows the lens to be used in the stop-down metering mode in the same manner as a Nikon lens. (Picture © on next page.)

INSTALLING AND REMOVING THE TAMRON ADAPTALL CUSTOM MOUNT

- B) With Nikkormat FT, FTN, EL and ELW:

As explained on the label affixed on the rear cap of the lens, slacken the red screw on the rear ring with the screwdriver supplied, and turn the ring clockwise all the way until it stops. Then retighten the screw. This allows the lens to be used in the stop-down metering mode in the same manner as a Nikon lens. (Picture D)

Note 2. When Fitting The Custom Mount For Nikon with 350mm Mirror Lens:

- A) With Nikon Photomic and Nikon Photomic S:

Slacken the red screw on the rear ring with the screwdriver supplied and use the lens at this position.

- B) For all other Nikon and Nikkormat cameras, use the lens as it is. (No adjustment is necessary)

3. Your Tamron lens which is now fitted with an Adaptall custom mount can be secured to your camera in the same manner as the camera manufacturer's lenses.

4. Removing the Custom Mount:

An L-shaped mount release lever is provided directly opposite the aperture indicator window which, when depressed, releases the mount. Therefore, while keeping the L-shaped mount release lever depressed, turn the custom mount counterclockwise until it stops and then lift the mount off the lens.



4. OPERATING INSTRUCTIONS

(1) Correct Method of Handling a Long Telephoto Lens and Using It with a Tripod.

Compared with telephoto lenses normally used (i.e. 135 to 300mm), the angle of view of your lens is considerably narrower, which can possibly cause "camera shake" problems when the shutter is released. Therefore, taking this into consideration, follow the recommendations as described below when you use the lens.

a. Hand-Held Photography

Hold the focusing ring of the lens with your left hand. Draw the camera near and hold it firmly against your face with left hand. If you wear glasses, fix the viewfinder frame securely against the glasses. The slowest shutter speed which permits hand-held shots is normally considered to be $1/\text{focal length}$ of the lens. Therefore, with your lens, it is recommended that you use a shutter speed of $1/500$ second or faster, however, depending upon the extent of your profi-

ciency in hand-held photography with a long telephoto lens, shutter speeds slower than $1/500$ second may also be used.



b. With Tripod:

It is recommended to use heavy duty tripod when using a long telephoto lens. Also use cable release for shutter releasing.

(2) Focusing

a. While looking through your camera's viewfinder, turn the focusing ring until you see a sharp image. If your camera accepts different focusing screens, then it is advisable to use a matte-fresnel screen. This type of screen is normally recommended for ultra-telephoto lenses and it will make focusing easier.

Note: Since your mirror lens is an ultra-telephoto lens, the position of the distance scale index and infinity mark are

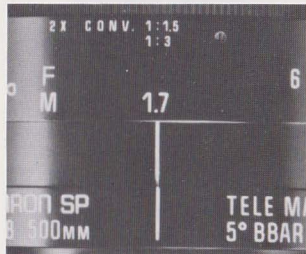

OPERATING INSTRUCTIONS

moved slightly to the positive side. (In case of SP 350mm lens, this position is marked with L-shaped mark on the distance scale).

b. Focusing In Macro Mode

The depth-of-field becomes extremely shallow when you use an ultra-telephoto lens in the macro mode. You should first practice focusing prior to photographing any subjects and you may also want to take a test roll of film. If your camera accepts interchangeable screens you should use a cross-screen and in addition, a viewing magnifier would greatly assist you.



(3) Macro Operation

The Tamron mirror lens has a new feature which permits continuous focusing from infinity to macro and no additional special operation is required for macro use. On the focusing ring, the macro magnification ratios are shown in orange. In addition, the magnification ratios for use with the SP 2X tele-converter (which doubles the focal length of the lens) are engraved in yellow. Simply set the lens at the desired macro magnification scale and then focus the lens.



**Note for custom mounts which have an aperture scale
(Note for 500mm lens)**

Some custom mounts such as Nikon AI and Minolta MD have an aperture scale which is visible in cameras which have this facility. When fitting the custom mount simply align the green dot on the mount with the matching green dot on the lens barrel as described in the owner's manual. Please note that as the SP 500mm lens has a fixed aperture of F/8 this value is transmitted to the camera irrespective of the fact that the aperture display on the mount shows F/4. Similarly, when the 01F flat field 2X teleconverter is used the effective aperture value of F/16 is transmitted to the camera although the aperture display on the mount again shows F/4, and F/8 is indicated on the body of the teleconverter itself. As mentioned the above has no effect in actual picture taking as the correct exposure value is always transmitted to the camera.

(4) Lens Hood

A lens hood is supplied with the Tamron lens. The lens hood prevents unnecessary light from striking the lens and causing unwanted glare. The lens hood supplied is detachable, screw-in type hood employing a very convenient system.

- a. To attach the hood, rotate it in the clockwise direction onto the thread provided on the front end of the lens.
- b. When the lens is not in use, detach the hood from the lens, reverse it and put it on the lens barrel.

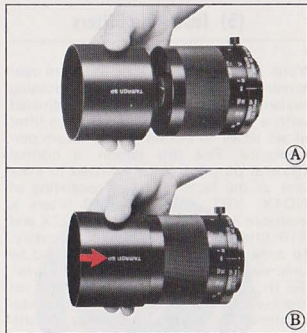

OPERATING INSTRUCTIONS

(5) Installing Filters

Your mirror lens accepts 30.5mm rear screw-in filters. Since the focusing system of the lens is precisely adjusted with a filter fitted, you must use a filter at all times to obtain the optimum performance. For this reason, a normal (general purpose) filter is fitted to your lens at the factory. A set consisting of ND4X, Y52, O56 and R60 filters is available as an optional extra. ND2X and 81B filters are also available separately. In order to remove a filter it should be unscrewed by turning it anticlockwise. To fit another filter simply screw it on clockwise making sure it is not over-tightened as otherwise it may be difficult to remove. When you wish to replace filters, it is easier if the custom mount is removed from the lens. It is best to use filters which have been precision engineered for ultra tele photo lenses and hence this is the reason the above mentioned filters are available. You should always hold the filter by its rim and not by the glass surface because finger prints, etc. can damage

the quality of your pictures and possibly damage the filter coating.



(6) Mounting and Removing The Tripod Ring

(1) For 500mm lens

The tripod ring can be mounted or removed as shown in photo (A) by tightening or loosening the two tripod ring mounting screws. In addition, by loosening the tripod fastening screw provided on one side of the ring, you can select any position within 360°, thus commanding free camera movement, horizontally or vertically. When you are mounting your camera and lens on a tripod, you should always use the tripod mounting ring and not the tripod socket on your camera because the tripod ring will provide you with maximum stability and convenience.

Note: The tripod mounting ring should be fitted with the fastening screw near to the back of the lens as otherwise the ring may foul the camera body.

When mounting the lens on a tripod, do not tighten the fastening screw of the tripod's universal head excessively—as otherwise the fastening screw may come

into contact with the focusing ring of the lens (see Fig. 1). (If it touches the lens, the focusing ring will become inoperable.)

(2) For 350mm lens

The tripod mounting base is built-in on the SP 350mm lens. The base can be rotated in 90 degrees; push the L-shaped lever at the rear end of the lens barrel and turn the lens until the lever clicks.

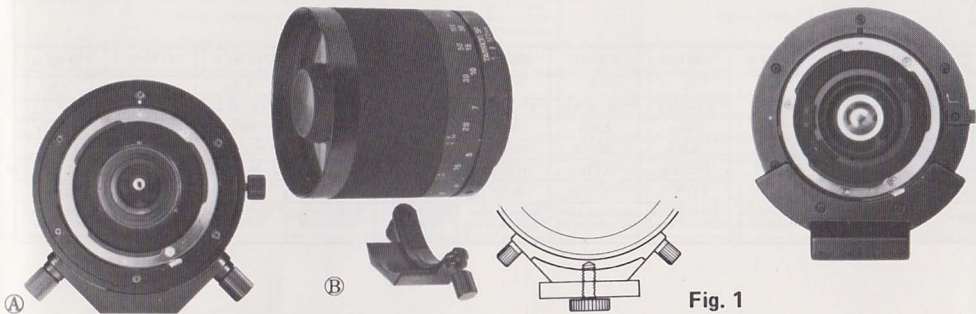

Fig. 1

5. SPECIFICATIONS OF TAMRON LENSES

Model No.	51B	01B	02B	52B	03B	04B	54B	06B	55B
Specifications									
Focal Length	17mm	24mm	28mm	90mm	135mm	200mm	300mm	350mm	500mm
Aperture	F/3.5	F/2.5	F/2.5	F/2.5	F/2.5	F/3.5	F/5.6	F/5.6	F/8
Angle of View (degrees)	104	84	75	27	18	12°	8	7.3	5
Lens Construction (Groups/Elements)	10/12	9/10	7/7	6/8	4/4	5/5	5/6	4/7	4/7
Coating	BBAR multiple layer coating								
Minimum Focus from Film Plane m (in.)	0.25 (9.8)	0.25 (9.8)	0.25 (9.8)	0.39 (15.3)	1.2 (47.2)	1.7 (66.9)	1.4 (55.1)	1.1 (43.3)	1.7 (66.9)
Maximum Magnification Ratio	—	—	—	1:2		1:5.9	1:3.3	1:2.5	1:3
Aperture Range	3.5—22 AE	2.5—22AE	2.5—32 AE	2.5—32 AE	2.5—32 AE	3.5—32 AE	5.6—32 AE	—	—
Filter Size	—	55mm	49mm	49mm	58mm	58mm	58mm	30.5mm	30.5mm
Length mm (in.)	43 (1.7)	38 (1.5)	33 (1.3)	66 (2.6)	79.5 (3.1)	108 (4.3)	163.5 (6.4)	74.5 (2.9)	87 (3.4)
Diameter mm (in.)	70 (2.8)	64.5 (2.5)	64.5 (2.5)	64.5 (2.5)	64.5 (2.5)	68.5 (2.7)	64.5 (2.5)	86 (3.4)	84 (3.3)
Weight gram (oz.)	270 (9.5)	230 (8.1)	180 (6.3)	420 (14.8)	410 (14.5)	540 (19.0)	610 (21.5)	577 (20.4)	575 (20.3)
Lens Hood	Push-on type (optional extra)	Screw-in type (optional extra)	Screw-in type (optional extra)	Screw-in type (optional extra)	Built-in type, retractable	Built-in type, retractable	Built-in type, retractable	Screw-in type, detachable	Screw-in, type detachable

13A	07A	09A	01A	20A	52A	103A	104A	05A	06A	01F
24-48mm	28-50mm	35-70mm	35-80mm	70-150mm	70-210mm	80-210mm	75-250mm	70-350mm	200-500mm	2X the focal length of original lens
F/3.5-3.8	F/3.5-4.5	F/3.5-4.5	F/2.8-3.8	F/3.5	F/3.5-4	F/3.8-4	F/3.8-4.5	F/4.5	F/6.9	-
84-48.5	75-47	64-34	64-30	34-16	34-11	30-11.3	32-10	34-7	12-5	-
9/10	9/9	7/7	8/9	10/13	15/16	10/13	10/13	13/15	8/14	5/6
BBAR multiple layer coating					BBAR and green multiple layer coating	BBAR multiple layer coating				
0.6 (23.6)	0.25 (9.8)	0.25 (9.8)	0.27 (10.6)	0.7 (27.5)	0.75 (29.5)	0.9 (35.4)	1.2 (47.2)	2.5 (98.4)	3.0 (118)	-
-	1:4	1:2.8	1:2.5	1:3	1:2	1:2.8	1:3.4	-	-	-
3.5/3.8-32 AE	3.5/4.5-32 AE	3.5/4.5-32 AE	2.8/3.8-32AE	3.5-32 AE	3.5/4-32 AE	3.8/4-32 AE	3.8/4.5-32 AE	4.5-32 AE	6.9-32	-
77mm(on hood)	58mm	58mm	62mm	49mm	58mm	58mm	62mm	82mm	82mm	-
61 (2.4)	46.2 (1.8)	56.5 (2.2)	72 (2.8)	99 (3.9)	165 (6.5)	142 (5.6)	176.5 (7.0)	274 (10.8)	370 (14.6)	42.5 (1.7)
64.5 (2.5)	64.7 (2.5)	64.5 (2.5)	64.5 (2.5)	64.5 (2.5)	64.5 (2.5)	65 (2.5)	71 (2.8)	90 (3.5)	90 (3.5)	64.5 (2.5)
346 (12.2)	297 (10.5)	322 (11.4)	386 (13.6)	459 (16.2)	750 (26.5)	634(22.4)	856 (30.2)	2170 (76.5)	2770(97.7)	250 (8.8)
Bayonet type (optional extra)	Push-on type (optional extra)	Push-on type (optional extra)	Push-on type (optional extra)	Built-in type, retractable	Built-in type, retractable	Screw-in type	Built-in type, retractable	Built-in type, retractable	Built-in type, retractable	-

5. SPECIFICATIONS OF TAMRON LENSES

Model No.	51B	01B	02B	52B	03B	04B	54B	06B	55B
Focal Length	17mm	24mm	28mm	90mm	135mm	200mm	300mm	350mm	500mm
Aperture	F/3.5	F/2.5	F/2.5	F/2.5	F/2.5	F/3.5	F/5.6	F/5.6	F/8
Angle of View (degrees)	104	84	75	27	18	12°	8	7.3	5
Lens Construction (Groups/Elements)	10/12	9/10	7/7	6/8	4/4	5/5	5/6	4/7	4/7
Coating	BBAR multiple layer coating								
Minimum Focus from Film Plane m (in.)	0.25 (9.8)	0.25 (9.8)	0.25 (9.8)	0.39 (15.3)	1.2 (47.2)	1.7 (66.9)	1.4 (55.1)	1.1 (43.3)	1.7 (66.9)
Maximum Magnification Ratio	—	—	—	1:2	—	1:5.9	1:3.3	1:2.5	1:3
Aperture Range	3.5–22 AE	2.5–22AE	2.5–32 AE	2.5–32 AE	2.5–32 AE	3.5–32 AE	5.6–32 AE	—	—
Filter Size	—	55mm	49mm	49mm	58mm	58mm	58mm	30.5mm	30.5mm
Length mm (in.)	43 (1.7)	38 (1.5)	33 (1.3)	66 (2.6)	79.5 (3.1)	108 (4.3)	163.5 (6.4)	74.5 (2.9)	87 (3.4)
Diameter mm (in.)	70 (2.8)	64.5 (2.5)	64.5 (2.5)	64.5 (2.5)	64.5 (2.5)	68.5 (2.7)	64.5 (2.5)	86 (3.4)	84 (3.3)
Weight gram (oz.)	270 (9.5)	230 (8.1)	180 (6.3)	420 (14.8)	410 (14.5)	540 (19.0)	610 (21.5)	577 (20.4)	575 (20.3)
Lens Hood	Push-on type (optional extra)	Screw-in type (optional extra)	Screw-in type (optional extra)	Screw-in type (optional extra)	Built-in type, retractable	Built-in type, retractable	Built-in type, retractable	Screw-in type, detachable	Screw-in, type detachable

13A	07A	09A	01A	20A	52A	103A	104A	05A	06A	01F
24–48mm	28–50mm	35–70mm	35–80mm	70–150mm	70–210mm	80–210mm	75–250mm	70–350mm	200–500mm	2X the focal length of original lens
F/3.5–3.8	F/3.5–4.5	F/3.5–4.5	F/2.8–3.8	F/3.5	F/3.5–4	F/3.8–4	F/3.8–4.5	F/4.5	F/6.9	—
84–48.5	75–47	64–34	64–30	34–16	34–11	30–11.3	32–10	34–7	12–5	—
9/10	9/9	7/7	8/9	10/13	15/16	10/13	10/13	13/15	8/14	5/6
BBAR multiple layer coating					BBAR and green multiple layer coating	BBAR multiple layer coating				
0.6 (23.6)	0.25 (9.8)	0.25 (9.8)	0.27 (10.6)	0.7 (27.5)	0.75 (29.5)	0.9 (35.4)	1.2 (47.2)	2.5 (98.4)	3.0 (118)	—
—	1:4	1:2.8	1:2.5	1:3	1:2	1:2.8	1:3.4	—	—	—
3.5/3.8–32 AE	3.5/4.5–32 AE	3.5/4.5–32 AE	2.8/3.8–32AE	3.5–32 AE	3.5/4–32 AE	3.8/4–32 AE	3.8/4.5–32 AE	4.5–32 AE	6.9–32	—
77mm(on hood)	58mm	58mm	62mm	49mm	58mm	58mm	62mm	82mm	82mm	—
61 (2.4)	46.2 (1.8)	56.5 (2.2)	72 (2.8)	99 (3.9)	165 (6.5)	142 (5.6)	176.5 (7.0)	274 (10.8)	370 (14.6)	42.5 (1.7)
64.5 (2.5)	64.7 (2.5)	64.5 (2.5)	64.5 (2.5)	64.5 (2.5)	64.5 (2.5)	65 (2.5)	71 (2.8)	90 (3.5)	90 (3.5)	64.5 (2.5)
346 (12.2)	297 (10.5)	322 (11.4)	386 (13.6)	459 (16.2)	750 (26.5)	634(22.4)	856 (30.2)	2170 (76.5)	2770(97.7)	250 (8.8)
Bayonet type (optional extra)	Push-on type (optional extra)	Push-on type (optional extra)	Push-on type (optional extra)	Built-in type, retractable	Built-in type, retractable	Screw-in type	Built-in type, retractable	Built-in type, retractable	Built-in type, retractable	—

6. TAMRON ADAPTALL/ADAPTALL-2 MOUNT SYSTEM

Adaptall Mounts	Adaptall Lenses	SP/Adaptall-2 Lenses
For Pentax K	Yes	Yes
For Pentax ES ◊	Yes	Yes ◊
For Pentax Universal	Yes	Yes
For Nikon A1 †	Yes	Yes †
For Fujica ST	Yes	Yes
For Mamiya SX	Yes	Yes
For Topcon RE ◊	Yes	Yes ◊
For Rollei/Voigtlander	Yes	Yes
For Canon FL	Yes	Yes
For Minolta	Yes	Yes
For Olympus OM	Yes	(●)
For Contax/Yashica*	Yes	Yes*
For Canon FD (6 mounts) ▼ f/2.5, f/2.8, f/3.5, f/3.8, f/4.5, f/5.6	Yes	—
For Konica AR (6 mounts) ▼ f/2.5, f/2.8, f/3.5, f/3.8, f/4.5, f/5.6	Yes	—
For Minolta MD (4 mounts) f/2.5/4.5, f/2.8/5.6, f/3.5, f/3.8.	Yes	—
SP/Adaptall-2 Mounts	Adaptall Lenses	SP/Adaptall-2 Lenses
For Olympus OM	Yes	Yes
For Canon FD	—	Yes
For Minolta MD	—	Yes
For Konica AR*	—	Yes*
For Contax-Yashica	—	Yes
For "C" mount for CCTV/VTR cameras and 16mm movie cameras	Yes	Yes
For "MS" mount for CCTV/VTR cameras	Yes	Yes

◊ Due to small rear aperture, this mount will not accept the SP 70—210mm f/3.5—4, SP 90mm f/2.5, SP Flat Field 2X Converter, and Adaptall-2 80—210mm f/3.8—4.

† Some early Nikon A1 Adaptall mounts cannot be used with the above lenses. Please check with your dealer.

• Mount requires initial maximum aperture adjustment.

(●) Does not have aperture stop down control on mounts. SP lenses do not have Auto/Manual selector switch.

▼ Will not accept the SP Flat Field 2X Converter, due to its small inside diameter.

Note: The Tamron SP Flat Field Tele-Converter is compatible with most Tamron Interchangeable Lenses, except wide angle lenses. However, be sure to use the appropriate mount.

7. CARING FOR YOUR LENS

1. Avoid touching the surface of your lens. When not using your lens, be sure to put the lens cap on for protection.



2. Cleaning your lens:

- a. Use a photographic lens brush to remove dust or dirt from the surface.
- b. Moisten a lens cleaning tissue with one drop of cleaning solution and clean the surface gently.
- c. Remove excess moisture from the lens surface with a dry tissue.

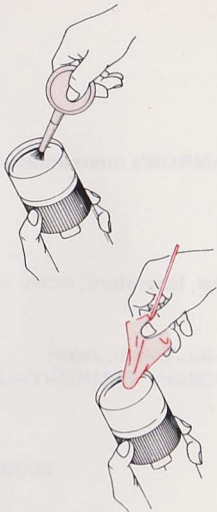

3. When carrying a zoom lens mounted on your camera, hang it from your shoulder with the lens towards your body to protect it from objects that it might hit.



4. Fine photographic equipment can be delicate. Protect it from any avoidable impact.

5. Always store your lens in a cool, dry place. During humid or wet weather it is an especially good idea to store it with the silica gel packet that was supplied with your lens.



TAMRON International Service

Should any TAMRON product require service, TAMRON's international service is available in over 48 nations worldwide.

TAMRON CO.,LTD.

Manufacturers of lenses for photographic, industrial, laboratory, video, and scientific applications.

Tokyo Main Office

Tamron Bldg., 17-11, 7-chome, Takinogawa, Kita-ku, Tokyo, Japan

Tel: (03) 916-0131 Telex: J23977 TAMRON Cable: "TAMRONTAISEI TOKYO"

58023000U Printed in Japan

英