

CANON INC.

9-9, Ginza 5-chome, Chuo-ku, Tokyo 104, Japan

CANON U.S.A., INC.

64-10 Queens Blvd., Woodside, N.Y. 11377, U.S.A.

CANON AMSTERDAM N.V.

Gebouw 70, Schiphol Oost, Holland

CANON LATIN AMERICA, INC.

Apartado 7022, Panama 5, Panama

PUB. NO. 5267V

1069D3.6

PRINTED IN JAPAN

Canon 

PELLIX

INSTRUCTIONS



English Edition

We are highly gratified that you have selected the Canon PELLIX QL—a wise choice that promises you many delightful years of photographic experiences.

Canon is recognized the world over as the foremost pioneer in the development of photographic equipment of the highest quality and performance.

Whether it is for the home, laboratory, or traveling, make the most of your opportunities!

Before Using . . .

It is important for you to thoroughly know and to get accustomed to handling the Canon PELLIX QL. Please read this instruction booklet carefully, and master the manipulations of the various parts completely. If you are thoroughly versed in the correct handling of the camera, you can get the maximum performance out of the Canon PELLIX QL to your greatest satisfaction.

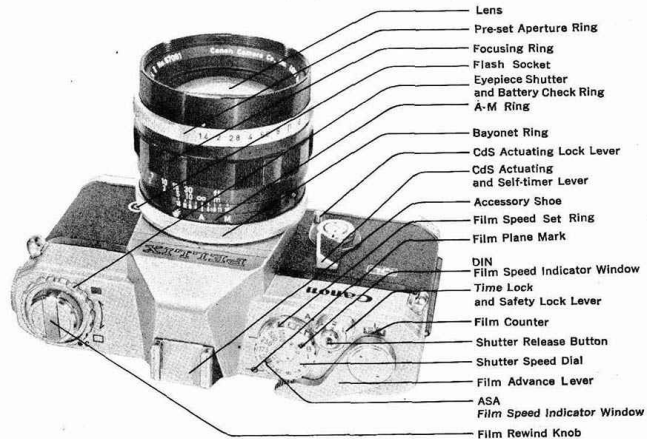

Technical Data

Type: 35mm single-lens reflex camera.
Viewfinder: Eye-level system using pentagonal prism. Waist-Level Viewer 2 can be attached.
Focusing Glass: Highly efficient in resolving power, using Fresnel lens and built-in prism screen rangefinder.
Mirror: The Canon Pellicle Mirror, a half transparent mirror.
Standard Lens: FL 50mm F1.8, FL 50mm F1.4, FL 55mm F1.2, FLP 38mm F2.8.
Aperture: Fully automatic pre-set aperture built-in. Pre-set release possible.
Shutter: 1/1000-1 sec. and B(T) X single pivot dial focal plane shutter.
Exposure Meter: Built-in. Zero-method CdS cell coupled to shutter dial and aperture setting. TTLM system. EV 0.5 (with ASA 100 film, F 1.2 at 1 sec.)-EV 18 (F 16 at 1/1000 sec.) one stage system. ASA 25-2000. Powered by one 1.3 V M20 (# 625) mercury battery.
Photometry: Exposure meter functions with the CdS actuating lever. Continuous photometry is possible with the CdS actuating lock lever. Battery checker built in.

Measuring of Ultra-Low Illumination: EV 1.5 1/2 sec. - EV -4.5 30 sec. at F 1.2 can be measured with the attachment of the Canon Booster (auxiliary meter for extremely dim lighting).
Flash Synchronization: Synchronizing possible for FP and X contacts and FP class, M class, MF class and speedlight.
Self-timer: Built-in.
Film Rewinding: Done by button and crank.
Film Advance Lever: Single operation 174° winding lever, possible to wind with several short strokes.
Film Loading: Back cover opening and closing, using only cartridge. The Canon-developed QL mechanism makes possible simple and quick loading of film.
Interchangeable Lenses: Automatic pre-set aperture type FL series lens system.
Film Counter: Self-resetting type.
Size: 144 x 91 x 43 mm (5 $\frac{5}{8}$ " x 3 $\frac{3}{8}$ " x 1 $\frac{3}{4}$ ").
Weight: 755 grams (1 lb. 10 $\frac{5}{8}$ oz.)—body only.

Subject to alterations.

Contents

Mercury Battery Loading	8
Film Winding	10
Shutter and Aperture Adjustment.....	12
How to Use Built-in Exposure Meter	16
Exposure Setting 1—Shutter Speed Priority Method.....	18
Exposure Setting 2—F Stop Priority Method	19
Coupling Range of Built-in Exposure Meter.....	20
Focusing	21
Holding the Camera.....	23
Film Loading	25
Film Rewinding	28
Photography Using Self-timer and Eyepiece Shutter	29
Flash Synchronization.....	30
Uses of Lenses	31
Double Exposure	36
Filters	37
Proper Care of the Canon PELLIX QL.....	38
Interchangeable Lenses and Accessories	40
Canon Booster	43

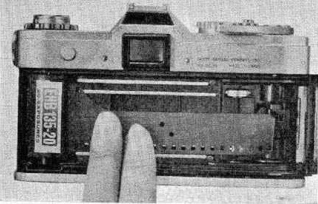

1 Load the film.

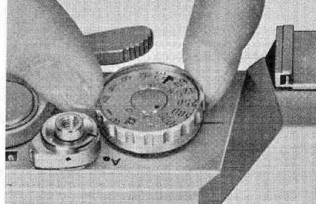

2 Set the film speed.

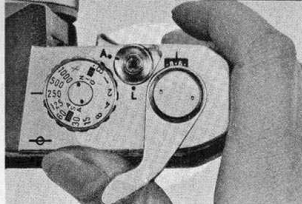

3 Wind the film advance lever.



4 Remove the lens cap.

5 Look through the viewfinder.

6 Focus and compose the picture.

7 Determine the exposure with built-in meter.

8 Press the shutter release button.

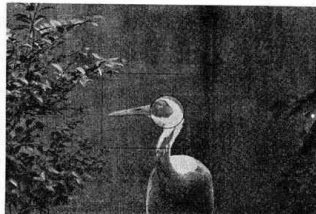

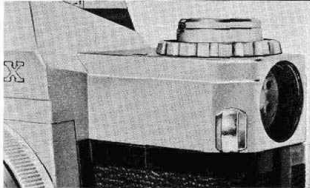

Mercury Battery Loading

Load the mercury battery into the battery compartment. The mercury battery powers the built-in CdS exposure meter, and the meter will not function unless the battery is in position.

- 1 Press the finger against the battery cover and turn to the left to remove.
- 2 Face the central contact of the mercury battery inwards and insert, then screw the cover back in.

◆ Before insertion, clean mercury battery thoroughly with a dry cloth. Perspiration or finger marks may cause corrosion and may prove particularly harmful to center of contact. Unclean battery may also damage the contact point



Central Contact

of the camera.

◆ For mercury battery, National H-D is used—equivalent to Mallory RM-625R, Eveready E625N, Burgess Hg-625R. Life of the battery in continuous use is approximately one year.

◆ When inserting, do not confuse the ⊕ ⊖. Not only will the meter fail to function in case of reverse insertion, but the cover cannot be screwed in properly.

◆ When not in use for a long period, remove the battery and keep in a dry place.



Battery Check

Check the mercury battery after loading it. Especially when loading a new battery, be sure to check the voltage.

- 1 Set the film speed graduation of the shutter dial at ASA 100 and set "X" at the index mark. Lift up the outer sensitivity ring of the shutter dial and turn. See page 16.
 - ◆ An accurate check cannot be made if settings other than those mentioned above are used.
- 2 Turn the check ring on the outer side of the film rewind knob and set "C" at the index mark.

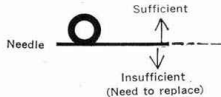

3 If the meter needle inside the viewfinder swings up to or over the 0 index, it means there is sufficient voltage. If the needle stays below the edge of the 0 index, voltage is insufficient and the battery must be replaced.

◆ In the Canon PELLIX QL, the electric current flows only when the CdS actuating lever is pressed.

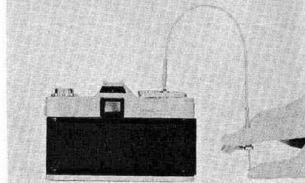
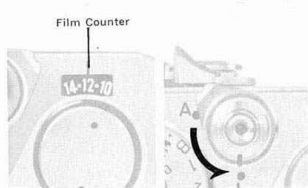
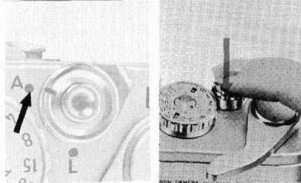
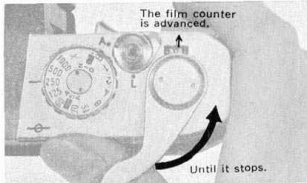

Film Winding

1 The turning of the film advance lever cocks the shutter, film winding and aperture charging in one motion.

2 When the shutter button is pressed, the diaphragm simultaneously closes down to the pre-selected F stop and the shutter operates.

Immediately after the shutter operation, the advance lever is again in ready position.

- ◆ Be sure that the safety lock lever is set at "A".

- ◆ The winding may be done by moving the lever with several short strokes.

- ◆ After loading the film, make another wind, since there is the possibility of the very first winding not catching.

- ◆ Unless the winding is completed, the shutter will not be actuated, even though the shutter button is pressed. In such a case, check the winding once more.

Film Counter

Each winding of film will advance the number of the film counter, indicating the number of pictures taken. When the back cover is opened, the indicator automatically returns to starting position "S".

Safety Device for Shutter

When the safety lock lever around the shutter button is turned to "L" position, the shutter is locked and will not move. This device may be used when the camera is carried in a wound condition.

Attaching the Cable Release

A cable release can be attached to the shutter button. Even if the safety lock lever is at "L" position, the shutter will operate by using the release.

When using the cable release, be sure to close the eyepiece shutter before shooting. Refer to instructions on page 29.

Make reverse turn when it stops at "X".

Make reverse turn when it stops at "B".

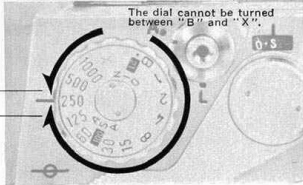

Shutter and Aperture Adjustment

The shutter and aperture adjust the exposure, with the shutter adjusting the exposure time and the aperture adjusting the amount of light. The Canon PELLIX QL uses the zero-method coupled meter, and it is very simple to get the proper exposure.

Shutter Speed Dial

By revolving the dial, it is possible to adjust the speed by turning it to the necessary index number. The index on the dial shows the denominators of 1/1000 sec., 1/15 sec., etc.

◆ The shutter speed dial does not revolve between the indexes "X" and "B".

◆ Set the index at the position where the click

stop catches.

◆ "B" means bulb exposure. The shutter, which remains open during the pressing of the shutter button, is employed when making exposures of more than one second.

In case of "B" index, adjust it to the white dot just below the "B" index.

◆ When it is necessary to make an exposure over an extended time, first set it at "B". Keep the shutter button pressed, turn the time lock lever to indicator "L". In this case, even if the finger is removed, the exposure continues. When the lever is returned to "A", the shutter closes.

◆ Time exposure is possible also by using the

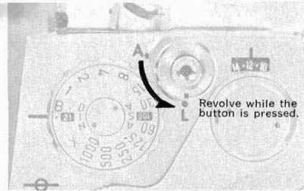

lock-attached cable release.

◆ The "X" index is used for synchronizing a speedlight. Although the shutter speed at "X" is 1/60 sec., actually it is equivalent to a very short exposure during the flash time of the speedlight.

Lens Aperture

The adjustment of the quantity of light and depth-of-field are made by turning the pre-set aperture ring to adjust the desired F stop to the index.

◆ As the numerical value of the F stop gets larger, the amount of light reaching the film becomes correspondingly less. For each F stop the light is reduced one-half. Accordingly, when



the aperture is increased by one index point, the exposure is doubled, and when it is increased by two index points the exposure is quadrupled.

◆ The aperture ring can also be set to intermediate values.

◆ Depending on the lens, there are instances where there is no relation to the lightness being halved between the maximum diameter of the aperture and the next aperture reading.

◆ The ratio between aperture and the amount of exposure, using F2 as the basis, is as follows:

Lens Aperture	1.2	1.4	1.8	2	2.8	3.5	4	5.6	8	11	16	22
Exposure Ratio	3	2	1.25	1	1/2	1/3	1/4	1/8	1/16	1/32	1/64	1/128

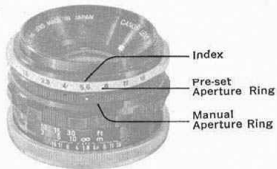
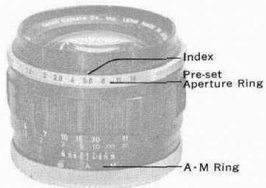

Pre-Set Aperture and Checking of Depth-of-Field

Lens with A-M Ring

1 Pre-Setting of Aperture: Set the A-M ring at "A". Then set the desired F stop on the pre-set aperture ring to the index. The diaphragm will close down to the pre-set F stop only for the instant that the shutter is released. Except for the instant that the shutter is released, the diaphragm will remain fully open.

2 Manually Operated Aperture: When the A-M ring is set at "M" the diaphragm closes down to the pre-set F stop. In this way the depth-of-field at the time of shutter release can be checked. When the A-M ring is reset at "A" the diaphragm again returns to maximum opening.

Lens with Manual Aperture Ring

1 Pre-setting of aperture: Set the desired F stop on the pre-set aperture ring to the index. Then set the index of the manual aperture ring to this pre-set F stop. The diaphragm will close down to the pre-set F stop only for the instant that the shutter is released.

2 Manually Operated Aperture: When the manual aperture ring is turned in the direction of closing down the diaphragm, after setting the desired F stop on the pre-set aperture ring to the index, the diaphragm will close down to the pre-set F stop and the depth-of-field can be checked. The manual aperture ring cannot be turned when set at maximum aperture opening.

◆ Refer to pages 34-35 concerning depth-of-field.

Relation Between the Pellicle Mirror, CdS, Diaphragm and Shutter

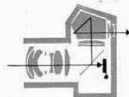

Determine the exposure by pressing the CdS actuating lever.

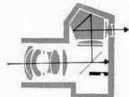

Release the CdS actuating lever.

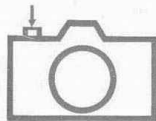

Press the shutter button.

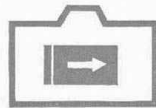

The shutter is clicked.

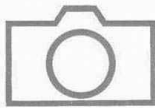

The diaphragm is fully opened.



The diaphragm begins to close.



Closed down to pre-set position.



The diaphragm begins to open.

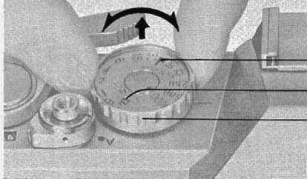

ASA Film Speed Indicator Window

DIN Film Speed Indicator Window

Lift up the outer film speed set ring and turn.

How to Use Built-in Exposure Meter

The exposure meter of the PELLIX QL, which is of the zero method type, is coupled to the shutter dial and aperture ring. The exact exposure is easily determined according to the brightness of the subject to be photographed. There are two ways of determining the exposure—either by first selecting the shutter speed or first selecting the F stop.

Film Speed Setting

Show the film speed of the film used in the small window. To do this, hold up and turn the film speed set ring around the shutter speed dial. If the film is ASA 100, for example, make correct setting by showing 100 in the ASA window.

◆ When ASA 25 appears in the small window, this is as far as it turns to the left. The right turn extremity reads ∙ (2000).

◆ The following film speeds may be used:

	(32)	(40)	(64)	(80)	(125)	(160)	(250)	(320)	(500)	(640)
ASA	25	∙	50	∙	100	∙	200	∙	400	∙
DIN	15	∙	18	∙	21	∙	24	∙	27	∙
	(16)	(17)	(19)	(20)	(22)	(23)	(25)	(26)	(28)	(29)
	(1000)	(1250)	(2000)							
	800	∙	1600	∙						
	30	∙	33	∙						
	(31)	(32)	(34)							

Figures in parentheses represent intermediate film speeds.

◆ The film speeds are shown either on the film box cover or on the explanatory sheet.

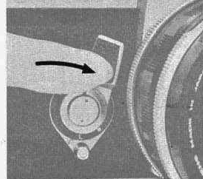

CdS Actuating Lever

The exposure meter can be set into measuring condition by turning the CdS actuating lever towards the lens.

The CdS actuating lever can be fixed by turning it towards the lens after setting the lock lever at "L" position. If the lock lever is returned to its original position (∙ index) the CdS actuating lever will also return to its original position.

◆ The shutter cannot be released while the CdS actuating lever is being turned or when it is locked with the lock lever.

How to Measure the Average Brightness

The exposure meter on the Canon PELLIX QL is of the spot reading type which accurately measures any special spot of the subject. Therefore, when measuring a subject with greatly differing dark and bright parts, take two measurements, one each of the dark and bright parts. Then obtain the average value and set the F stop or shutter speed accordingly.

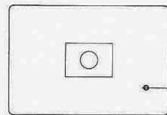
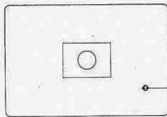
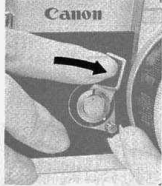

Exposure Setting 1—Shutter Speed Priority Method

- 1 Set the shutter at a desired speed.
- 2 Face the camera towards the photographic subject, look into the viewfinder, and press the CdS actuating lever fully.
- 3 Either keep pressing the lever or lock the lever and turn the aperture ring.
- 4 Set the meter needle at the 0 index within the viewfinder for correct exposure.

◆ Canon's TTLM system has been adopted in the PELLIX QL which provides the most accurate photometry. Under this system, the CdS photocell of the built-in meter is placed in the closest position to the film on the back side

of the pellicle mirror.

◆ The rectangular frame on the outside of the prism screen within the viewfinder is the same size as the light receiving area of the CdS photocell. Place the center of the photographic subject within this frame and measure the intensity of light. In this way the photographer can decide the best exposure for his photographic needs. The TTLM system makes possible the measuring of exposures in counter-light conditions.

◆ Measurement at "B" and "X" indexes of the shutter dial is not possible with the exposure meter because "B" is used for long exposures over one second and "X" is used for speedlight.

Exposure Setting 2 — F Stop Priority Method

- 1 Set the lens aperture at the desired F stop.
 - 2 Face the camera towards the photographic subject, look into the viewfinder, and press the CdS actuating lever.
 - 3 While pressing or locking the CdS actuating lever, turn the shutter dial.
 - 4 Set the meter needle at the 0 index within the viewfinder for correct exposure.
- ◆ Intermediate positions on the shutter speed dial cannot be used, but since any aperture may be utilized, the shutter speed should first be determined when strictly considering the

exposure. It is most practical to adjust the aperture according to this.

◆ During the use of the meter, there are instances of the movement of the needle becoming slack, owing to changes in the degree of light, but this is due to the characteristics of the CdS.

◆ When taking pictures against light, always use a lens hood.

◆ When the subject is too bright or too dark and is outside the coupling range of the built-in exposure meter, the meter needle will point to the top of the viewfinder and will indicate that proper exposure cannot be obtained. Refer to "Coupling Range of Built-in Exposure Meter" on the following page.

Coupling Range of Built-in Exposure Meter

The built-in exposure meter couples to the following range of F stops and shutter speeds with respective film speeds. When using the F 1.2 Lens and ASA 100 film, for example, the expo-

sure meter couples fully within the range of F 1.2 at 1 sec. (EV 0.5) and F 16 at 1/1000 sec. (EV 18).

Film Speed		Shutter Speed										
ASA DIN	25 15	1	1/2	1/4	1/8	1/15	1/30	1/60	1/125	1/250
ASA DIN	50 18	...	1	1/2	1/4	1/8	1/15	1/30	1/60	1/125	1/250	1/500
ASA DIN	100 21	1	1/2	1/4	1/8	1/15	1/30	1/60	1/125	1/250	1/500	1/1000
ASA DIN	200 24	1/2	1/4	1/8	1/15	1/30	1/60	1/125	1/250	1/500	1/1000	...
ASA DIN	400 27	1/4	1/8	1/15	1/30	1/60	1/125	1/250	1/500	1/1000
ASA DIN	800 30	1/8	1/15	1/30	1/60	1/125	1/250	1/500	1/1000
ASA DIN	1600 33	1/15	1/30	1/60	1/125	1/250	1/500	1/1000
ASA DIN	2000 34	1/30	1/60	1/125	1/250	1/500	1/1000
f/Stops	f/1-22	f/1-22	f/1-22	f/1-22	f/1-22	f/1-22	f/1-22	f/1-22	f/1-22	f/1-22	f/1-22	f/1-16

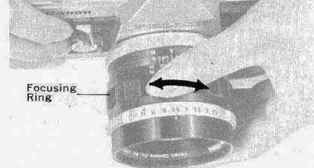

Focusing Ring

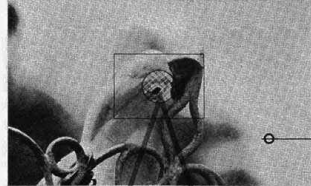

Focusing

While looking through the viewfinder, rotate the focusing ring.

It is out of focus when the image within the circle in the center of the viewfinder is unclear. It is in focus when the images coincide and the unclear images become clear.

◆ The center of the viewfinder (circular section) is the prism screen type rangefinder for focusing made up of microscopic prisms.



Out of focus



In focus

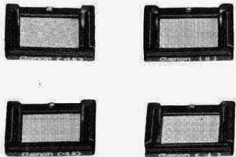

Holding the Camera

Holding the camera firmly is very important in order to take a clearly focused picture. Hold the camera in either vertical or horizontal position, as shown in the photographs. Look through the viewfinder and adjust the focus while determining the composition. Then, gently press the shutter button. At this time, it is important to consider the following points:

- 1 Hold the camera with both hands as firmly as possible.
- 2 Stabilize the camera by pressing it against the cheek or forehead.

Composition and Viewfinder

The exact picture image to be photographed on the film can be seen on the ground glass without any parallax. It is possible to determine the composition exactly according to the viewfinder.

◆ Waist-Level Viewer 2 can be attached to the eyepiece for copying, enlarging and microphotography. In this case, the image is reversed left and right.

◆ Eyesight adjustment lenses are available as optional attachment. When an eyesight adjustment lens is attached to the eyepiece, those who are far-sighted or near-sighted can take pictures without glasses. Four different diopters of +1.5, 0, -2.5, and -4 are available.

3 When the camera is in a horizontal position, both elbows should be firmly pressed against the body, and at least one elbow should be resting against the body when in a vertical position.

- ◆ Rough pressing of the shutter button is a cause of blur.
- ◆ It is advisable to use the tripod and cable release. Particularly recommended when using a slow shutter speed below 1/30 sec.

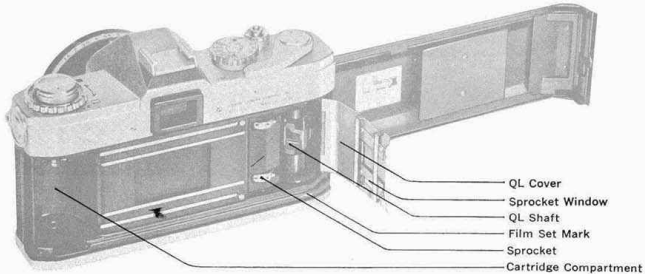

Direction in which film is placed
(emulsified surface facing the back of the lens)

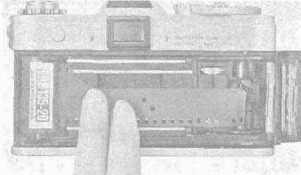
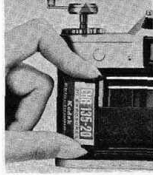
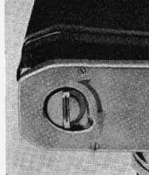
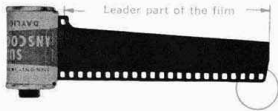

Film Loading

Canon PELLIX QL accepts any standard 35mm film in cartridge for daylight loading.

When loading a new film, avoid direct sunlight.

◆ When repacking a long-wound film for darkroom loading into the ordinary cartridge, trim the end of the leader part in between the perforations.

1 Open the back cover.

Raise the back cover lock, make a half turn to the left, and the cover will rise.

Open the back cover fully. When the back cover is opened, the QL cover also opens simultaneously and is ready for loading the film.

◆ The QL cover automatically opens and closes together with the opening and closing of the

back cover. Do not touch the QL cover.

2 Insert cartridge.

Raise the rewinding knob all the way. When the cartridge has been inserted, push the knob back to its former position again. Push the fork into the axis of the cartridge. In case the knob does not fully return, it can be easily put into proper position by turning it slightly to the left or right.

3 Set film tip to the red mark.

Face the cartridge as shown in the picture and hold the film down with the left hand so that it does not rise.

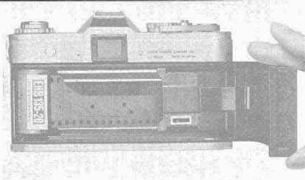

4 When the back cover is half-closed, the QL cover presses down on the film. Check through the sprocket window whether the film has been engaged correctly onto the gear.

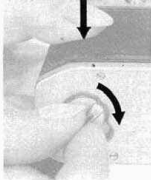

5 Close the back cover. Press down to prevent the cover from rising, then turn the back cover lock clockwise to close.

Fold down the rewinding crank.

◆ If the film is sagging, the cartridge will rise and the back cover will not close.

6 Make three blank shots. Leave the lens cap on and advance the film three times, each time releasing the shutter. The film counter will advance from the "S" mark to "0". With one more advance, the camera will be ready for the first shot.

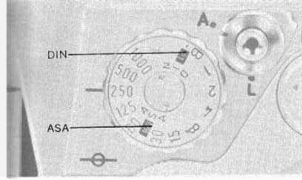

Setting the Film Speed

When loading the film, be sure to set the film speed in the window of the shutter dial. Refer to page 16 for setting the film speed.

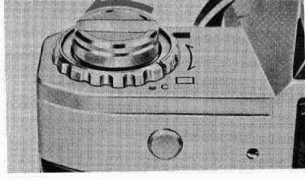

Checking Correct Film Loading

The film is properly loaded and transported if the rewind knob rotates when the film advance lever is wound. If the rewind knob does not rotate, it means the film was not loaded properly. If such is the case, take out the film, as illustrated on page 28, and reload the film.

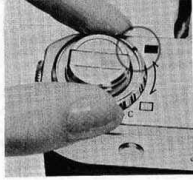
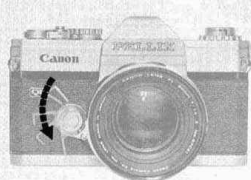
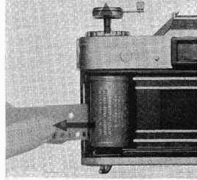
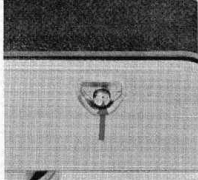

Film Rewinding

Since no further winding is possible when the film has reached the end, rewind the film immediately into the cartridge. As the exposed film is naked within the camera, the entire roll will be exposed and ruined if the cover is opened before rewinding.

1 Press in the rewinding button.

2 Rewind with crank.

Raise the rewind knob, turn the crank in the direction of the arrow, and return the film into the cartridge. When the rewinding button stops revolving and rewinding resistance becomes light, immediately stop rewinding.

3 Open the back cover.

4 Remove the cartridge.

Raise the rewind knob completely and remove the cartridge.

◆ Once the rewinding button has been pressed, the finger may be removed. The button will return automatically when the lever is wound.

◆ If winding is continued after the film is at its end, the film will come loose from the cartridge spool or tear and rewinding will become impossible. If this happens, open the back cover in a completely dark room.

Photography Using Self-timer and Eyepiece Shutter

Wind the shutter and close the eyepiece shutter. Turn the self-timer lever in the direction of the arrow and press the shutter button. The shutter will be actuated approximately 10 seconds later.

- ◆ Be sure to wind the self-timer completely.
- ◆ Be sure to wind the shutter. If this is neglected and only the self-timer is wound and the shutter button pressed, the self-timer will act but the shutter will not be actuated.
- ◆ The self-timer lever can be used as a CdS actuating lever as soon as it returns to its original position. When taking shots with the

eye off the eyepiece, such as when using the self-timer or cable release, always be sure to close the eyepiece shutter.

Eyepiece Shutter

Since the Canon PELLIX QL incorporates the mirror, the light rays may cause ghosts on the film plane if the viewfinder eyepiece receives strong light.

- ◆ For closing the eyepiece shutter, turn the eyepiece shutter ring to the left and set the index mark to ■.

Insert the flash unit into the accessory shoe.



Flash Synchronization

By connecting the cord of the flash unit or speedlight to the flash socket, it is possible to synchronize the following shutter speeds.

When taking pictures with flash, light volume adjustment is required because the Canon PELLIX QL uses a stationary mirror. Obtain F stop by guide number and further open aperture by one-half.

◆ A lens hood is necessary when taking flash pictures.

Type		Synchronized Shutter Speeds ¹⁾
Flash Bulb	FP class (#6, Press 26)	1/60 or faster 1/15 or slower
	M class (M3, #5, Press 25)	1/15 or slower
	MF class (AG-1, AG-3, M2, Flashcube)	1/15 or slower
Electronic Flash Unit	Speedlite	"X" setting (equiv. to 1/60 sec.) 1/30 or slower

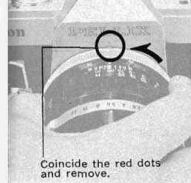

Uses of Lenses

Changing Lenses

In removing the lens from the camera, after turning the bayonet ring of the lens to the left, take out the lens.

In mounting the lens, match the red dot of the lens to the red dot on the camera mount. Turn the bayonet ring to the right and fasten.

◆ When mounting, turn the bayonet ring of the lens sufficiently to the left and coincide the red dot and guide pin of the lens.

◆ Do not change your lens in a strong light. When changing your lenses have the replacement lens at hand. Then quickly change the lenses in the shade... or use your shadow as a shield from direct light.

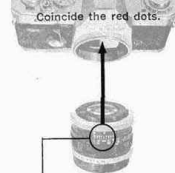

Coincide the red dot and guide pin.



Pre-set Aperture Lever

◆ There is a pre-set aperture lever at the back end of the lens which opens and closes the aperture. When the lens is removed, be sure to always put on the dust cap so as to protect the aperture lever.

◆ If interchangeable lenses are changed while the CdS actuating lever is in locked position, the pre-set aperture lever cannot be connected to the coupling part on the camera body and the pre-set aperture will not function. Be sure to unlock the CdS actuating lever when changing interchangeable lenses.

◆ Do not touch the pellicle mirror or the coupling section of the aperture. When not in use for a long time, protect the pellicle mirror by putting on the flange cap.



Distance Scale

Indicator
(central
orange line)

Infrared Index "R"

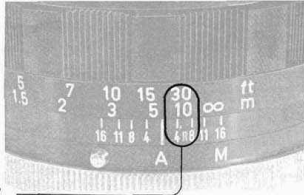

Infrared Index "R"

For infrared photography, correction of the distance scale is necessary because the focal position deviates a little from ordinary photography. Make ordinary focusing first, then adjust that distance scale to the infrared mark "R". For instance, if the distance reads 10m after focusing, merely shift the 10 scale to "R" position.

◆ The position of "R" is scaled according to the use of the standard of a film with the highest sensitivity of a wave length of about $800m\mu$ and infrared filter (for example, KODAK IR 135

film and WRATTEN 87 filter).

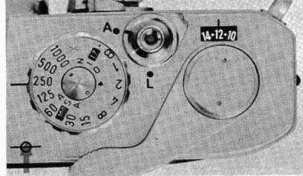

Film Plane Mark

The lens distance index is scaled by measuring the distance from the film position. Thus, in case the focusing is done by actual measurement, measure from the film plane mark and transfer this distance to the lens distance index.

◆ Traces of water bubbles cannot be entirely removed from glass used for high quality lenses because of the manufacturing process. Lens bubbles will not at all affect the sharpness of the picture.

Distance Scale

The distance scale indicates the distance between the focused subject and the film plane. The scale is necessary for checking the depth-of-field, for infrared photography and flash photography.

◆ The correct position of the scale, where the distance is a one-digit figure, is in the middle of the figure; if it is a two-digit figure, it is between the two figures; and if it is a three-digit figure, it is in the middle of the central figure.

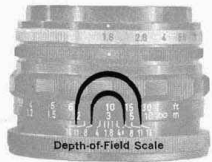

Depth-of-field Scale

The depth-of-field scale indicates the range of subjects which will be in sharp focus on the film. This range will vary with the following factors: The depth-of-field will be deeper the smaller the lens aperture, the further the distance of the subject, and/or the shorter the lens focal length. The depth-of-field will be shallower the larger the lens aperture, the nearer the distance of the subject, and/or the longer the lens focal length.

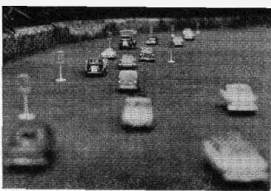

F 8 50 mm Depth-of-field 2.3 m - 4.3 m
Focused at 3 m



For example, if the lens is 50mm and the subject has been focused at a distance of 3m, with an F8 aperture, the depth-of-field would be from approximately 2.3m to 4.3m as indicated on both sides of the distance index.

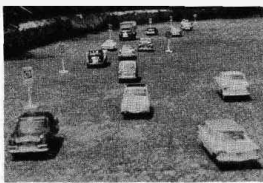

F 16 50 mm Depth-of-field 1.9 m - 7.6 m
Focused at 3 m



Similarly, if the aperture is F16, the picture will be sharp from about 1.9m to 7.6m. This range will vary with the F stop selected.

◆ FL series of the Canon lenses have a feature which lets you see the actual sharpness through the viewfinder by turning the manual aperture ring.

Lens Mount (FL and R Series Lenses)

As the lens mount for the Canon PELLIX QL is the same as for Canon PELLIX, FT QL, FX, and FP, it is possible to use all FL series lenses except the 19mm F3.5 lens. The 19mm F3.5 lens cannot be attached because the PELLIX QL uses stationary type pellicle mirror. Use FL 19mm F3.5R for exclusive use with the Canon PELLIX QL instead.

◆ It is possible to attach and use all the R series lenses for CANONFLEX use. However, as the automatic aperture mechanism differs, pictures must be taken with the manual aperture.

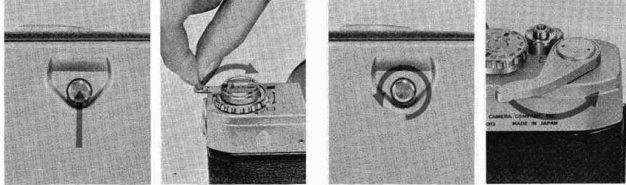

Double Exposure

Under ordinary usage, there is no danger of double exposure. However, double exposure can be made by the following steps:

- 1** When the first exposure has been made, press the rewinding button.
- 2** Rewind the film with the rewinding crank by watching the mark on the rewinding button carefully.
- 3** Stop rewinding when the mark has made 3/4 turning, i. e., 270°. Be sure not to exceed one turn of the rewinding button.

4 Next, wind the film advance lever while lightly holding the rewinding crank. When resistance is felt on the rewinding crank, stop the winding.

5 Wind the film advance lever once more. By repeating the above process, it is possible to make any number of exposures on the same film plane. The film counter will, however, continue to advance with each exposure.

Various types of 58mm (for FL 50mm F3.5, 50mm, F1.4, 55mm F1.2) and 48mm (for FL 50mm F1.8) screw-in type filters are available for special effects in both color and black and white photography. The exposure meter for the Canon PELLIX QL is of the TTLM system and so there is absolutely no necessity for compensation of exposure factor.

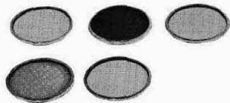

Filters

UV
for color and black and white

Y1 }
Y3 }
O1 } for black and white
R1 }
G1 }

ND 4 } for color and
ND 8 } black and white

Skylight }
CCA 4 }
CCA 8 } for color
CCA (12 equiv.) }
CCB 4 }
CCB 8 }
CCB (12 equiv.) }

- Absorbs only ultra-violet rays. Especially effective at seaside, high mountains where there is much ultra-violet rays. Recommended for use in color photography.
- Increases contrast of black and white film. Enhances clouds, darkening the blue sky. Brightens red and yellow.
- Darkens blue, increases yellow and red volume perceptibly. Good for contrasts in distant landscapes.
- Makes strong contrasts. Renders day almost into night. May also be used with infrared film.
- Prevents red from turning radically into white. Lightens sky and face appropriately, and reflects the lightness of fresh greenery.
- ND 4 reduces light values by 1/4, ND 8 by 1/8. No effects on the reproduction of colors of color film.
- Acts to harmonize the blue sky and shade.
- For use with daylight type film under the cloud.
- For use with universal type (color negative) film under the cloud or tungsten type film under the morning sun or sunset.
- For use with tungsten type film under sunlight.
- For use with daylight type film under the morning sun or sunset.
- For use with daylight type film and clear flash bulb.
- For use with daylight type film under tungsten light.

Proper Care of the Canon PELLIX QL

Storage of Camera

Moisture and dust are harmful to your camera. It should be taken out into the fresh air from time to time.

If your camera is to be stored for a long time, it should be removed from its case. Silica gel or another drying agent should be placed alongside it.

Cleaning of the Camera

When you use your camera on a rainy day, or at the beach, moisture and salt air adhere to it, which can result in stains, rust, and corro-

sion. Use a soft brush to rid the dust and a soft dry cloth for wiping.

Cleaning the Lens

Use a blower with a rubber ball to blow away dust on the lens or brush lightly with a brush. Do not touch the lens. If you should inadvertently get a fingerprint on your lens, follow this procedure: use a little pure alcohol, or ether, if available on special lens cleaning tissue. Then wrap the tissue around a wooden matchstick and wipe the lens in a circular motion . . . lightly and systematically.

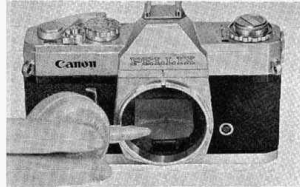

◆ Never touch the pellicle mirror. If dust should accumulate on it, blow it away with a blower.

◆ In extremely cold areas, expose the camera to the outer air only when in use. Put it back into its case immediately after use. When using in cold climates, expose the camera gradually to the outer air to prevent the lens from clouding.

◆ In hot climates, do not leave the camera *inside closed automobiles during the daytime* or in direct sunlight. It is not good for the CdS cell.

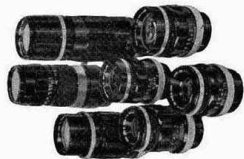

Canon Zoom Lens FL 85-300mm F 5



Canon Lens FLP 38mm F 2.8

Interchangeable Lenses and Accessories

A wide range of interchangeable lenses from 19mm to 1000mm and various accessories are available to further enhance your PELLIX QL.

Canon Interchangeable Lenses

FL 19mm	F 3.5R	FL 135mm	F 3.5
FL 28mm	F 3.5	FL 135mm	F 2.5
FL 35mm	F 3.5	FL 200mm	F 4.5
FL 35mm	F 2.5	FL 200mm	F 3.5
FLP 38mm	F 2.8	R 300mm	F 4
FL 50mm	F 3.5	R 400mm	F 4.5
FL 50mm	F 1.8	R 600mm	F 5.6
FL 50mm	F 1.4	R 800mm	F 8
FL 55mm	F 1.2	R 1000mm	F 11
FL 85mm	F 1.8	FL-F 300mm	F 5.6
FL 100mm	F 3.5	FL-F 500mm	F 5.6

Canon Zoom Lenses

The Canon zoom lenses are the high performance lenses with fully automatic pre-set type diaphragm designed specially for the owners of the PELLIX QL.

FL 55-135mm	F 3.5
FL 100-200mm	F 5.6
FL 85-300mm	F 5

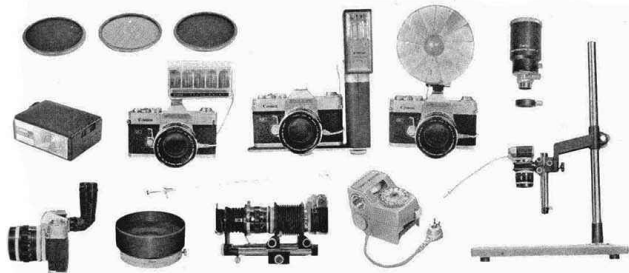

Accessories

- Filters (48 and 58mm screw-in type)
- Lens Hood
- Flash Quint
- Canon Speedlite 102, 200
- Flash V-3
- Bellows R
- Canon Release
- Waist-Level Viewer 2
- Bellows FL
- Photomicro Unit F
- Canon Booster
- Copy Stand 3F
- Handy Stand F
- 58mm Close-up Lens 240, 450, 1800
- Camera Holder R4-2

Viewfinder Eyepiece

Eyesight Adjustment
Attachment Groove

Mercury Battery
Compartment

Back Cover

Back Cover Opening Key

Tripod Socket

Rewinding Button

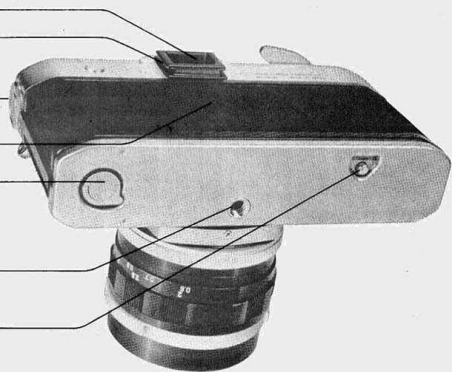

Canon Booster

A separately available Canon Booster is an auxiliary meter that is attached to the PELLIX QL and FT QL for measuring the subjects under dim lighting conditions.

Technical Data

Light Measuring Range: Using ASA 100 film ;
EV 1.5 1/2 sec. - EV - 4.5 30 sec. at F 1.2.

Measuring Method: Zero-method direct reading
type.

Photocell: Utilizes CdS cell of the camera.

Exposure Time Dial: In the case of PELLIX QL ;
60, 30, 15, 8, 4, 2, 1, 1/2, 1/4, 1/8, 1/15, 1/30 sec.

Power Sources: For operating meter, use two
1.3V M20 (#625) mercury batteries.

For illumination of meter indicator window,
use one 1.3V M20 mercury battery (use the
battery removed from the camera).

Battery Check: Can be checked by the switch.

Size: 65 x 54 x 39mm (2 1/2" x 2 1/8" x 1 1/2").

Weight: 180 grams (6 3/8 oz.).

